

ETA-10/0189

# WALCO® V 80

Wandverbinder

Kragenschraube 16x60 mm

Art. - Nr. K103



WALCO V 80



## 1. Bohren

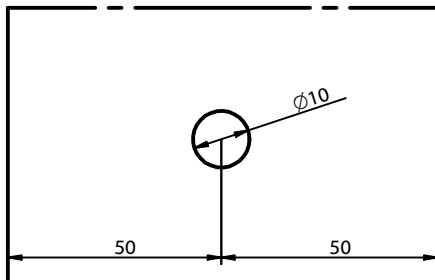

## 2. Eindrehen der Kragenschraube

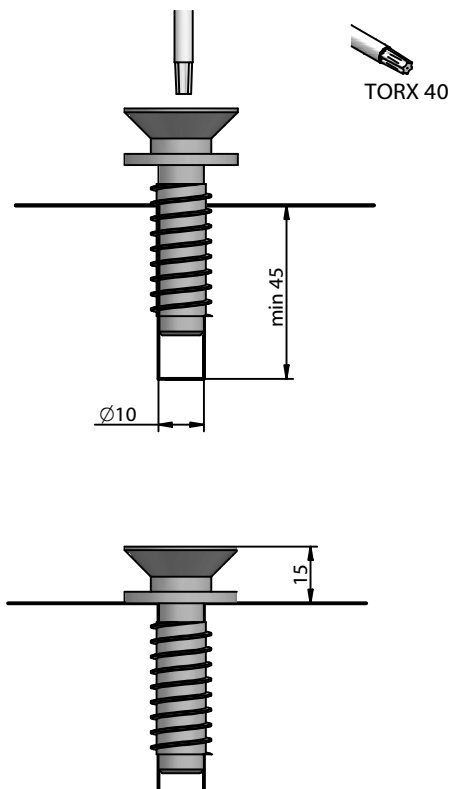

**Hinweis:** Die Höhe kann durch unterlegen einer weiteren Unterlegscheibe verändert werden.

## 1. Ausfräsung herstellen

Mindest- Ausfräsmaße

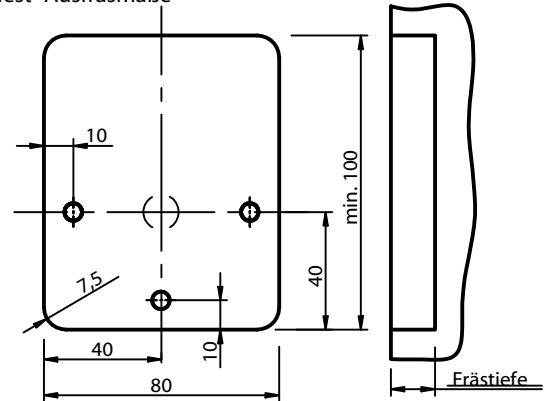

Halteschraube	Einfrästiefe
Kragenschraube	15 mm fugenlose stramme Montage
Einstellbare Halteschraube	13 mm leichtes Einhängen (2 mm Fuge)
Gefederte Halteschraube	13- 17 mm

## 2. Schraubenposition mit Anreißschablone markieren

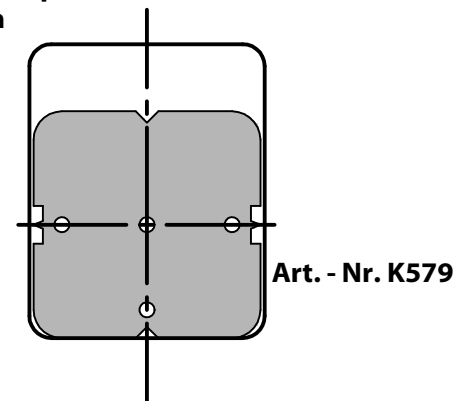

## 3. Verbinder montieren

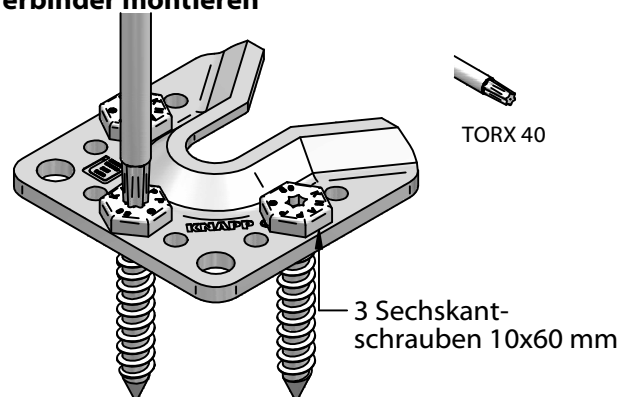

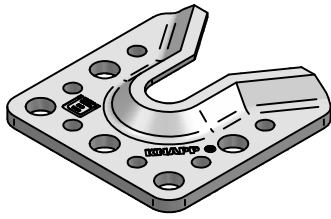

ETA-10/0189

# Montageanleitung WALCO® V 80

Wandverbinder

**Gefederte Halteschraube M16**  
**Art. - Nr. K107**



**Einstellbare Halteschraube M16**  
**Art. - Nr. K105**



**1. Bohren**

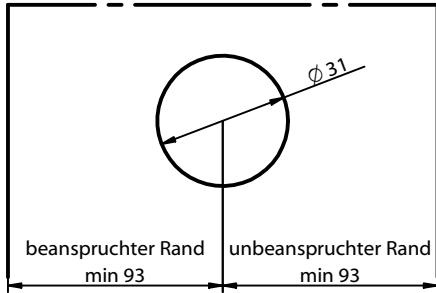

**2. Eindrehen der Einschraubmutter mit Eindrehwerkzeug**

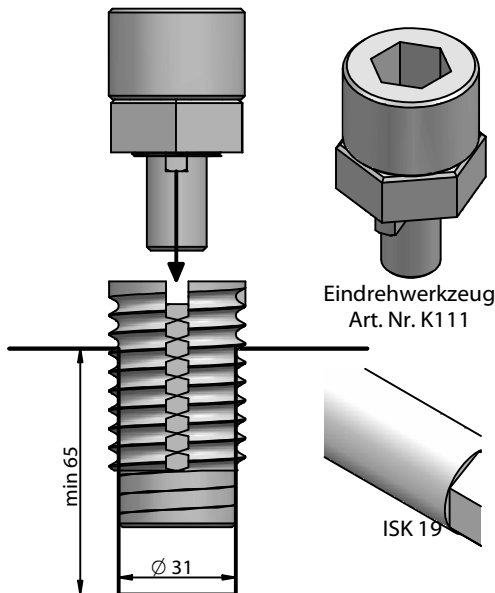

**3. Halteschraube M12 eindrehen und auf Höhe justieren**

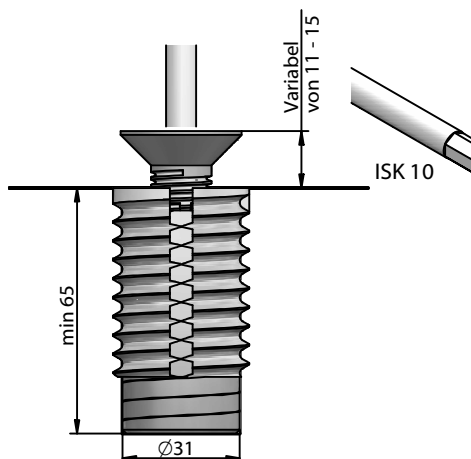

**1. Stufenbohrung erstellen**

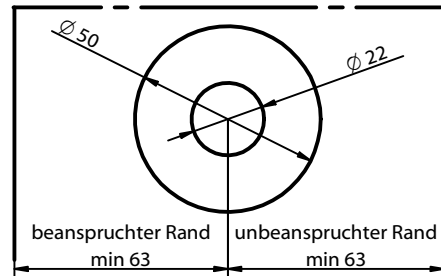

**2. Eindrehen der Einschraubmutter**

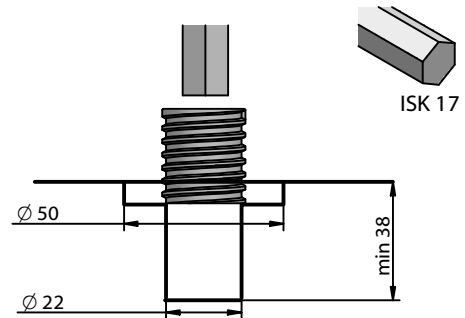

**3. Eindrehen der Halteschraube incl. Mutter M16**

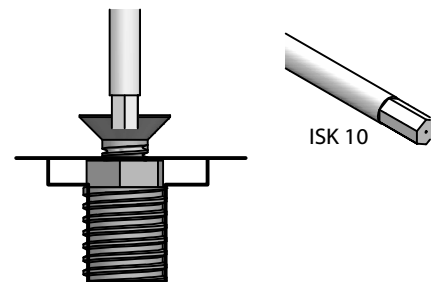

**4. Höhe justieren und Schraube mit Mutter fixieren**

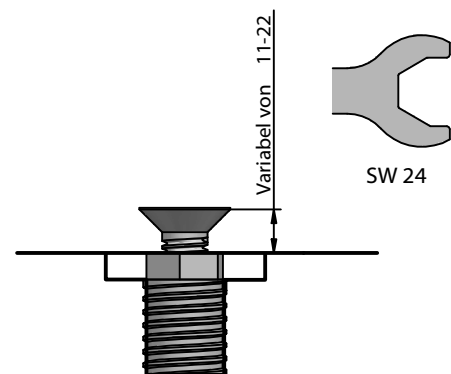

Diese Zeichnung ist Eigentum der Knapppart GmbH

© Knapppart GmbH. Alle Maße in mm - Irrtümer, Druckfehler und Änderungen vorbehalten / all measures in mm - Errors excepted. VERSION 12.08.2013

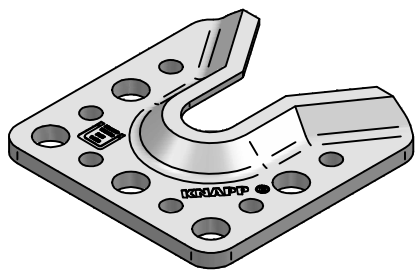

# Montageanleitung WALCO® V 80 VK D16

Wandverbinder

## Verschraubter Kragenbolzen Art. - Nr. K109



### 1. Bohren

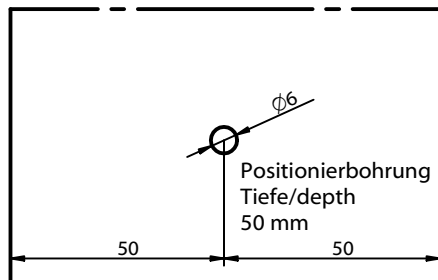

### 2. Eindrehen der Schraube in den Kragenbolzen

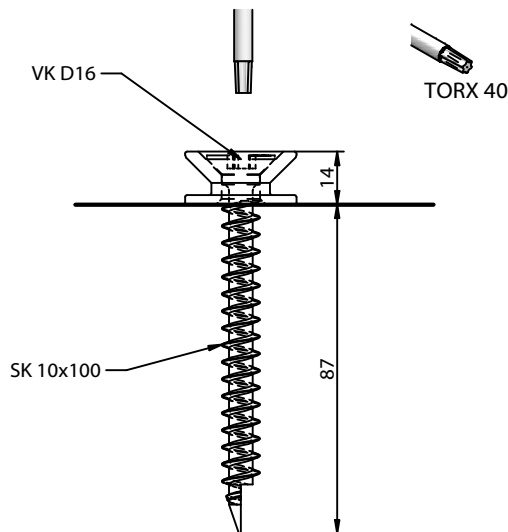

**Hinweis:** Höhe kann durch unterlegen einer weiteren Unterlegscheibe verändert werden!  
Die Vollgewindeschraube kann auch mit einem  $\phi 7$  mm Bohrer vorgebohrt werden!

## WALCO V 80



### 1. Ausfräsung herstellen

Mindest- Ausfräsmaße:

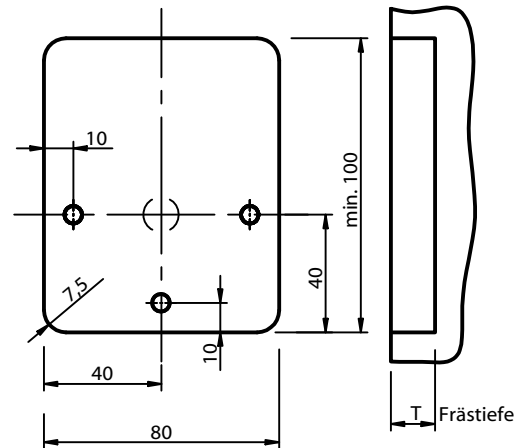

Frästiefe:  
15 mm für fugenlose stramme Montage  
13 mm für leichtes Einhängen (mit 2 mm Fuge)

### 2. Schraubenposition mit Anreißschablone markieren

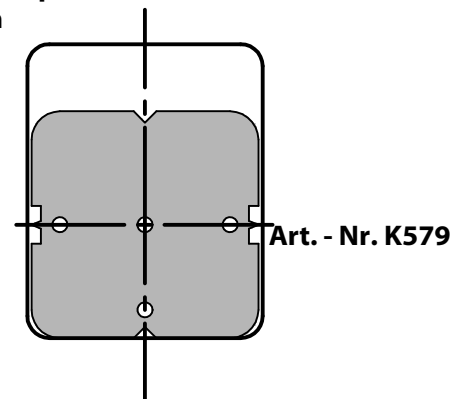

### 3. Verbinder montieren

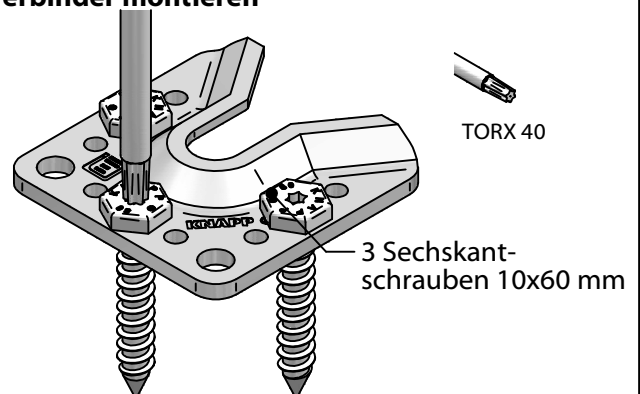



# WALCO® V 80

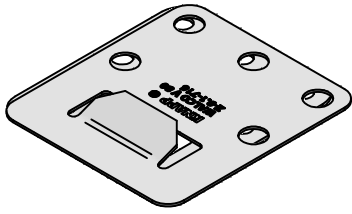

WALCO V Sperrklappe  
Art. - Nr. K113

WALCO V 80

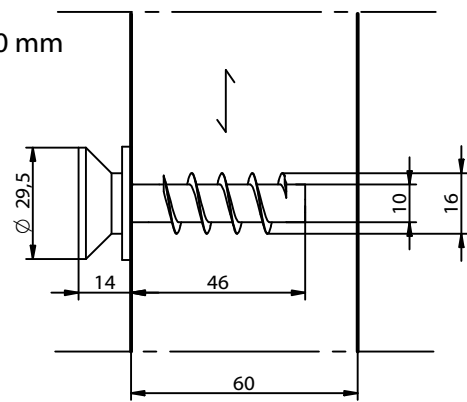
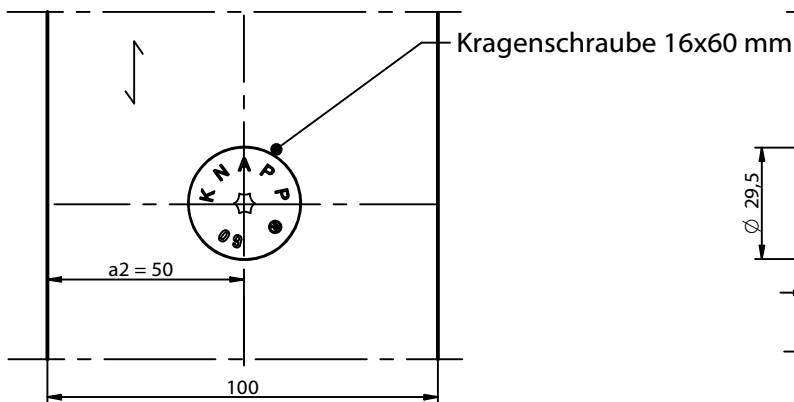
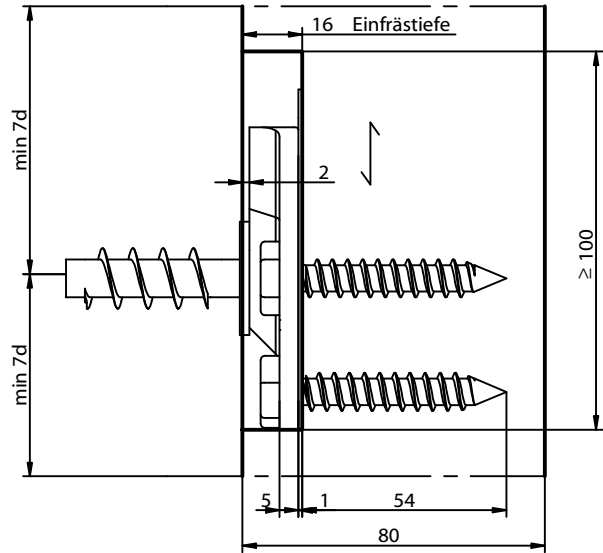
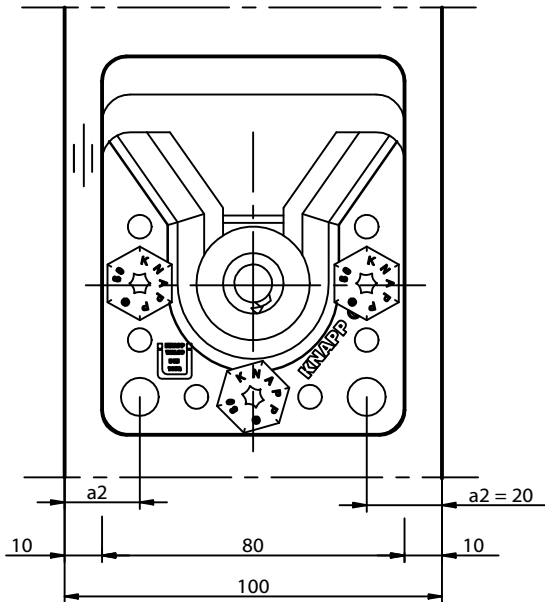

### 1. Positionieren

### 2. Einführen

### 3. Verriegeln

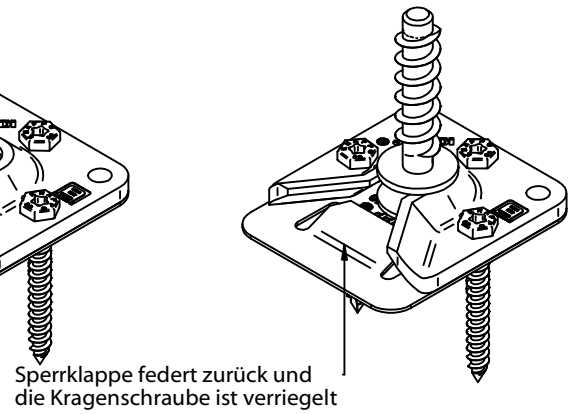
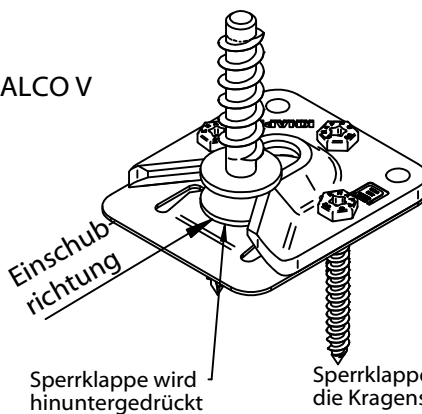
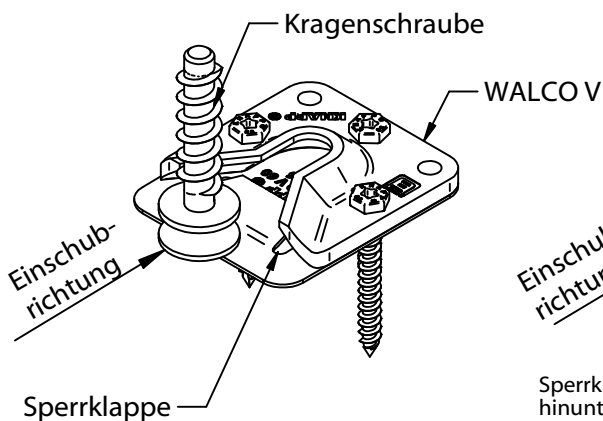

Diese Zeichnung ist Eigentum der Knapp GmbH

© Knapp GmbH. Alle Maße in mm - Irrtümer, Druckfehler und Änderungen vorbehalten / all measures in mm - Errors excepted. VERSION 12.08.2013



ETA-10/0189

# WALCO® V 80

Wall connector

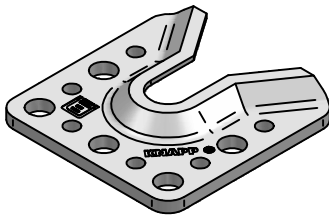

Collar screw 16x60 mm  
Art. - No. K103

WALCO V 80

## 1. Drilling

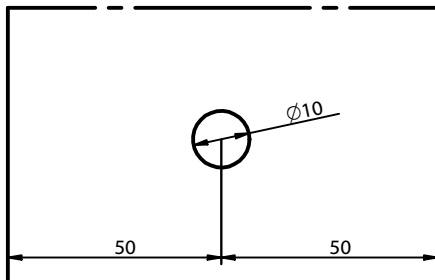

## 2. Screwing collar screw

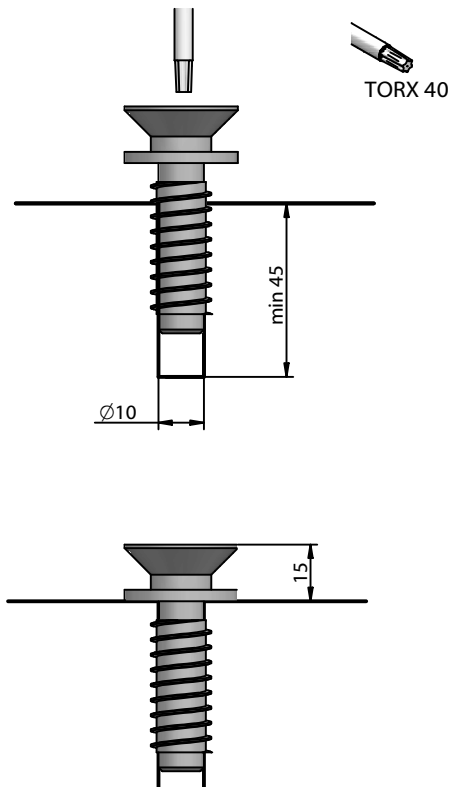

**Tip:** If the collar screw requires a higher height, one additional washer can be laid under the collar screw washer.

## 1. Machined edge

Minimum milled dimension:

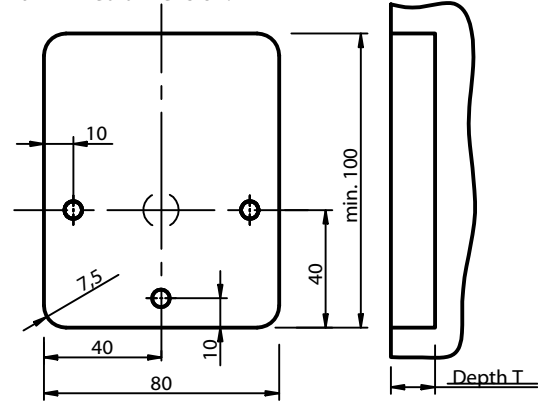

Holding screw	Depth T
Collar Screw	15 mm without joints => tight fitting
Retaining holding screw	13 - 24 mm
Retaining spring holding screw	13- 17 mm

## 2. Marking Connector position with scribing jig

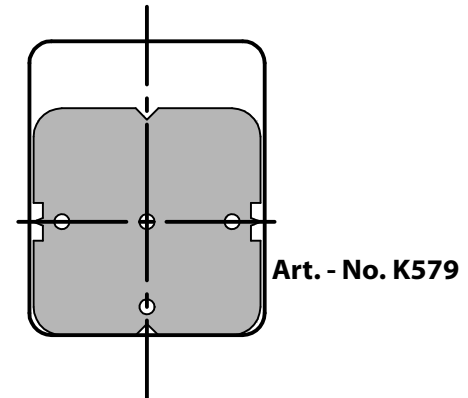

## 3. Assemble connector

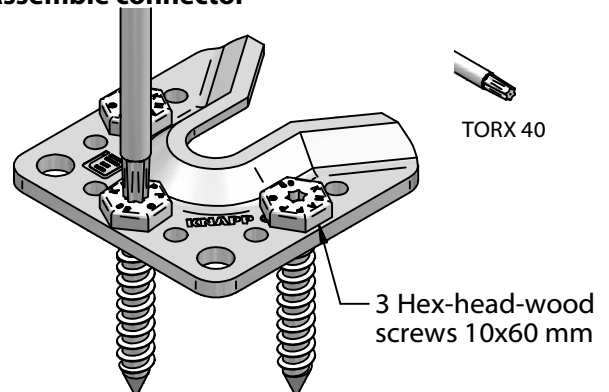

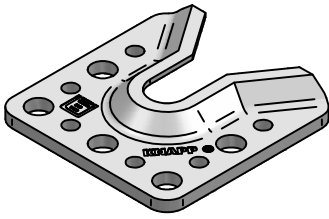

ETA-10/0189

# Construction Manual WALCO® V 80

Wall connector

Retaining spring holding screw M16  
Art. - No. K107



## 1. Drilling

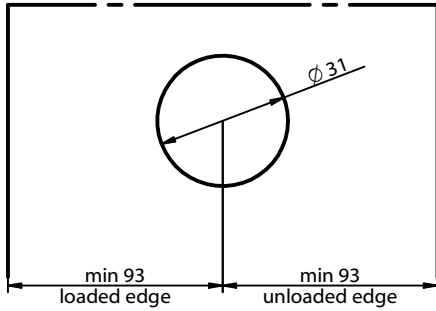

## 2. Screwing the insert screw with special tool

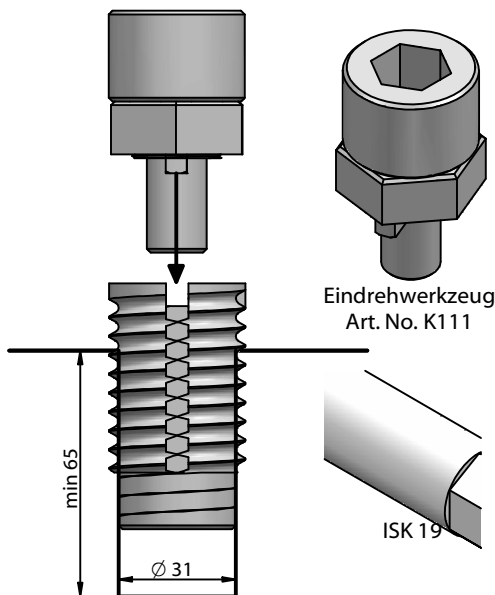

## 3. Screwing holding screw and adjustment of height

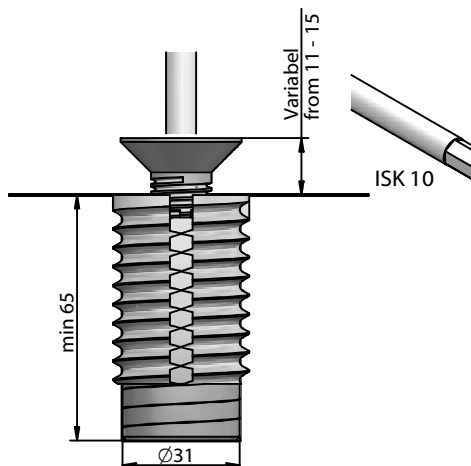

Retaining holding screw M16  
Art. - No. K105



## 1. Drilling the two holes

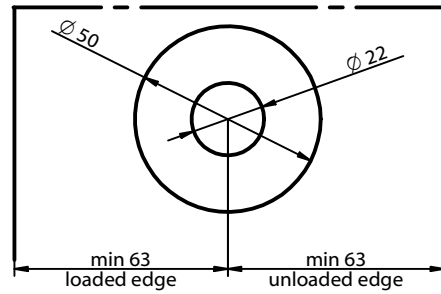

## 2. Screwing insert screw

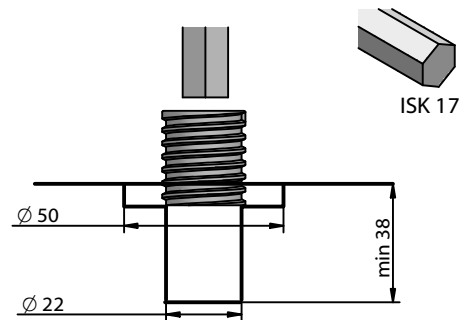

## 3. Screwing retaining holding screw and nut M16

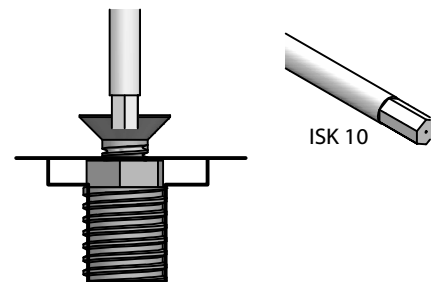

## 4. Fixing the screw and nut in the ideal position

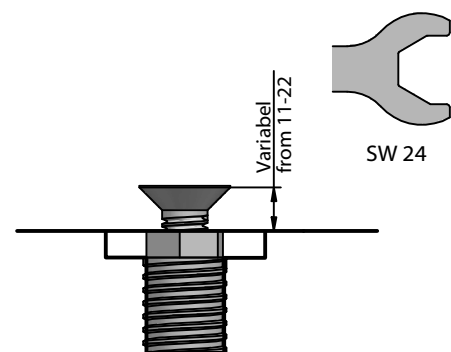

This drawing is the exclusive property of Knapp GmbH.

© Knapp GmbH. All measures in mm - Errors excepted. VERSION 12.08.2013

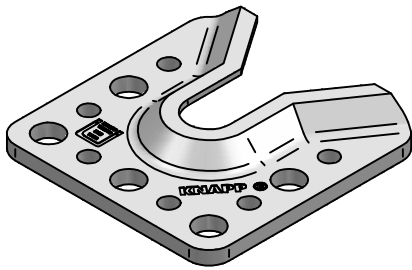

# Construction Manual

# WALCO® V 80 VK D16

Wall connector

Collar bold holding screw  
Art. - No. K109



WALCO V 80



### 1. Drilling

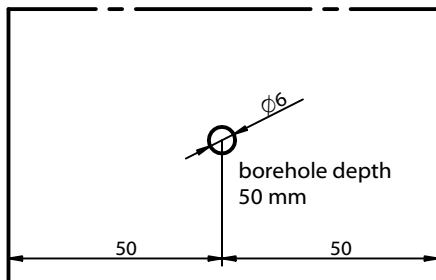

### 2. Screwing countersink screw into Collar bolt

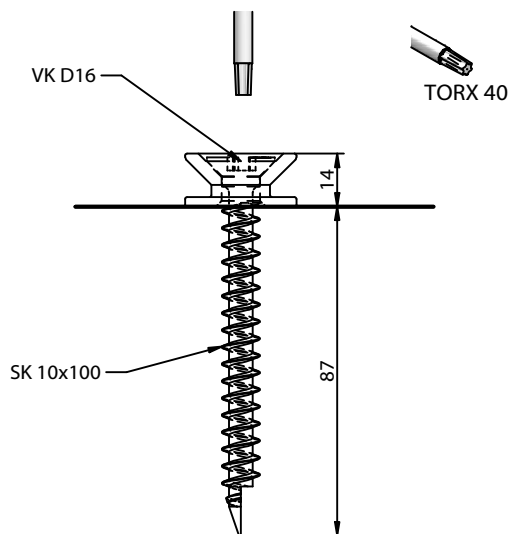

**Tip:** If the collar bold holding screw requires a higher height, one additional washer can be laid under the collar screw washer.  
The full thread screw can be pre drilled with a  $\phi 7$  mm diameter.

### 1. Machined edge

Minimum milled dimension

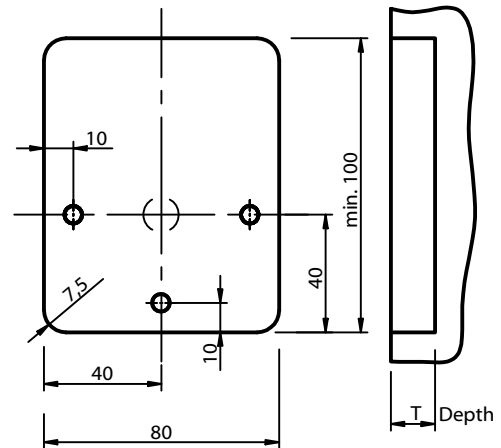

Depth: 15 mm without joints => tight fitting  
13 mm easy to connect (2mm gap)

### 2. Marking Connector position with scribing jig

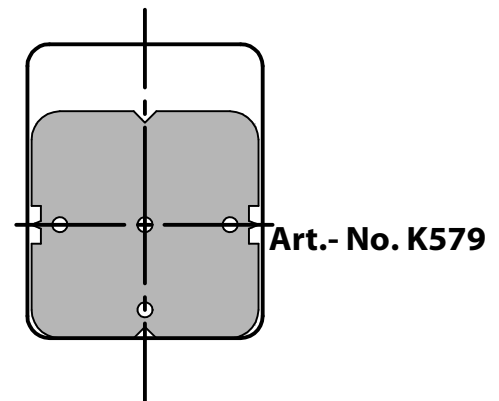

### 3. Assemble connector

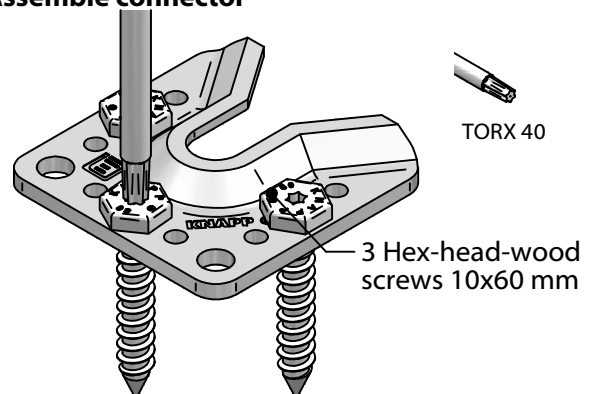

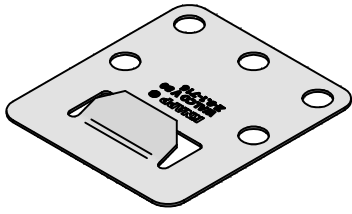

# WALCO® V 80

Wall connector with clip lock

WALCO V Clip lock  
Art. - No. K113

WALCO V 80

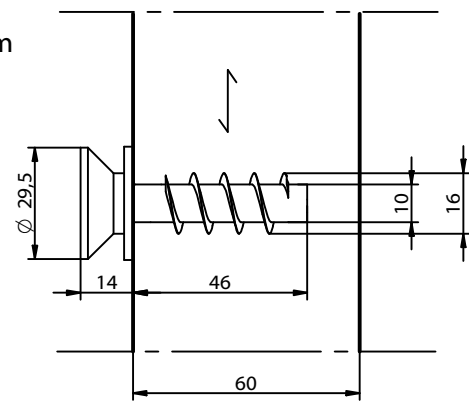
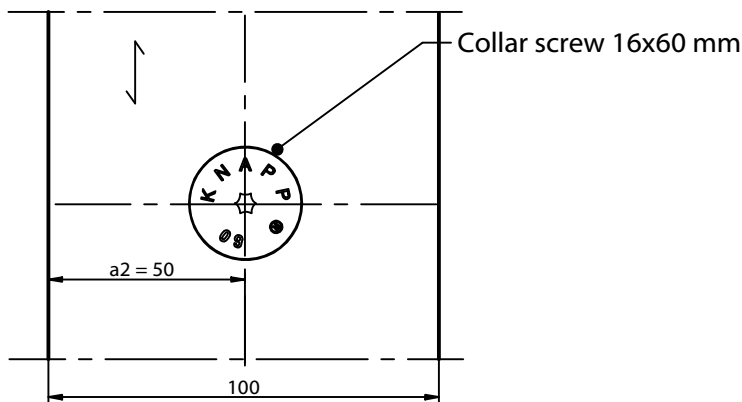
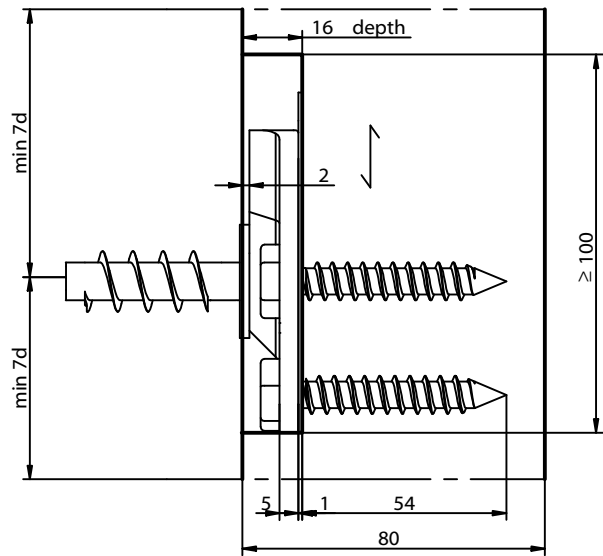
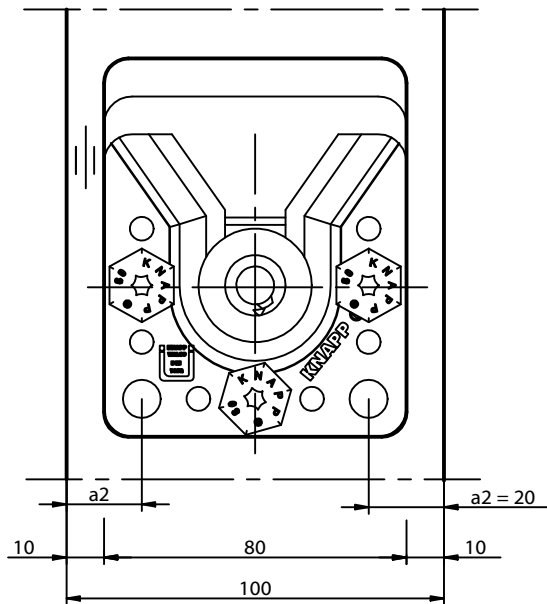

### 1. Positioning

### 2. Insertion

### 3. Locking

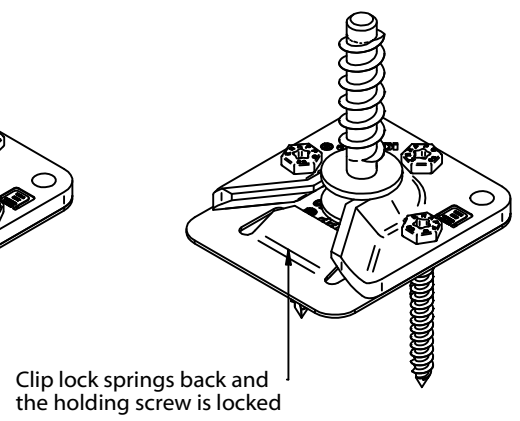
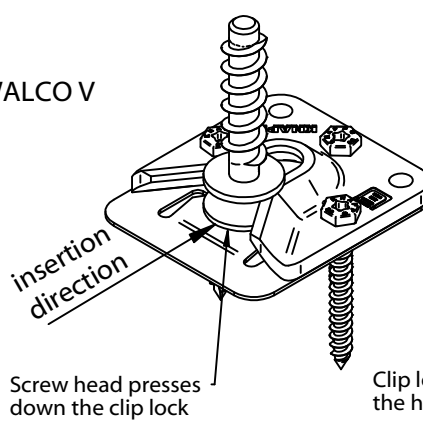
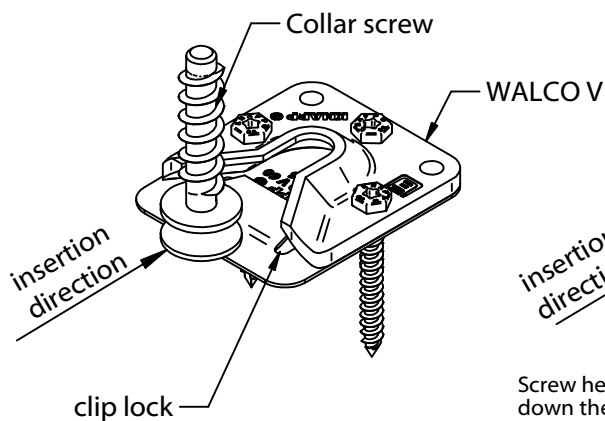

This drawing is the exclusive property of Knapp GmbH.

© Knapp GmbH. All measures in mm - Errors excepted. VERSION 12.08.2013



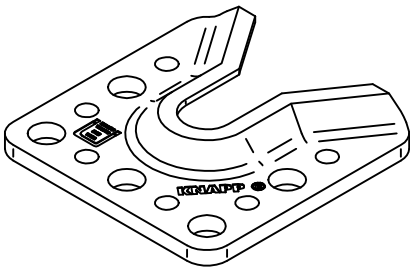

### Vis à collerette 16x60 Réf. K103



#### 1. Percer sur le montant opposé à la ferrure d'accroche et dans son axe

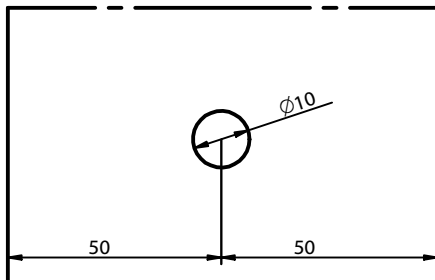

#### 2. Visser la vis à collerette en butée

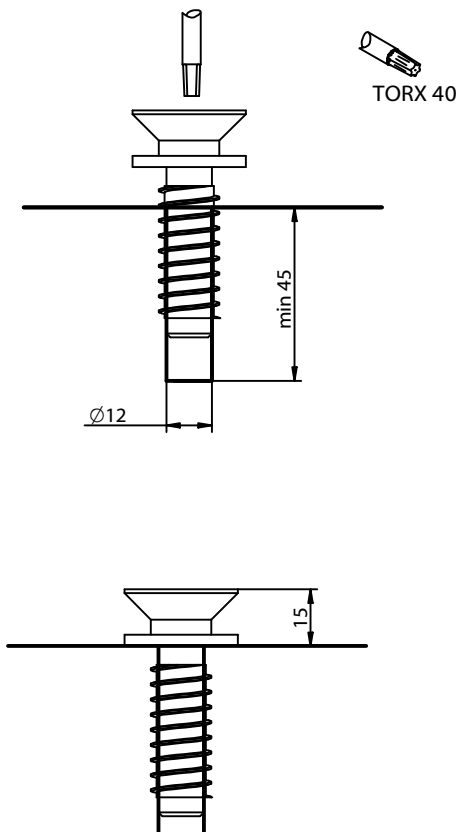

**Note:** La hauteur de vis peut être réglée en rajoutant des rondelles supplémentaire

### WALCO V 80 Ferrure d'accroche



#### 1. Usiner la poche d'encastrement de la ferrure d'accroche

Dimensions de fraisage minimum:

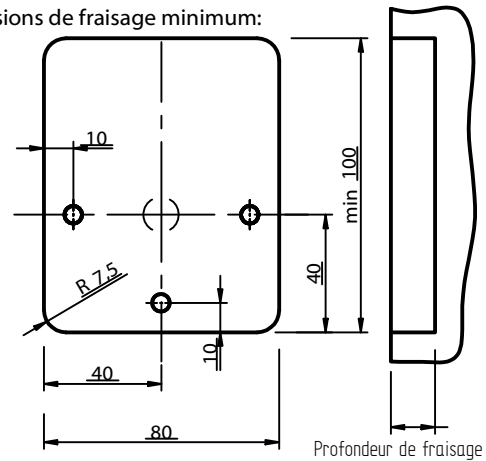

Prof. 13 mm - Montage facile avec 2 mm de jeu  
Prof. 15 mm - Montage jointif sans jeu

Profondeur de fraisage avec insert et vis d'accroche:  
11-22 mm

Profondeur de fraisage avec insert à ressort et vis d'accroche:  
11-17 mm

#### 2. Si besoin pointer les 3 vis de fixation pour la ferrure et pré-percer

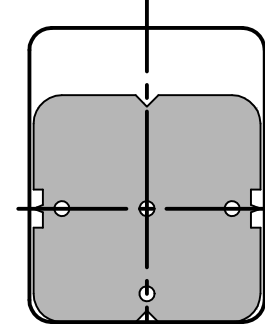

#### 3. Visser la ferrure à son emplacement

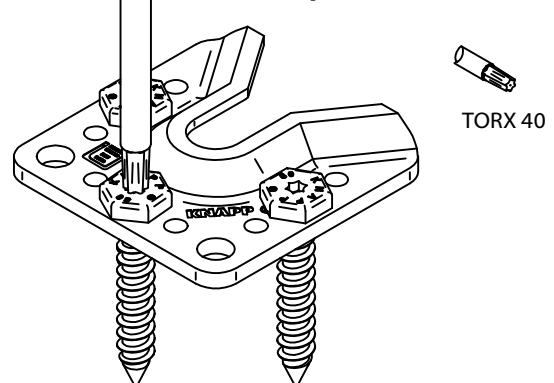

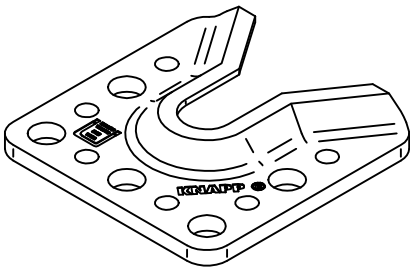

# Notice de montage

# WALCO® V 80

Assemblage d'éléments muraux

## Insert à ressort avec vis d'accroche M16 Réf. K107



1. Percer sur le montant opposé à la ferrure d'accroche et dans son axe

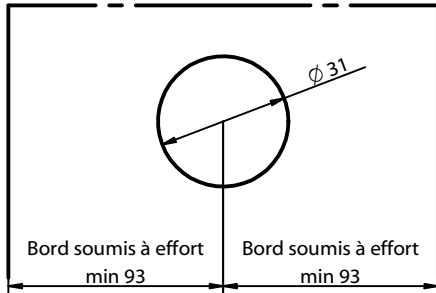

2. Visser l'insert avec l'outil de vissage

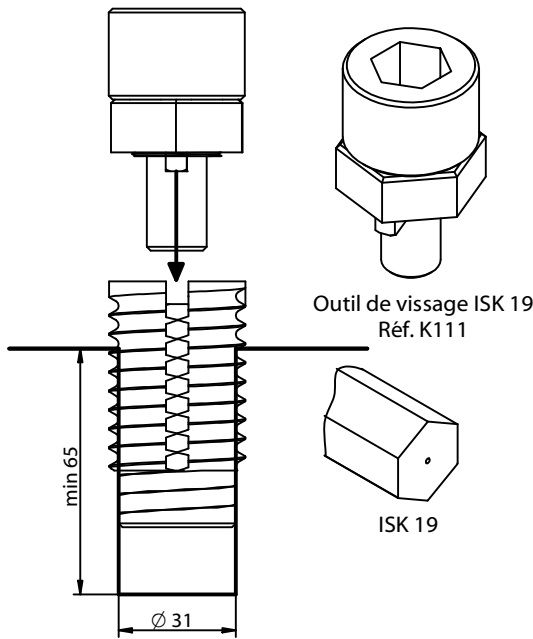

3. Visser la vis d'accroche

4. Régler la hauteur

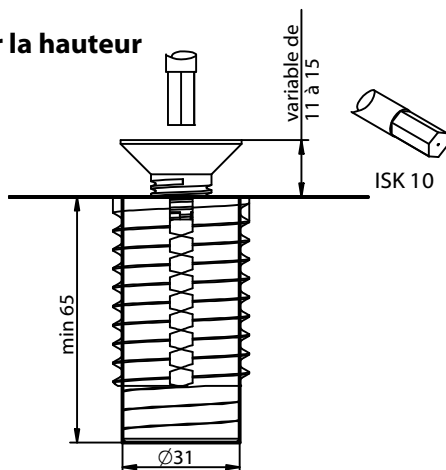

## Insert avec vis d'accroche Réf. K105

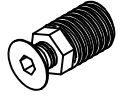

1. Percer sur le montant opposé à la ferrure d'accroche et dans son axe

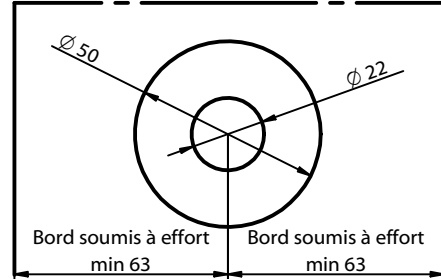

2. Visser l'insert

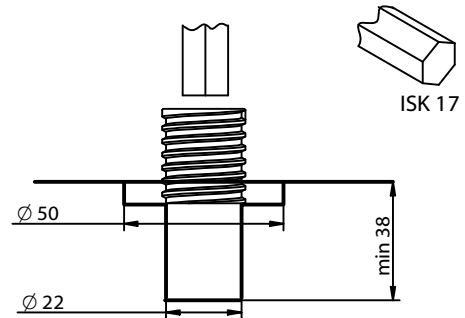

3. Visser la vis d'accroche avec l'écrou

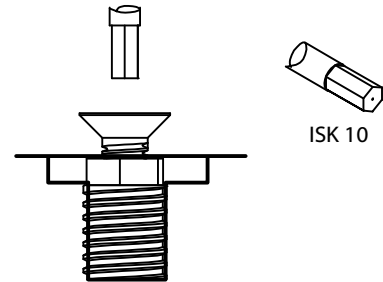

4. Régler la hauteur de vis et la serrer avec l'écrou

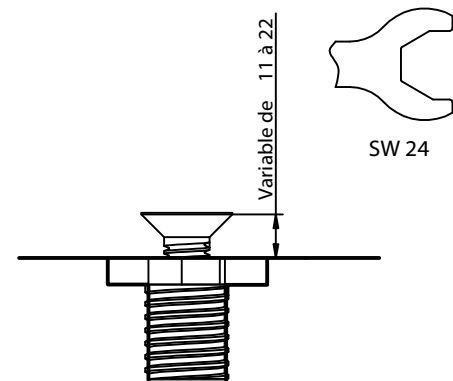

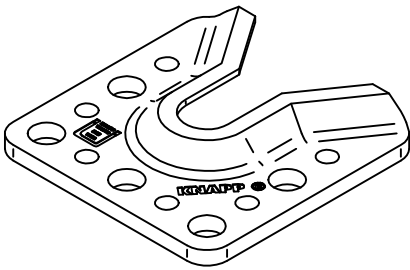

# Notice de montage

# WALCO® V 80

Assemblage d'éléments muraux

## Pièce d'accroche vissée VK D16 Réf. K109



1. Percer sur le montant opposé à la ferrure d'accroche et dans son axe

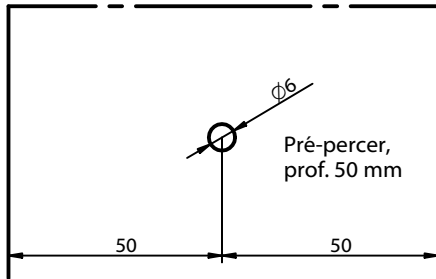

2. Visser la pièce d'accroche

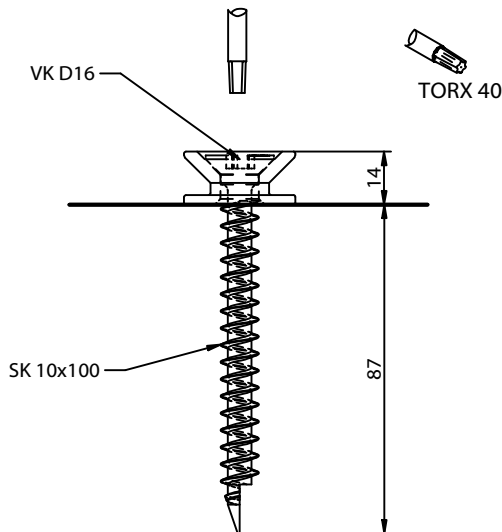

**Remarque:**

La hauteur peut se régler à l'aide de rondelles. La vis à filetage complet peut être pré-percée avec une mèche  $\varnothing$  7 mm !

## WALCO V 80 Ferrure d'accroche



1. Usiner la poche d'encastrement de la ferrure d'accroche

Dimensions de fraisage minimum:

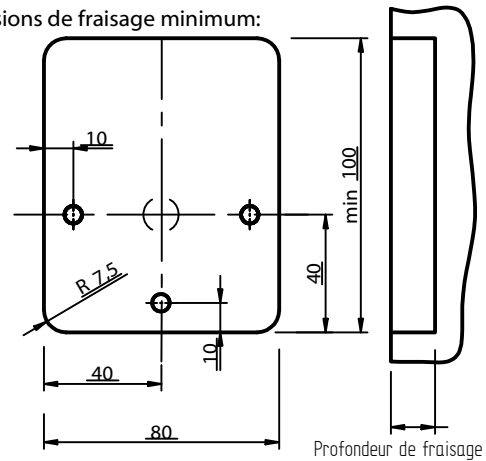

Prof. 13 mm - Montage facile avec 2 mm de jeu  
Prof. 15 mm - Montage jointif sans jeu

2. Si besoin pointer les 3 vis de fixation pour la ferrure et pré-percer

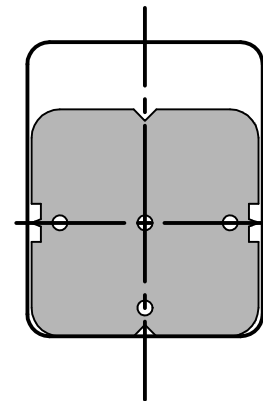

3. Visser la ferrure à son emplacement

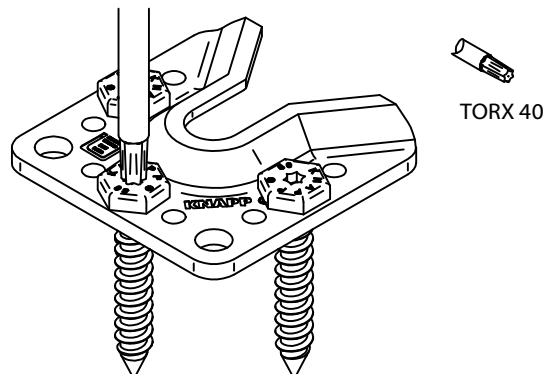

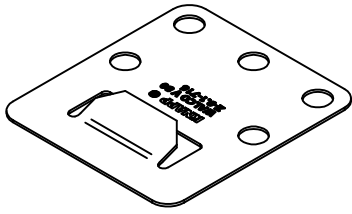

# WALCO® V 80

## Platine de verrouillage

Platine de verrouillage WALCO V80

Réf.: K113

WALCO V 80

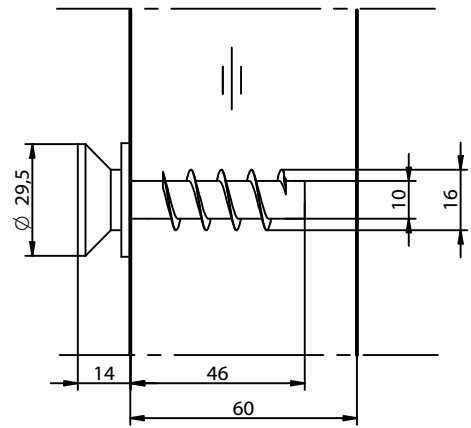
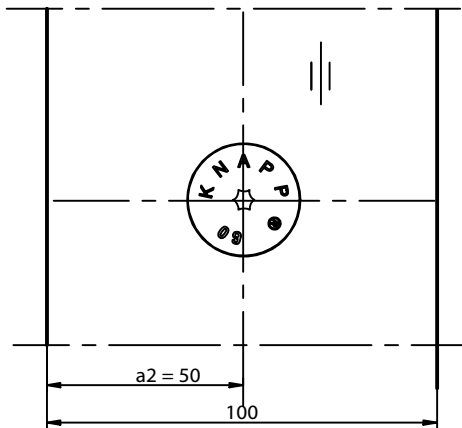
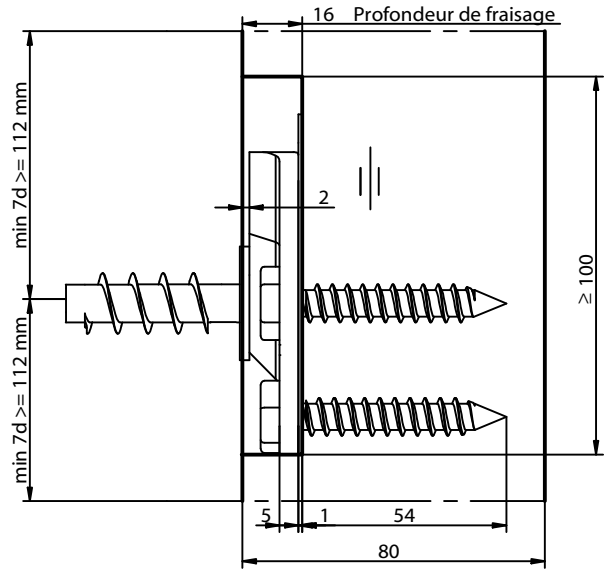
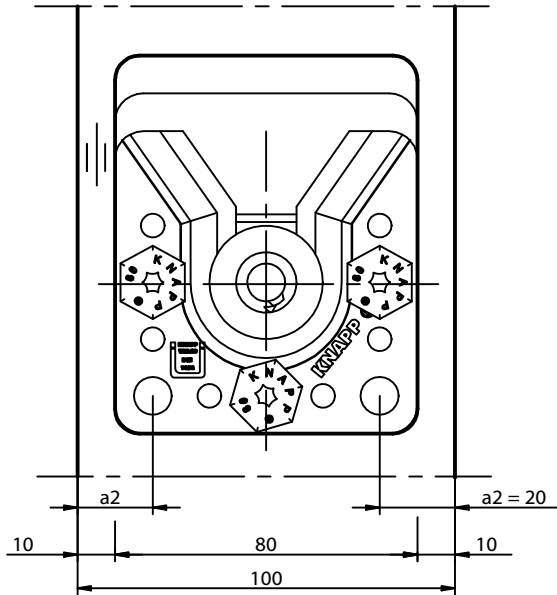
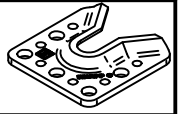

### 1. Mise en position

### 2. Emboiter

### 3. Verrouillage automatique

