

Art. Nr. Z403

Verbinder für Haupt- und Nebenträgeranschlüsse

T-Joint D35/W45

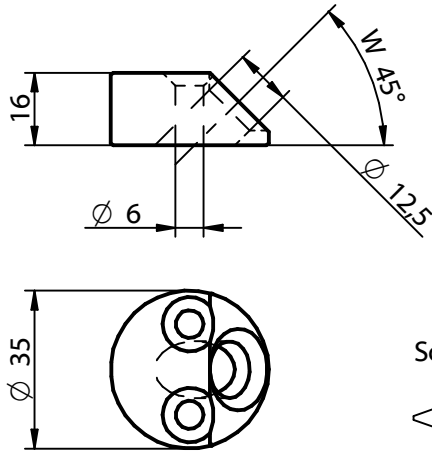

Verbindungen - Schema

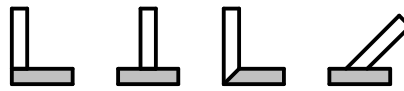

Schraube SK $\phi 5$ / $\phi 6$ mm x Länge



Schraube SK $\phi 8$ / $\phi 10$ / $\phi 12$ mm x Länge

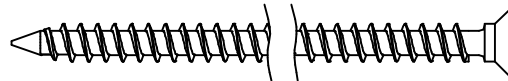

KNAPP Bohrschablone (optional)

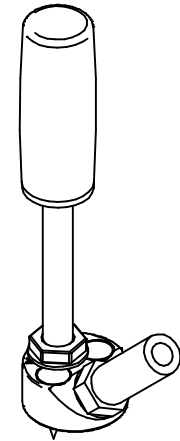

1. Bearbeitung - Bohren / Fräsen

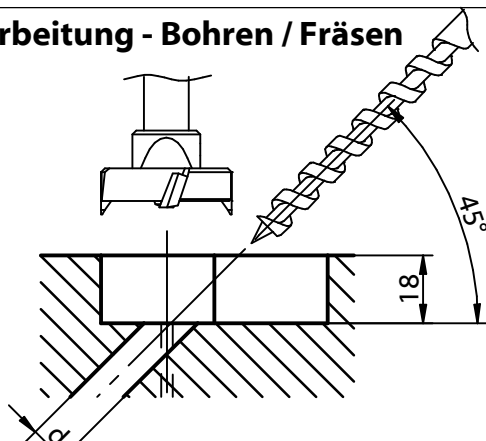

Bohrbild

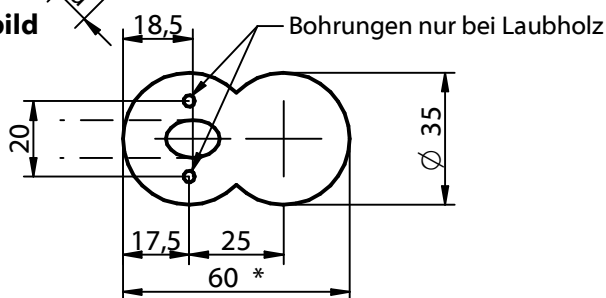

* ... Maß bei händisch durchgeführten Bohrungen, min. 50 mm bei maschinell durchgeführten Bohrungen

Fräsbild

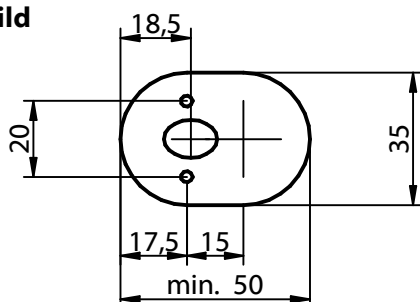

2. Schrauben- / Bohrdurchmesser

Teil A	ϕ Schrauben	ϕ Bohrung
Nadelholz	5	-
	6	-
Laubholz	5	3,5
	6	4

Teil A	ϕ Schrauben	ϕ Bohrung
Nadelholz und Laubholz	8	8
	10	10
	12	12

Teil B	ϕ Schrauben	ϕ Bohrung
Nadelholz	8	-
	10	-
	12	-
Laubholz	8	6
	10	7
	12	9

Montager Reihenfolge:

1. T-Joint einlegen
2. T-Joint fixieren
3. Verbindung herstellen

