

T-Joint D30/W30

Réf. Z617

Solution de renfort et d'assemblage universel

T-Joint D30/W30

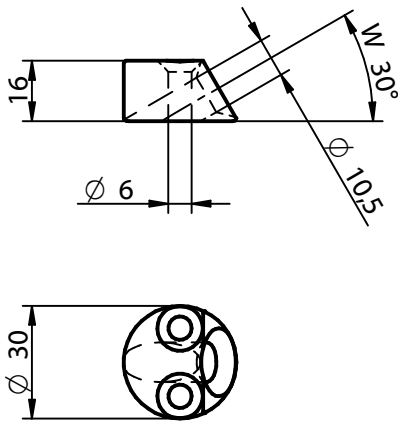

Possibilités d'assemblage

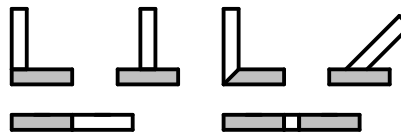

Vis TF $\phi 5$ ou $\phi 6$ mm x longueur
(suivant application)

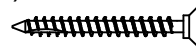

Vis TF $\phi 8$ ou $\phi 10$ mm x longueur
(suivant application)

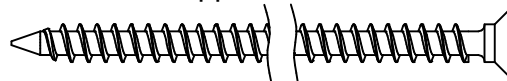

Gabarit de perçage (option)

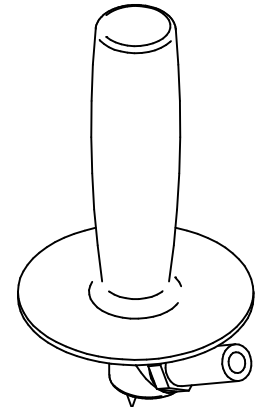

1. Percer / Fraiser

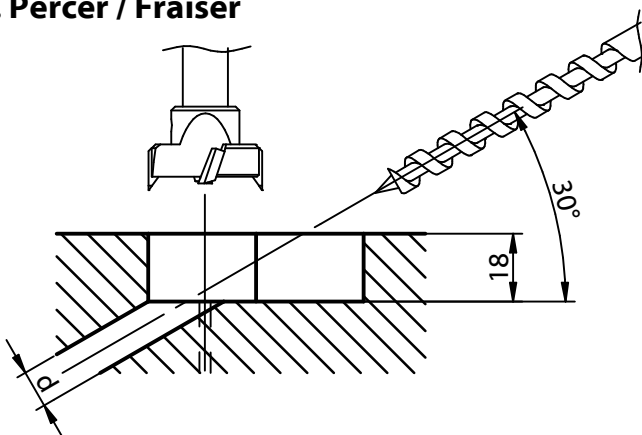

Détail des perçages

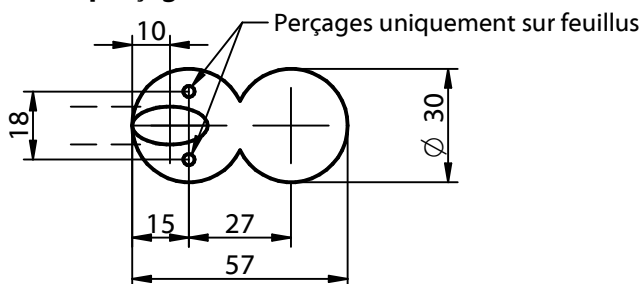

Détail du fraisage

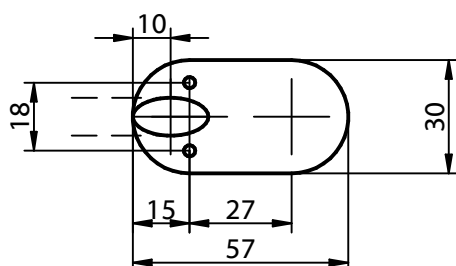

2. Vis / diamètres de perçage

Pièce A	ϕ vis	ϕ perçage
Résineux	5	-
	6	-
Feuillus	5	3,5
	6	4

Pièce A	ϕ vis	ϕ perçage
Résineux et feuillus	8	8
	10	10

Pièce B	ϕ vis	ϕ perçage
Résineux	8	-
	10	-
Feuillus	8	6
	10	7

Processus de montage:

1. Insérer T-Joint
2. Fixer T-Joint
3. Réaliser l'assemblage

