



T-Joint D20/W45

Réf. Z606

Solution de renfort et d'assemblage universel

T-Joint D20/W45

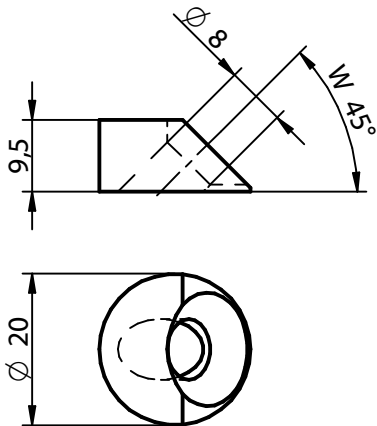

Possibilités d'assemblage

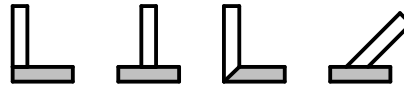

Vis TF $\phi 6$ mm x longueur
(suivant application)

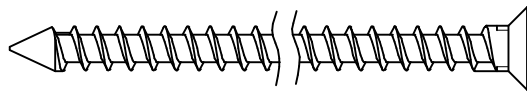

Gabarit de perçage
(option)

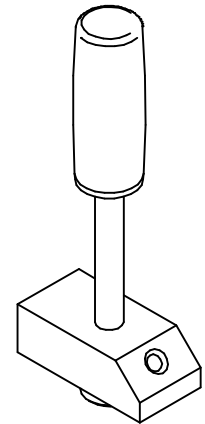

1. Percer et fraiser (option)

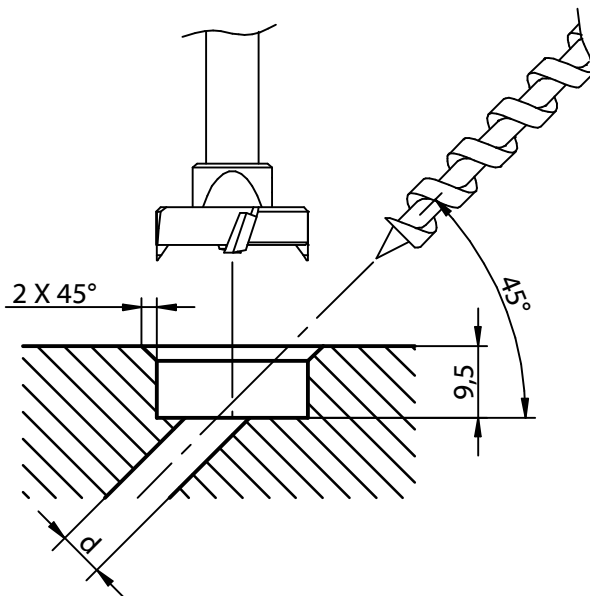

Détail du perçage

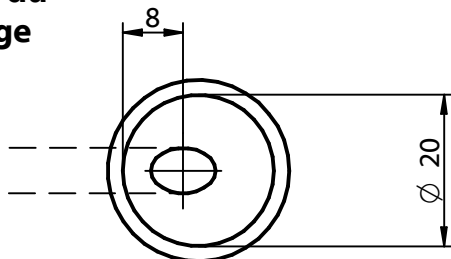

2. Vis / diamètres de perçage

Pièce A	ϕ vis	ϕ perçage
Résineux et feuillus	6	6

Pièce B	ϕ vis	ϕ perçage
Résineux	6	-
Feuillus	6	4

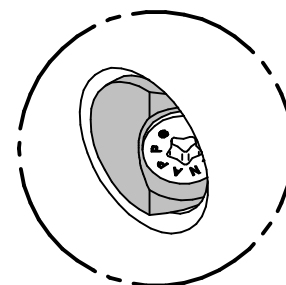
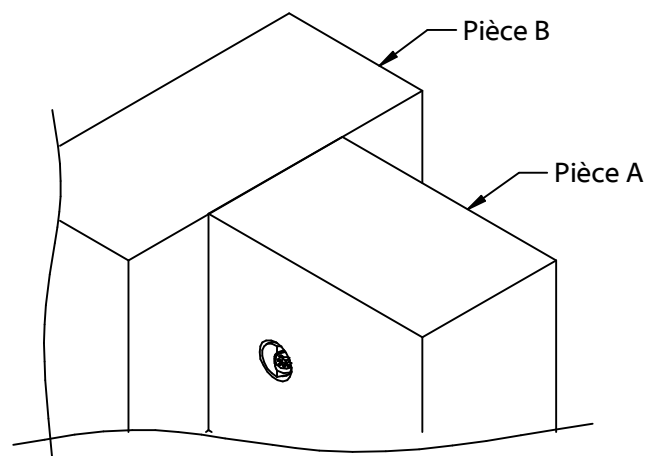



T-Joint D20/W45

Réf. Z606

Solution de renfort et d'assemblage universel

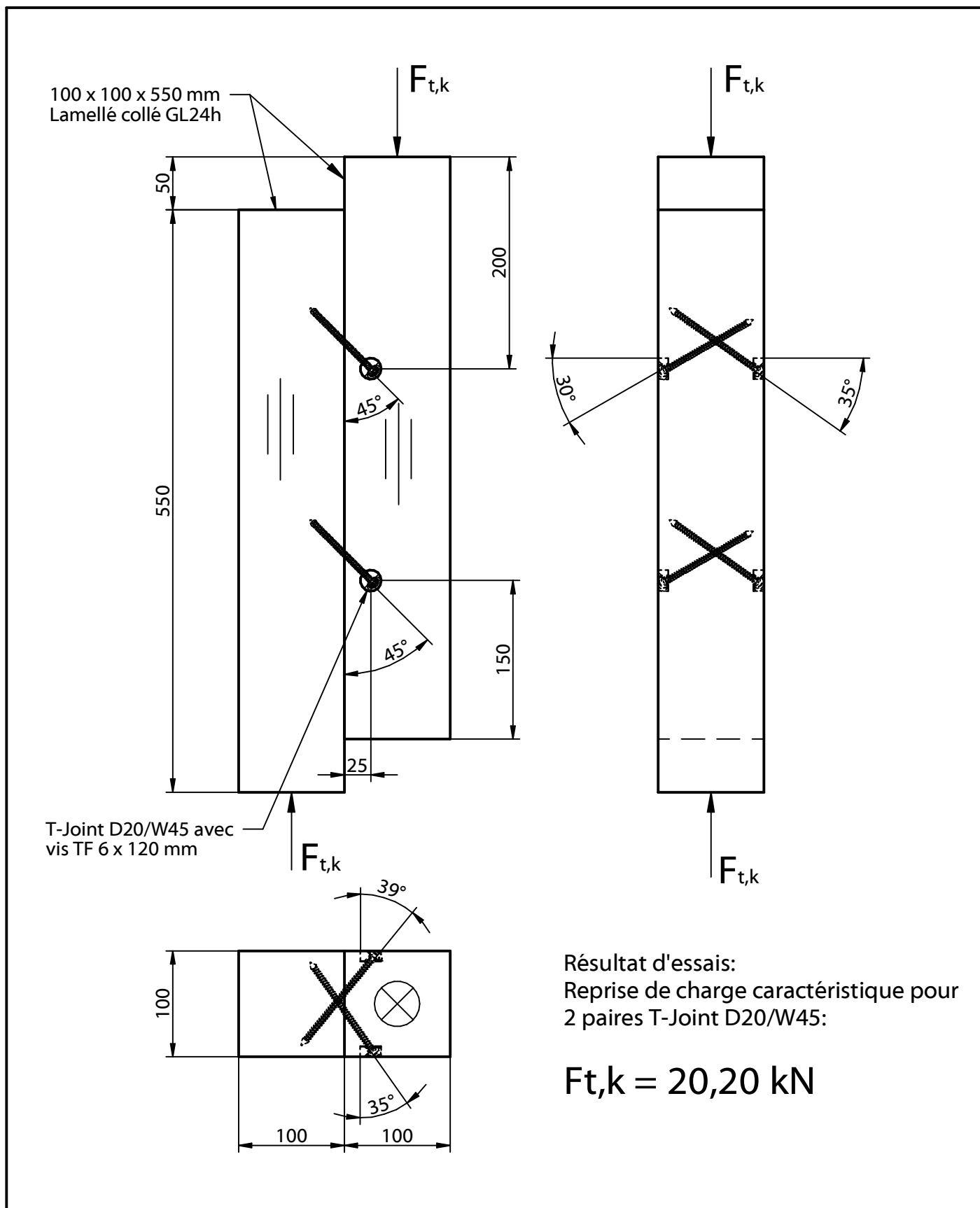

Ces dessins sont la propriété de Knapp GmbH.

© Knapp GmbH. Toutes dimensions en mm - sauf erreurs, fautes d'impression ou modifications techniques / all measures in mm - Errors excepted. VERSION 10.08.2018