

Universal Milling Cutter for FIXclip-Profile System GLE18/ GLE20/ GLE20 Plus and FIXclip GLE20 plus

KNAPP[®]
verbinder.com

Instruction Milling Cutter for FIXclip-System

FIXclip-Systems are fastening, glazing and sealing in one for wood alu fixed glazing and lift-and-slide doors.

GLE20 Milling Cutter GLE18 Milling Cutter

Milling head with cutter
FIXclip-Profile GLE20, GLE20 PRUs
and FIXclip GLE20 Plus
Art.-Nr. K656

Milling head with cutter
FIXclip-Profile GLE18
Art.-Nr. K655

Skid depth gage set made of carbide available upon request.

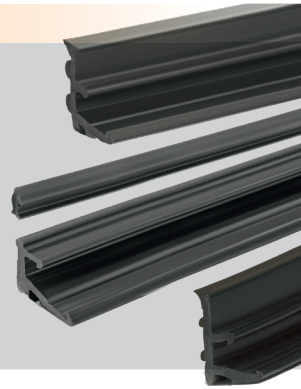
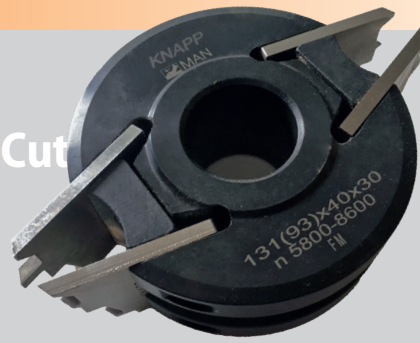

GLE20 & GLE20 Plus

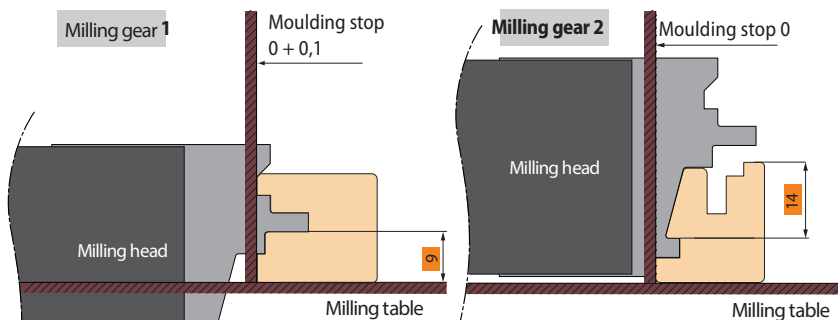

Einstellmaß **9 mm** (Fräsgang 1) und **14 mm** (Fräsgang 2)
Nach Fräsgang 2 Klipsfunktion überprüfen.

GLE18

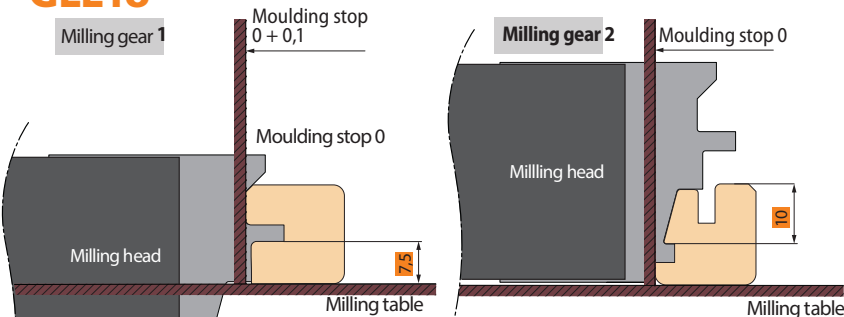

Einstellmaß **7,5 mm** (Fräsgang 1) und **10 mm** (Fräsgang 2)
Nach Fräsgang 2 Klipsfunktion überprüfen.

GLE20 - b 20 - 40 mm

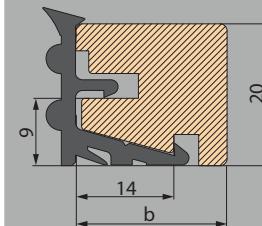

Integrated sealing lip
milling profile for FIXclip-
Profile GLE20

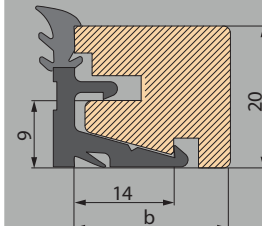

Separate wedge seal
Milling profile for FIXclip-
Profile GLE20 Plus

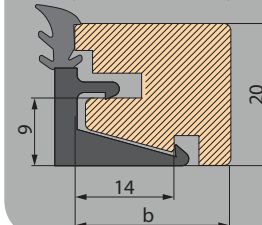

Separate wedge seal
Single hold milling
profile for FIXclip

GLE20 Plus



GLE18 - b 18 - 40 mm

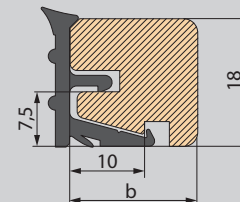

Integrated sealing lip
Milling profile for FIXclip-
Profile GLE18

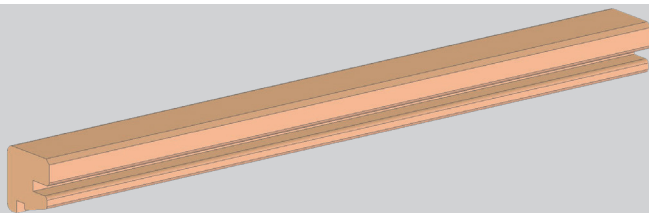

GLE18

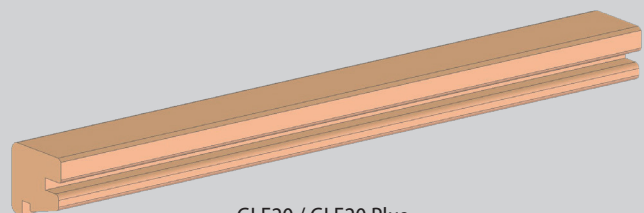

GLE20 / GLE20 Plus

Fräsen der Glasleisten mit Universalfräskopf für jede Tischfräse. Für Profilautomaten empfehlen wir Fräser von Zuani. Alle Einstellmaße sind zu überprüfen, um eine einwandfreie Befestigung der Glasleiste zu gewährleisten.



Further information on: <http://www.knapp-connectors.com/fixclip>

FIXclip-System

Installing options

Completely concealed glazing bead fixture for interior. Flexible use for dry glazing, wood-aluminum fixed glazing, wet glazing and glued glazing.

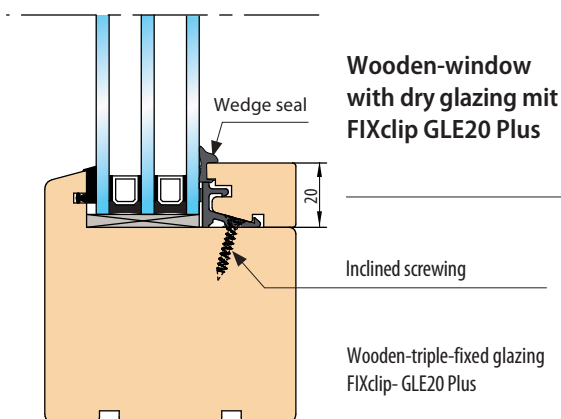
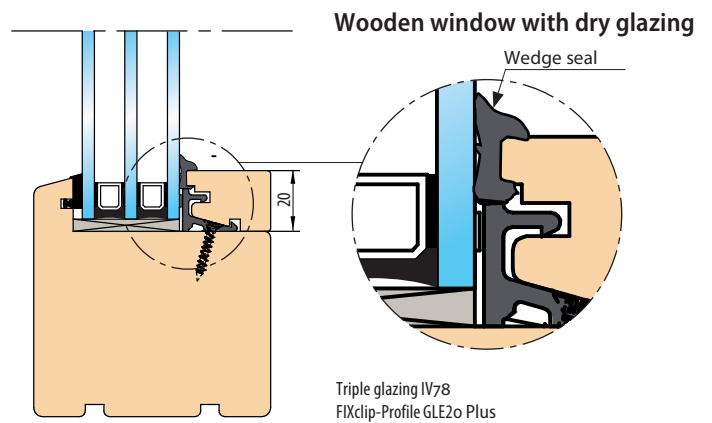
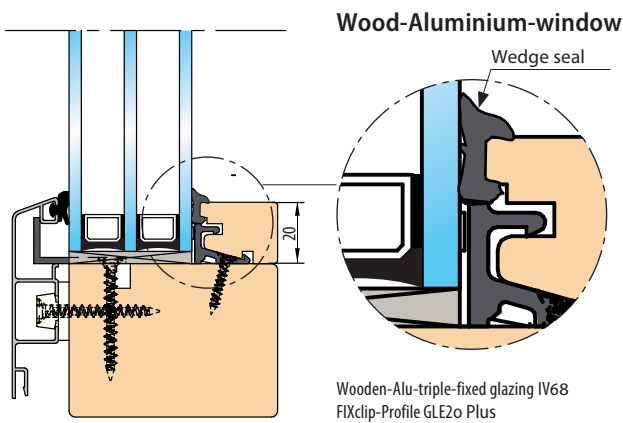
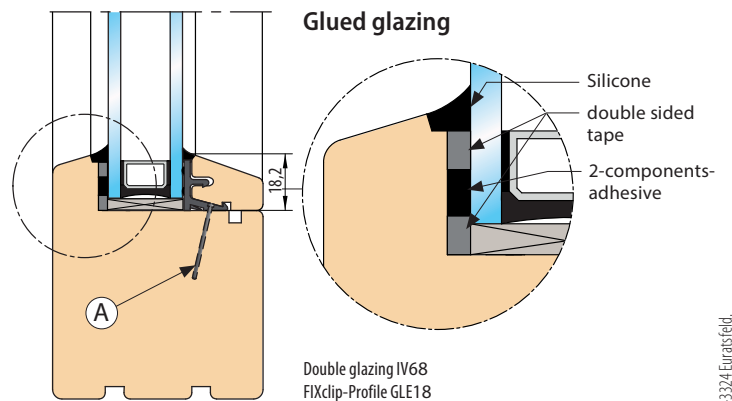
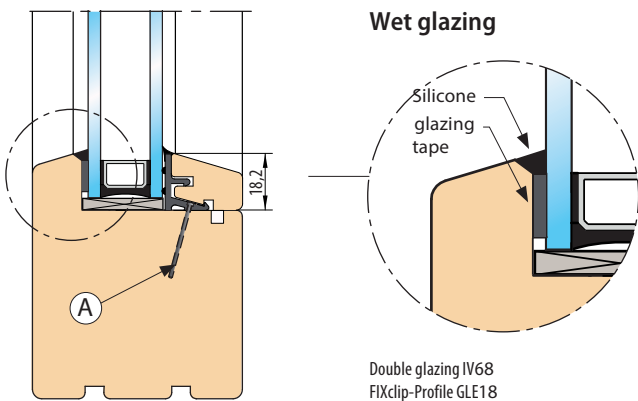
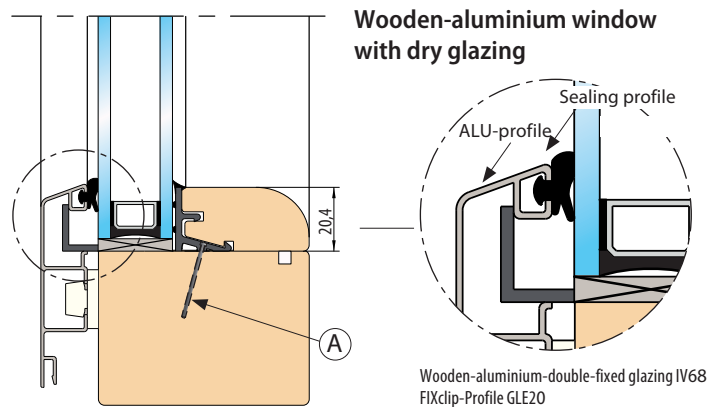
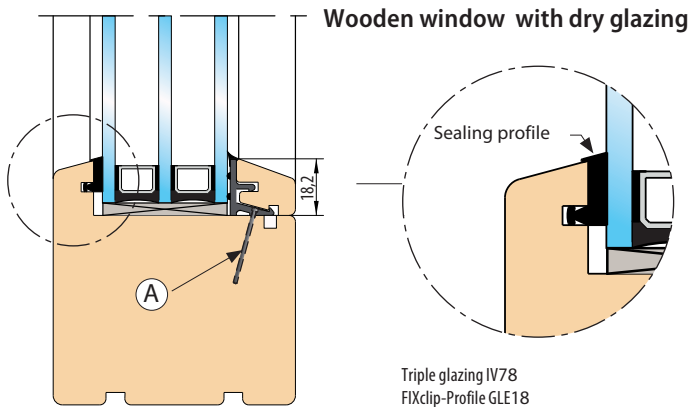

A Fixing with wire nails 1,2x25 mm or CS-screw 3x20 mm

When screwing, resistance category RC1 and RC2, see DIN EN 1627, can be achieved (must be proved by a separate test of the element).

