

# ZIPBOLT 85, 120, 170

Plattenverbinder / Board - Connector  
 Assembleur panneau / Conector para encimeras

1. DE: Bohren und Nuten  
 GB: Drill and groove  
 FR: Percer et rainurer  
 ES: Perforar y hacer ranuras

2. DE: Verbinder einbauen und spannen  
 GB: Fitting connector and tighten  
 FR: Insérer l'assembleur et serrer  
 ES: Montar conector y apretar

DE: Arbeitsplatte  
 GB: Worktop  
 FR: Plan de travail  
 ES: Encimeras

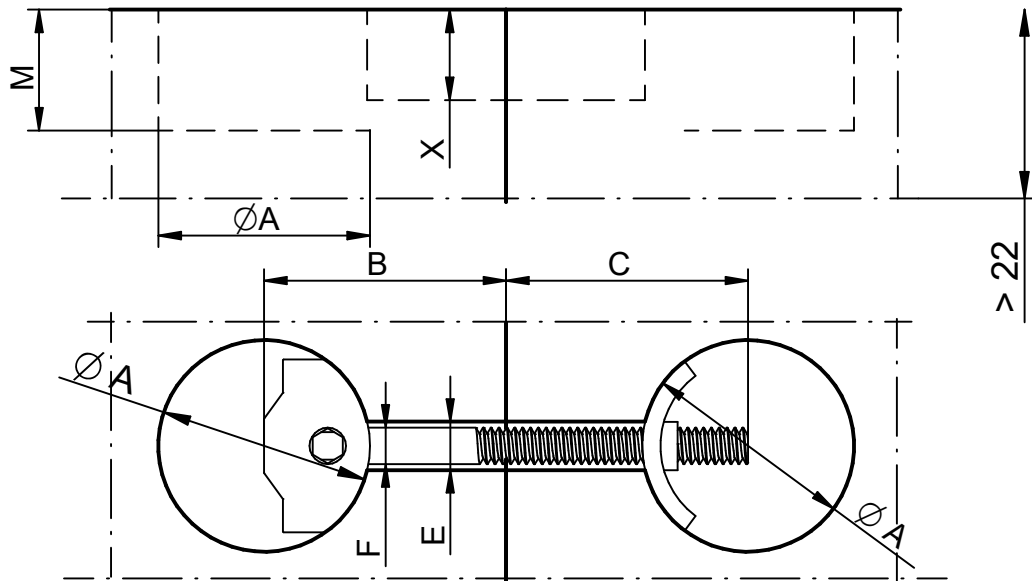
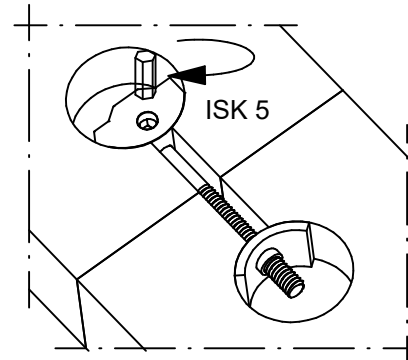
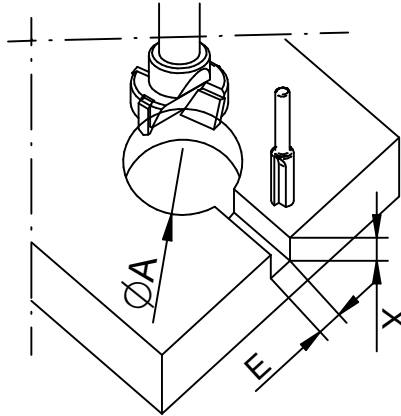

	ZIPBOLT 85 (Z358)	ZIPBOLT 120 (Z366)	ZIPBOLT 170 (Z367)
	[mm]	[mm]	[mm]
ØA	35	35	35
B	33-44	50-62	74-87
C	33-44	50-62	74-87
E	8	8	8
ØF	6	6	6
M	20	20	20
X	15	15	15
Driver	ISK 5	ISK 5	ISK 5

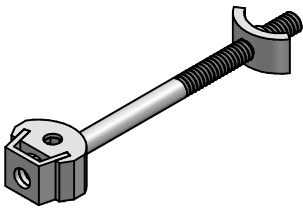

# ZIPBOLT 100 MINI

Art. Nr. Z355

Plattenverbinder / Board - Connector  
 Assembleur panneau / Conector para encimeras

1. DE: Bohren und Nuten  
 GB: Drill and groove  
 FR: Percer et rainurer  
 ES: Perforar y hacer ranuras

2. DE: Verbinder einbauen und spannen  
 GB: Fitting connector and tighten  
 FR: Insérer l'assembleur et serrer  
 ES: Montar conector y apretar

DE: Arbeitsplatte  
 GB: Worktop  
 FR: Plan de travail  
 ES: Encimeras

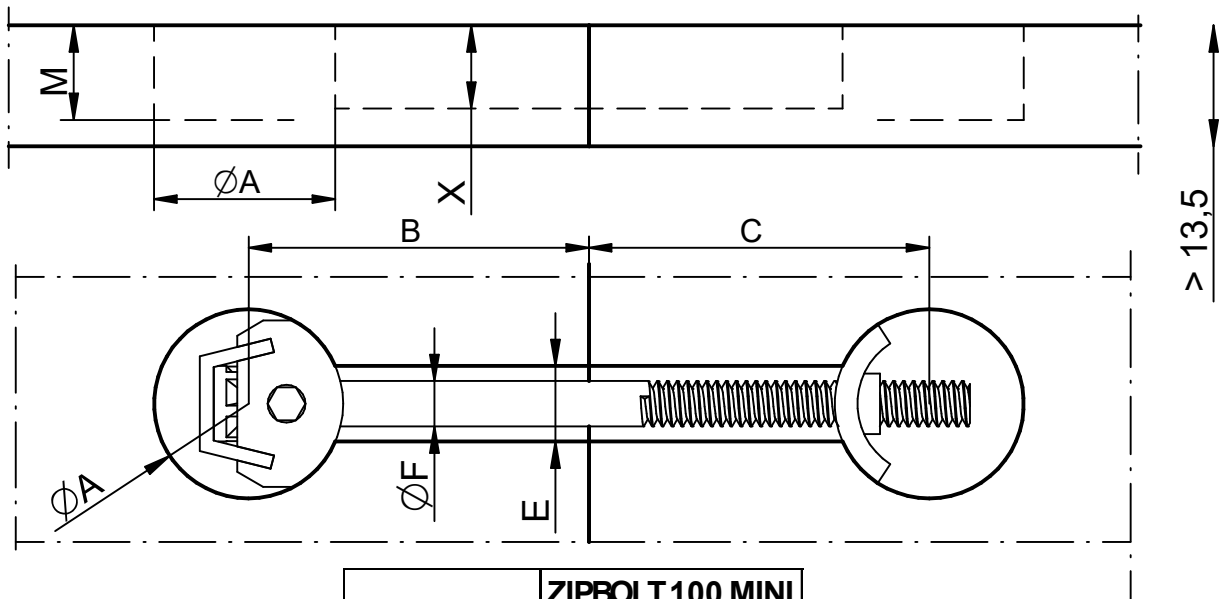
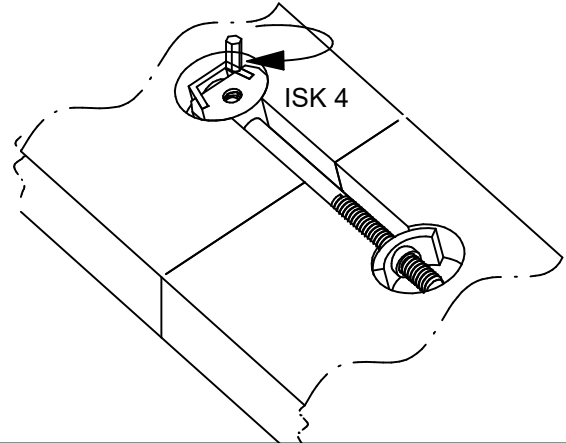
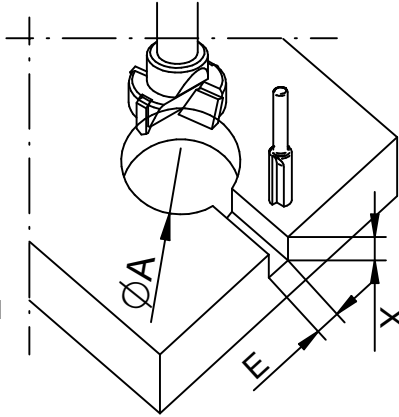

	ZIPBOLT 100 MINI (Z355)
	[mm]
ØA	25
B	42-49
C	42-49
E	10
ØF	6
M	12,5
X	11
Driver	ISK4

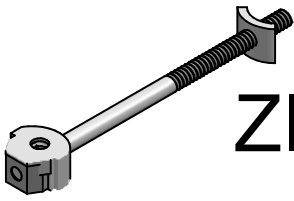

# ZIPBOLT 100 MINI ULTRA SLIM

Art. Nr. Z373

Plattenverbinder / Board - Connector  
 Assembleur panneau / Conector para encimeras

1. DE: Bohren und Nuten  
 GB: Drill and groove  
 FR: Percer et rainurer  
 ES: Perforar y hacer ranuras

2. DE: Verbinder einbauen und spannen  
 GB: Fitting connector and tighten  
 FR: Insérer l'assembleur et serrer  
 ES: Montar conector y apretar

DE: Arbeitsplatte  
 GB: Worktop  
 FR: Plan de travail  
 ES: Encimeras

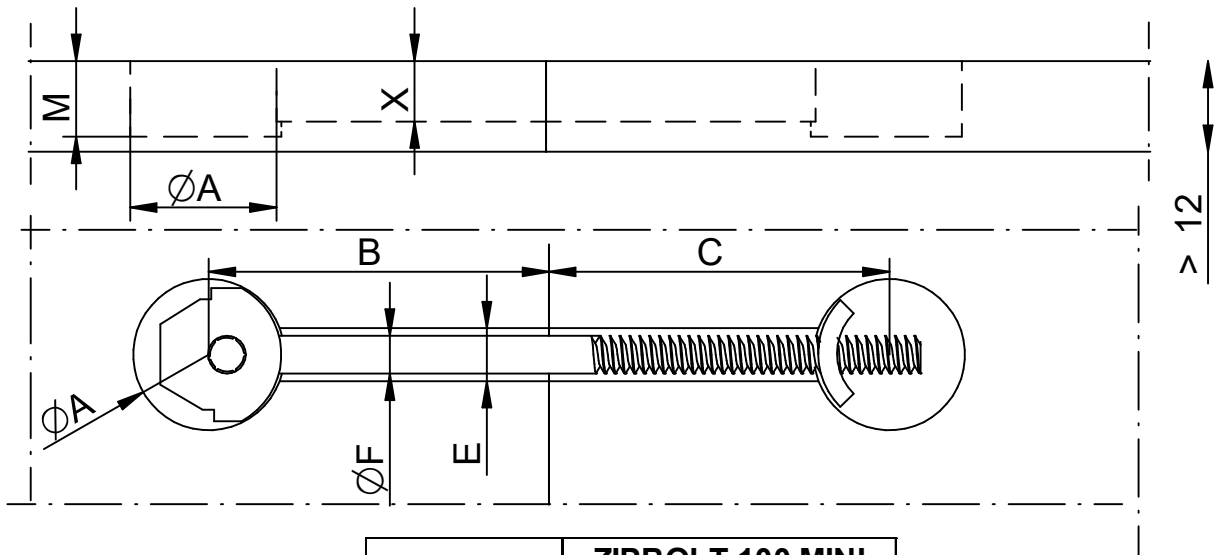
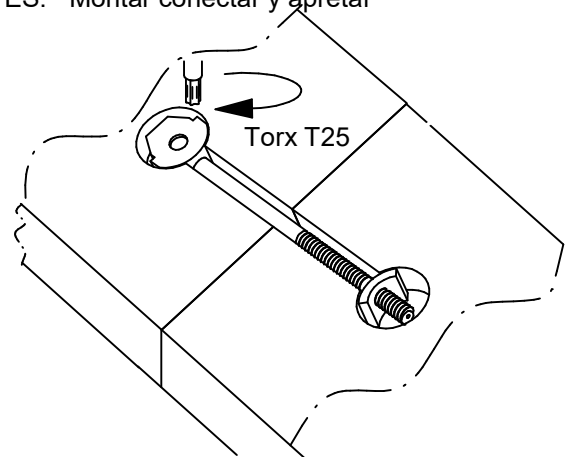
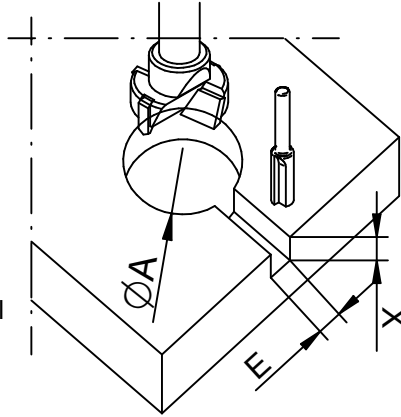

ZIPBOLT 100 MINI ULTRA SLIM (Z373)	
	[mm]
ØA	20
B	43-50
C	43-50
E	5
ØF	4
M	10
X	8
Driver	Torx T25

# ZIPBOLT90 KD

Zargenverbinder / Frame Connector  
 Assembleur de cadre / Marco Conectar

Art. Nr. Z372

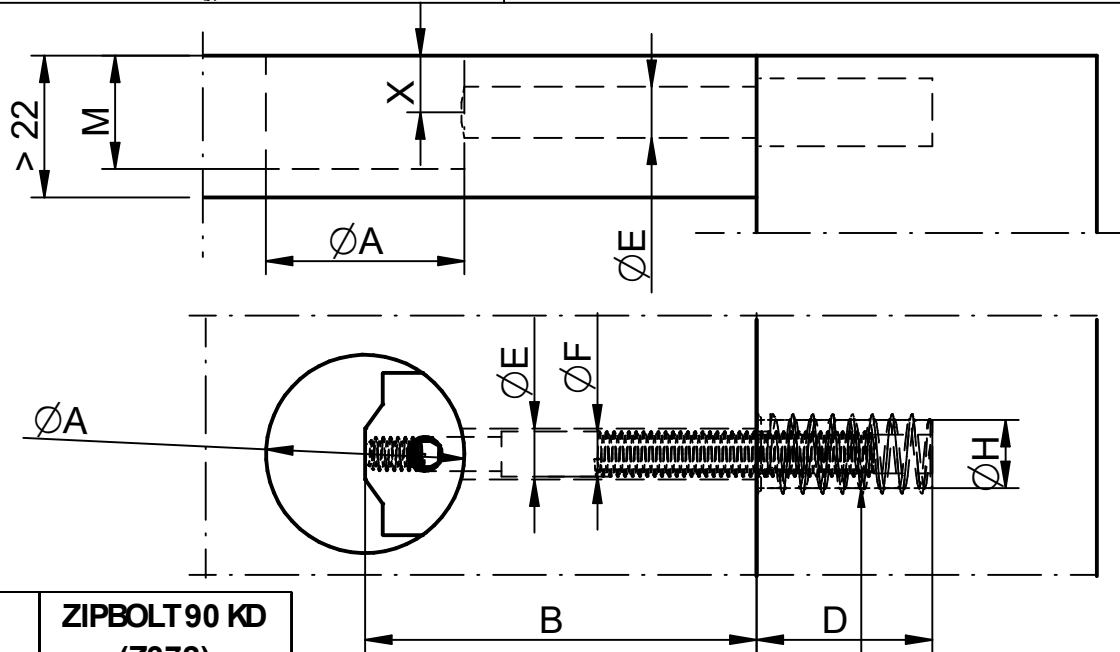
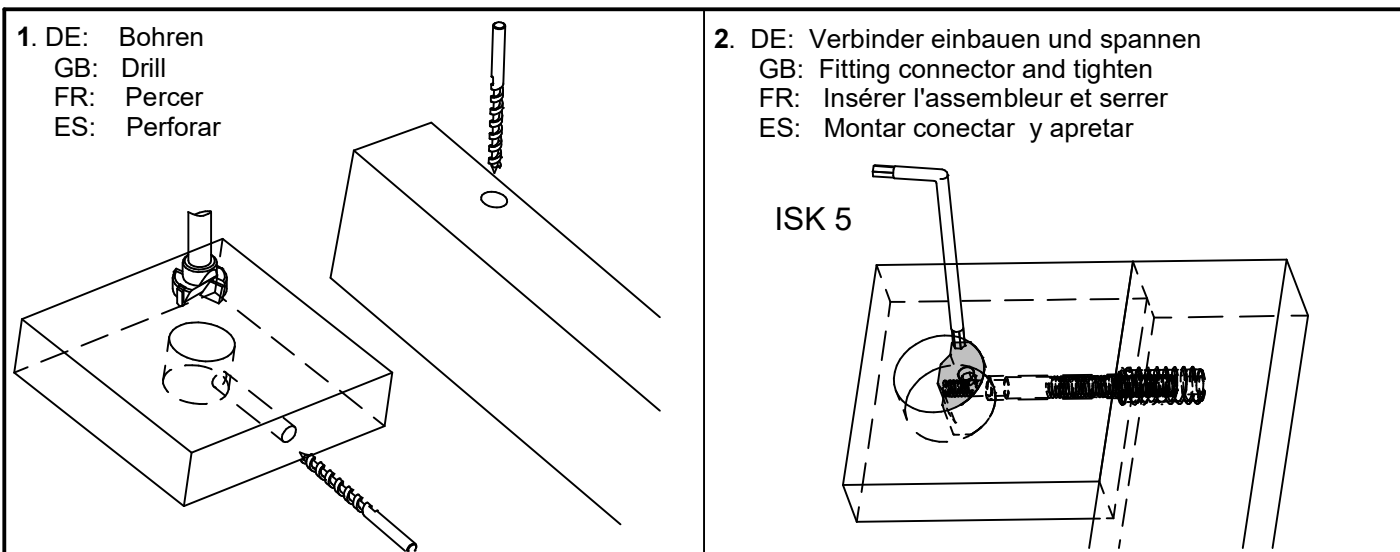

DE: Einschraubmutter  
 GB: Insert Screw  
 FR: Insert à visser  
 ES: Insertar el tornillo

ZIPBOLT 90 KD (Z372)	
	
	[mm]
ØA	35
B	60-65
D	32
ØE	9
ØF	8
ØH	12
M	20
X	10
Driver	ISK 5

Diese Zeichnung ist Eigentum der Knapp GmbH

© Knapp GmbH. Alle Maße in mm - Irrtümer, Druckfehler und Änderungen vorbehalten / all measures in mm - Errors excepted. VERSION 13. 07. 2021

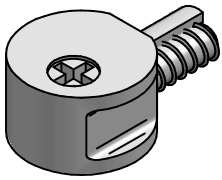

# ZIPBOLT FASTFIT

Art. Nr. Z339

Einteiliger Korpusverbinder für Platten ab 16 mm

One piece corpus connector for boards  $\geq 16$  mm

Assembleur excentrique en une pièce pour panneau à partir d'ép. 16 mm

Ensamblador excéntrico en una pieza por placa a partir de 16 mm

1. DE: Bohren  
 GB: Drill  
 FR: Percer  
 ES: Perforar

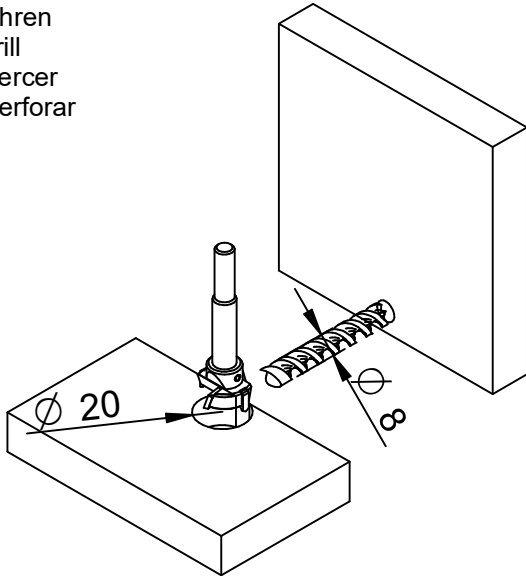

2. DE: Verbinder einbauen  
 GB: Fitting connector  
 FR: Insérer l'assembleur  
 ES: Montar conectar

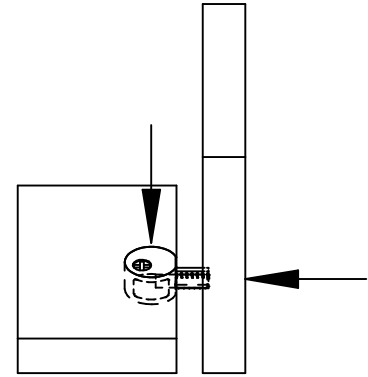

3. DE: Verbinder spannen  
 GB: Tighten connector  
 FR: Serrer l'assembleur  
 ES: Apretar conectar

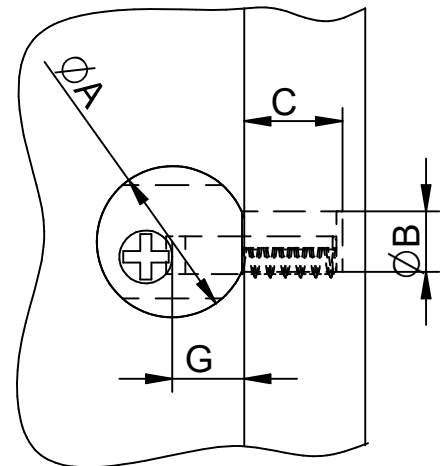
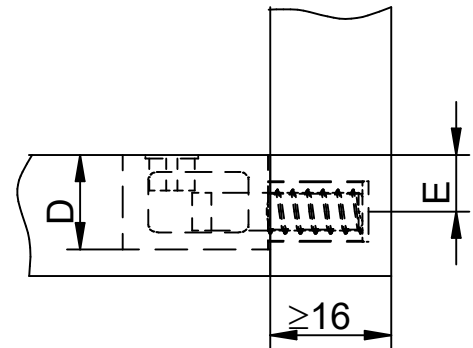
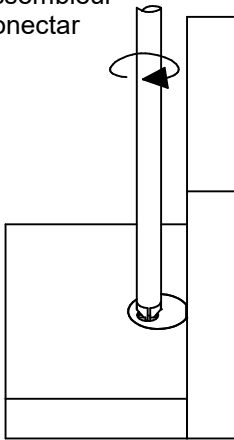

ZIPBOLT FASTFIT (Z339)	
[mm]	
ØA	20
ØB	8
C	12,5-13
D	13
E	7,5
G	9,5