

Montageanleitung Miller® Dowel

Art. - Nr. siehe Online-Store

Mini- X, 1X, 2X

1. ABMESSUNGEN

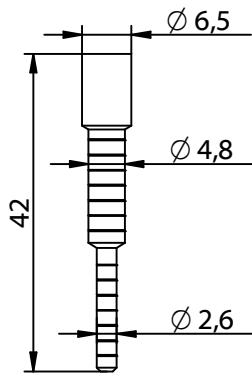

Miller Dowel Mini-X

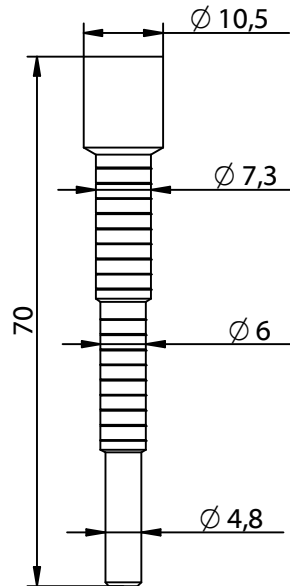

Miller Dowel 1X

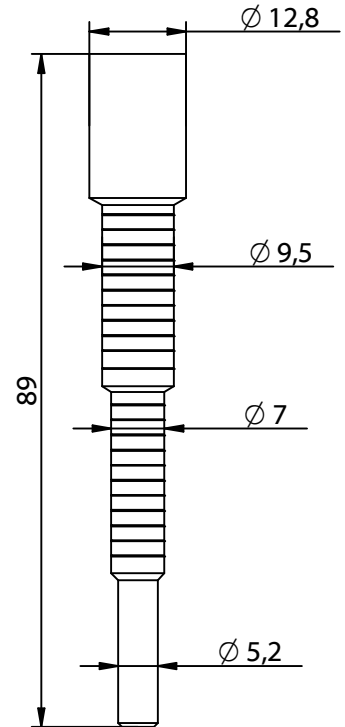

Miller Dowel 2X



Mini-X Miller TruFit Drill Bit Bohrer
(Art.-Nr. Z2003D)



1X Miller TruFit Drill Bit Bohrer
(Art.-Nr. Z2001D)



2X Miller TruFit Drill Bit Bohrer
(Art.-Nr. Z2002D)

Diese Zeichnung ist Eigentum der Knapp GmbH

© Knapp GmbH. Alle Maße in mm - Irrtümer, Druckfehler und Änderungen vorbehalten / all measures in mm - Errors excepted. VERSION 1 02.06.2020

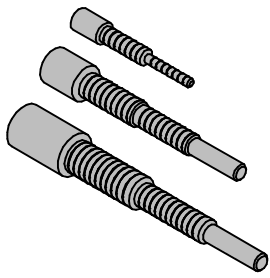

Montageanleitung Miller® Dowel

Art. - Nr. siehe Online-Store

Mini- X, 1X, 2X

2. ARBEITSABLAUF

1. bohren

Mit dem Original"Tru-Fit" Stufenbohrer beide Teile zugleich bohren.

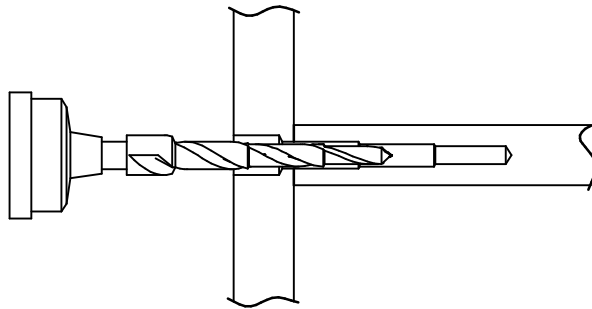

2. beleimen

Knapp- Kleber auf den Dübel aufbringen

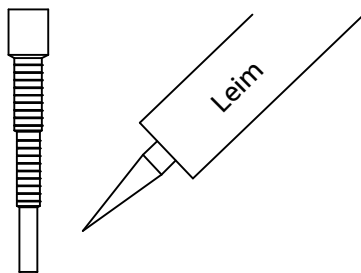

3. Dübel einsetzen

Den Dübel einschlagen. Je nach Wunsch kann der Dübelkopf eben geputzt werden, oder vorstehen.

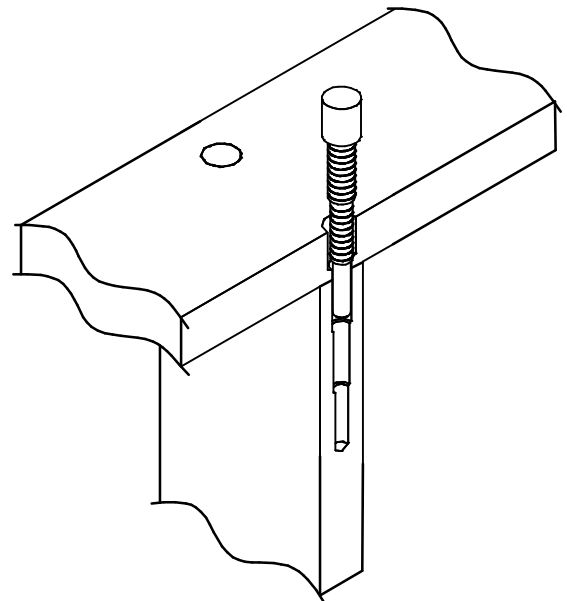
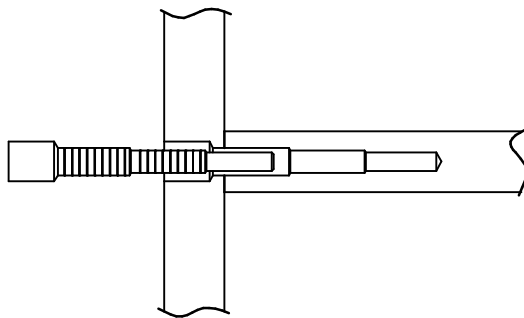

Dübelkopf entweder bündig
oder betont hervorstehend

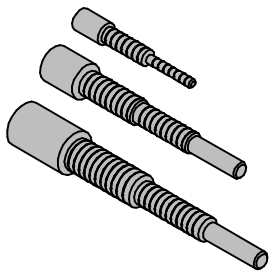

Construction Manual

Miller® Dowel

Art. - No. check our Online-Store

Mini- X, 1X, 2X

1. MEASUREMENTS

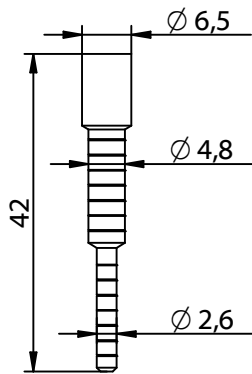

Miller Dowel Mini-X

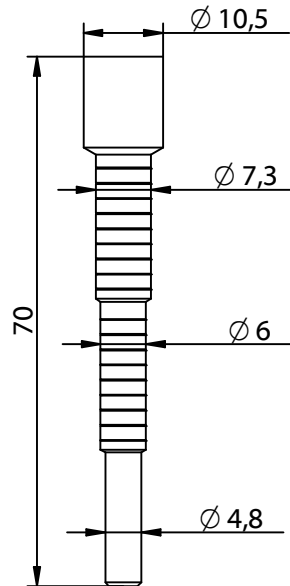

Miller Dowel 1X

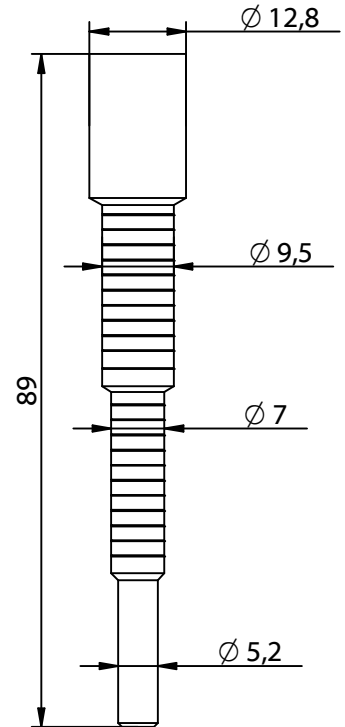

Miller Dowel 2X



Mini-X Miller TruFit Drill Bit (Art.-No. Z2003D)



1X Miller TruFit Drill Bit (Art.-No. Z2001D)



2X Miller TruFit Drill Bit (Art.-No. Z2002D)

This drawing is the exclusive property of Knapp GmbH.

© Knapp GmbH. All measures in mm - Errors excepted. VERSION 1 02.06.2020

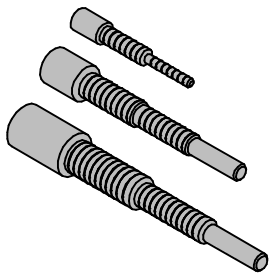

Construction Manual

Miller® Dowel

Art. - No. check our Online-Store

Mini- X, 1X, 2X

2. MOUNTING PROCEDURE

1. drilling

Using the Miller TruFit stepped bit, drill a pilot hole through the top piece and into the substrate.

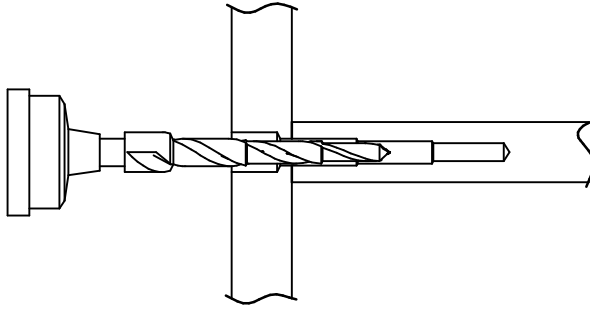

2. glue

Apply Knapp glue to the rib section of the dowel.

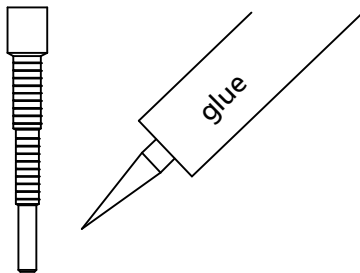

3. Installing Dowel

Insert the dowel. The remaining portion can be trimmed off or sanded until smooth.

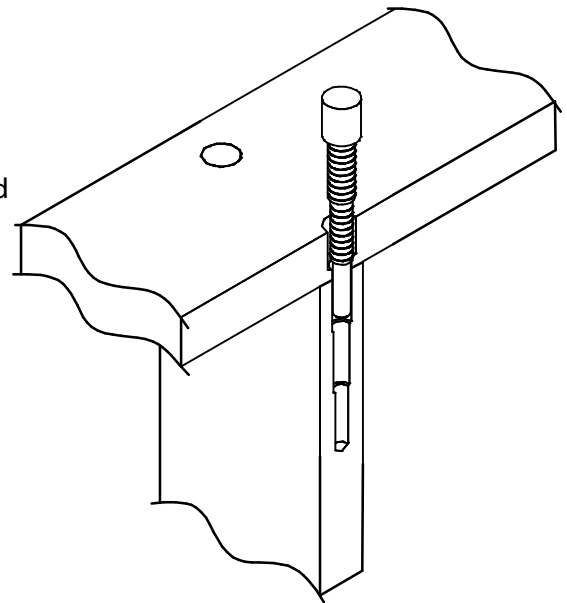
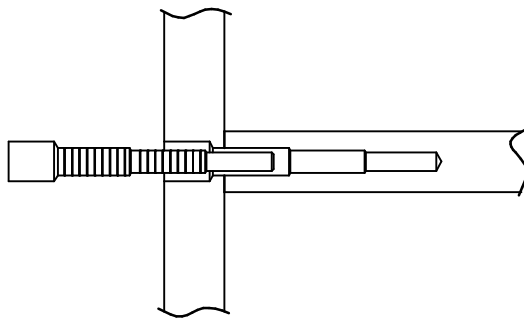

head can be cut or sanded flush

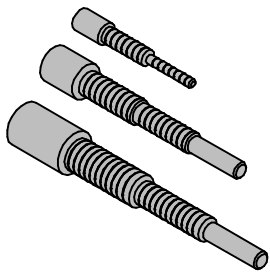

Notice de montage Miller® Dowel

Retrouvez la réf. sur notre site en ligne

Mini- X, 1X, 2X

1. DIMENSIONS

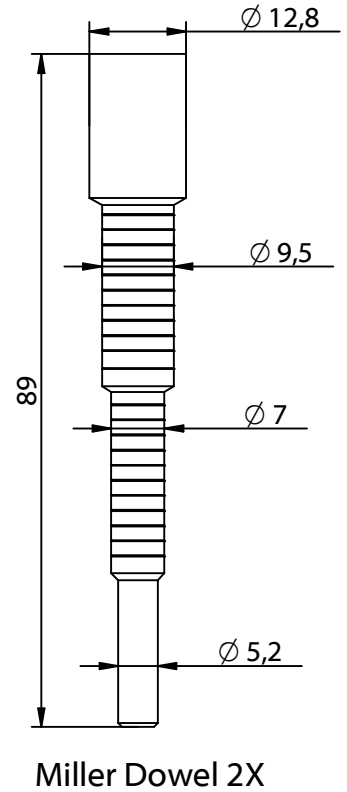
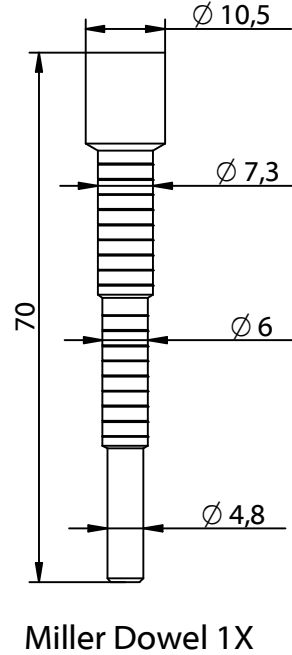
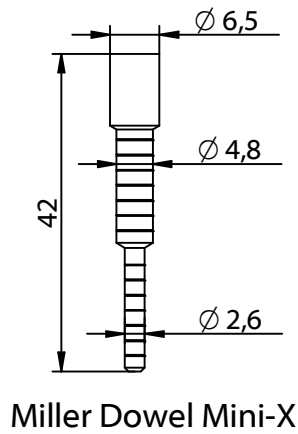

Mèche à étage Mini-X Miller TruFit
(Réf. Z2003D)



Mèche à étage 1X Miller TruFit
(Réf. Z2001D)



Mèche à étage 2X Miller TruFit
(Réf. Z2002D)

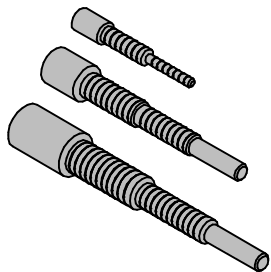

Notice de montage

Miller® Dowel

Retrouvez la réf. sur notre site en ligne

Mini- X, 1X, 2X

2. Mise en œuvre

1. Percer

Percer les deux éléments en même temps avec la mèche étagée "Tru-Fit".

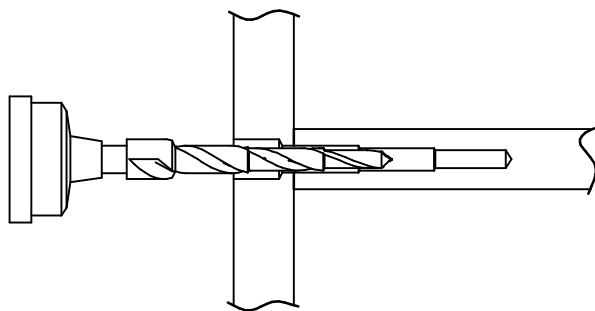

2. Encoller

Encoller le tourillon avec la colle KNAPP.

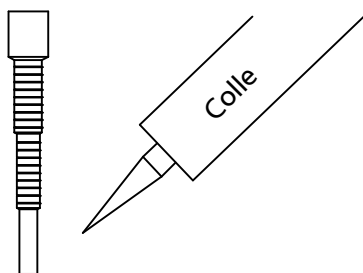

3. Positionner

Enfoncez la cheville. La tête du tourillon peut être coupée à fleur ou poncée, au choix.

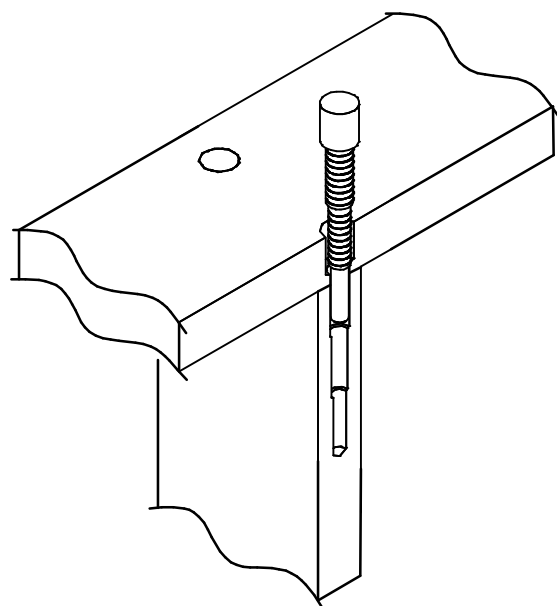
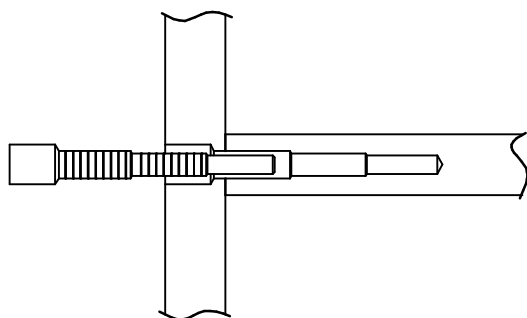

Tête de cheville affleurante ou saillante