

ETA-10/0189

Montageanleitung/Construction Manual

RICON® 80/40 - A2

Pfosten-Riegelverbindung in Edelstahl
 mit Bauzulassung (EU)
post and latch connection in stainless steel
 with construction supervisory approval (EU)

RICON® 80/40

- RICON® SK Scr 8x80
- RICON® SK Scr 8x50
- RICON® SK Scr 5x80
- RICON® SK Scr 5x50
- RICON® Sperrbügel / locking clip

Einzelanschluss single connection	Pfosten-Riegelverbindung post and latch connection
---	--

Riegel Fräsbild /
Milled edge latch

Diese Zeichnung ist Eigentum der Knapp GmbH.

© Knapp GmbH. Alle Maße in mm - Irrtümer, Druckfehler und Änderungen vorbehalten / all measures in mm - Errors excepted. VERSION 12. 10. 2018

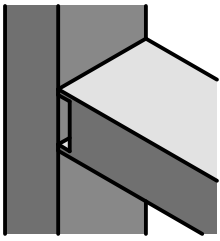

Montageanleitung/Construction Manual

RICON® 80/40 EA - A2

Art. Nr. K372

Einzelanschluss
single connection

Pfosten-Riegelverbindung
post and latch connection

Vorbohrungen im Riegel /
pre-drilling on latch

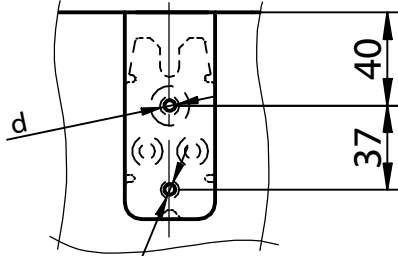

Nadelholz: d...Ø 5mm, 30mm tief vorbohren
Softwood: d...Ø 5mm, 30mm deep predrilling
Laubholz: d...Ø 6mm, 75mm tief vorbohren
Hardwood: d...Ø 6mm, 75mm deep predrilling

Vorbohrungen im Pfosten /
pre-drilling on post

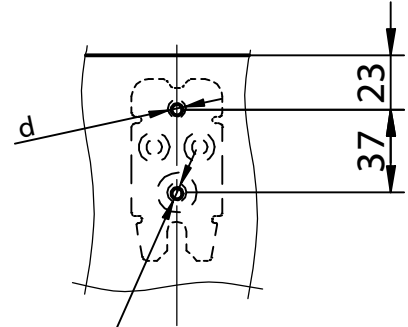

Nadelholz: d...Ø 5mm, 30mm tief vorbohren
Softwood: d...Ø 5mm, 30mm deep predrilling
Laubholz: d...Ø 6mm, 45mm tief vorbohren
Hardwood: d...Ø 6mm, 45mm deep predrilling

Verschraubung im Riegel /
installing on latch

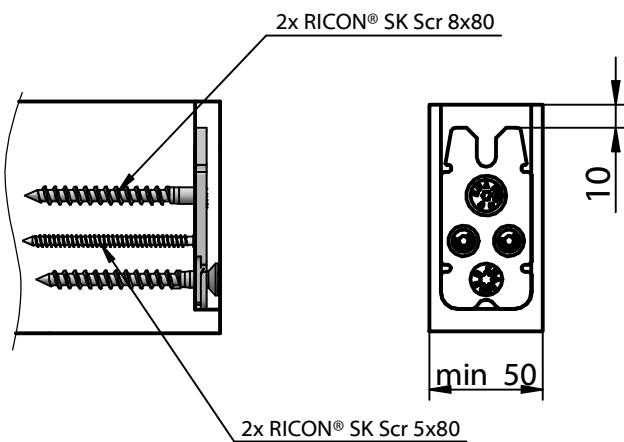

Verschraubung im Pfosten /
installing on post

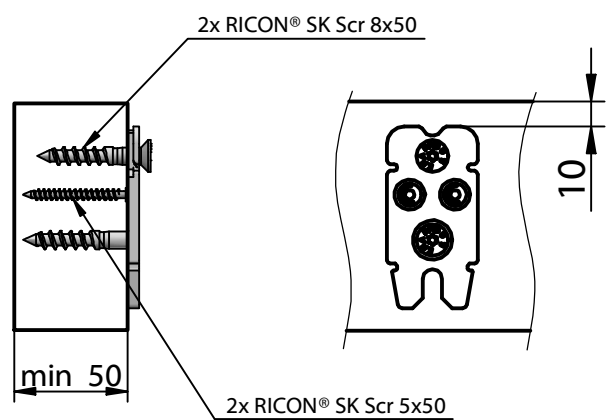

Justierbare Halteschraube /
screw depth adjustable

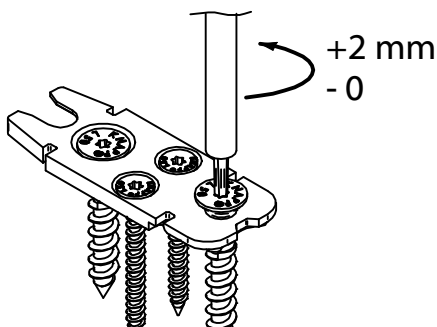

Sperrbügel einlegen /
installing locking clip

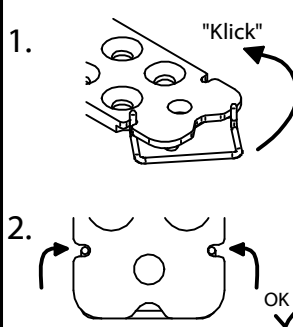

Sperrbügel lösen /
removing locking clip

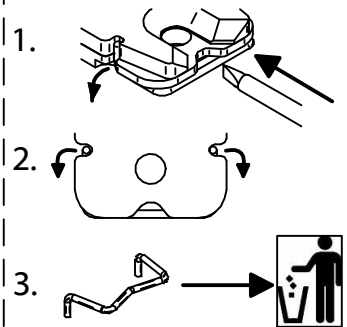

Diese Zeichnung ist Eigentum der Knapp GmbH.

© Knapp GmbH. Alle Maße in mm - Irrtümer, Druckfehler und Änderungen vorbehalten / all measures in mm - Errors excepted. VERSION 12.10.2018

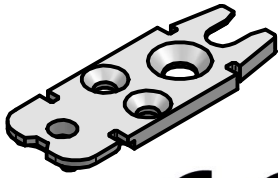

ETA-10/0189

Montageanleitung/Construction Manual

RICON® 80/40 - A2

Haupt- Nebenträgerverbindung in Edelstahl
mit Bauzulassung (EU)

main girder - joist connection in stainless steel
with construction supervisory approval (EU)

RICON® 80/40

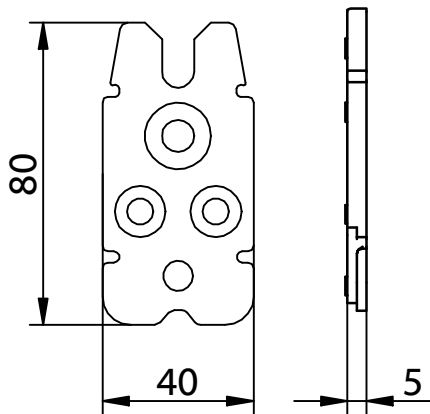

RICON® SK Scr 8x80

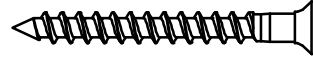

RICON® SK Scr 8x50



RICON® SK Scr 5x80

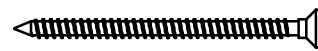

RICON® SK Scr 5x50



RICON® Sperrbügel / locking clip

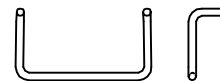

**Einzelanschluss
single connection**

**Haupt-Nebenträgerverbindung
main girder - joist connection**

Hauptträger Fräsbild /Milled edge main girder

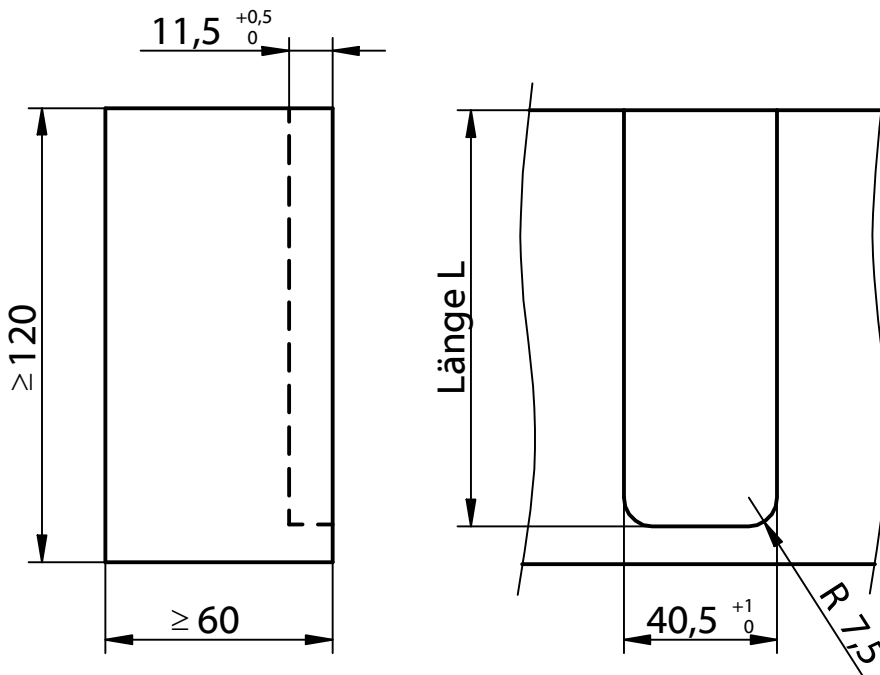

Ausfräslänge L aus dem Hauptträger in Abhängigkeit der Nebenträgerhöhe HN /
Rebate length for main girder in reference of the height HN of the joist:

Höhe / Height HN [mm]	Länge/ Length L [mm]
120	110
140	130
160	140

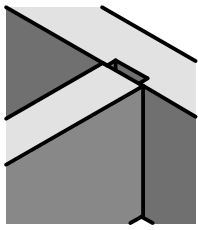

RICON® 80/40 EA - A2

Art. Nr. K372

Einzelanschluss
single connection

Haupt-Nebenträger Verbindung
main girder - joist connection

Vorbohrungen im Hauptträger /
pre-drilling on main girder

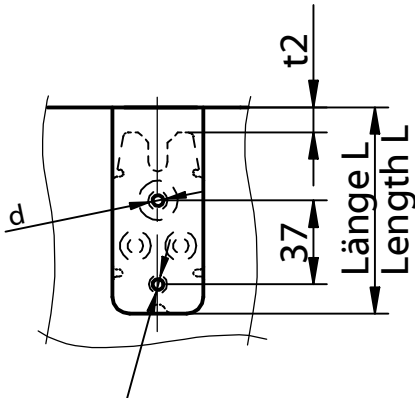

Nadelholz: d...Ø 5mm, 30mm tief vorbohren
Softwood: d...Ø 5mm, 30mm deep predrilling
Laubholz: d...Ø 6mm, 45mm tief vorbohren
Hardwood: d...Ø 6mm, 45mm deep predrilling

Vorbohrungen im Nebenträger /
pre-drilling on joist

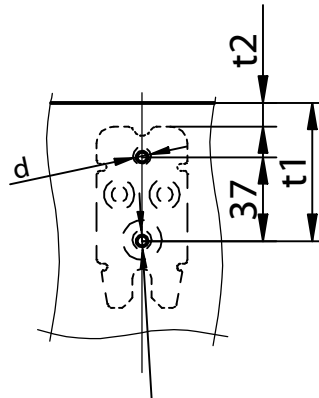

Nadelholz: d...Ø 5mm, 30mm tief vorbohren
Softwood: d...Ø 5mm, 30mm deep predrilling
Laubholz: d...Ø 6mm, 75mm tief vorbohren
Hardwood: d...Ø 6mm, 75mm deep predrilling

Einbohrmaße t1 und Abstandsmaß t2 in
Abhängigkeit der Nebenträgerhöhe HN/
Bore measure t1 and distance t2 for joist in
reference to the height HN of the joist

Höhe / Height HN [mm]	Abstand/ Distance t1 [mm]	Abstand/ Distance t2 [mm]
120	80	30
140	100	50
160	110	60

Verschraubung im Hauptträger /
pre-drilling on main girder

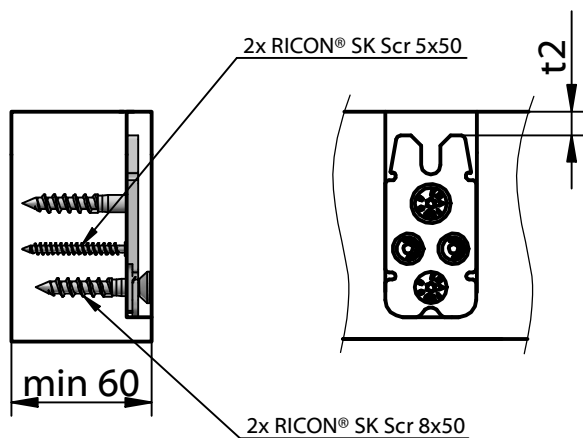

Verschraubung im Nebenträger /
pre-drilling on joist

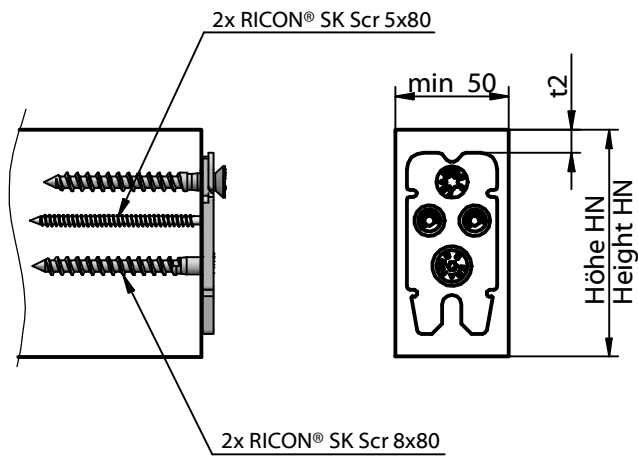

Justierbare Halteschraube /
screw depth adjustable

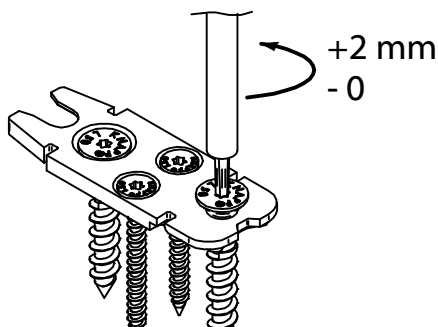

Sperrbügel einlegen /
installing locking clip

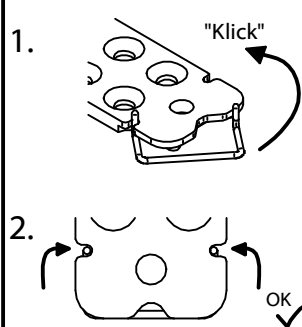

Sperrbügel lösen /
removing locking clip

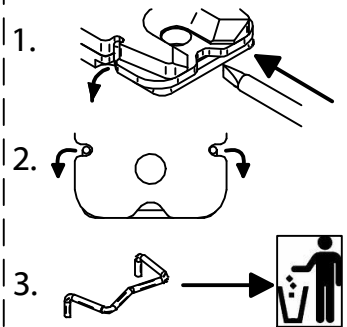

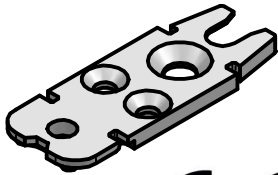

ETA-10/0189

Notice de montage/Construction Manual

RICON® 80/40 - A2

Connecteur inox pour jonctions poteau - traverse
avec agrément technique (ETE)

post and latch connection in stainless steel
with construction supervisory approval (EU)

RICON® 80/40

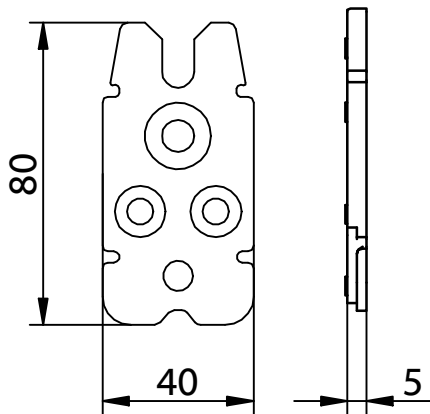

Vis RICON® TF 8x80



Vis RICON® TF 8x50



Vis RICON® TF 5x80

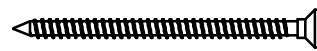

Vis RICON® TF 5x50



Goupille de verrouillage / stirrup

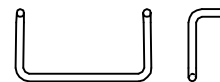

**Assemblage simple
single connection**

**Assemblage poteau - traverse
post and latch connection**

Détails du fraisage traverse /
Milled edge latch

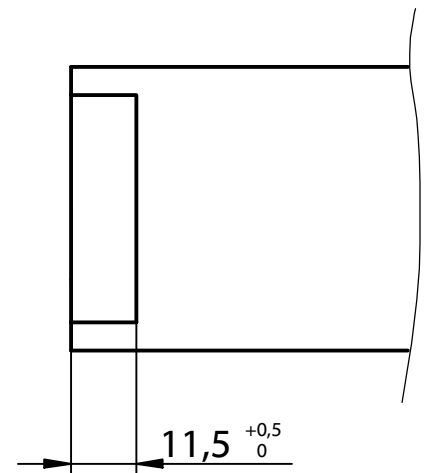
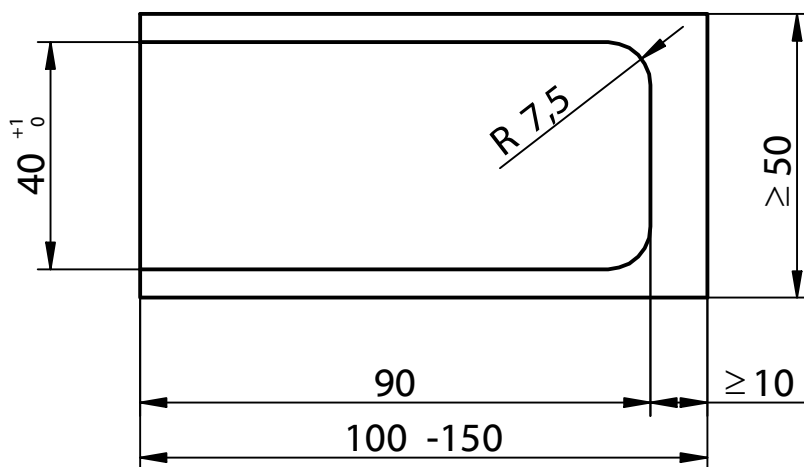

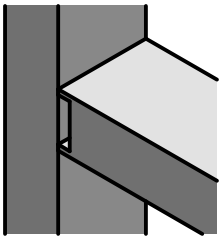

Notice de montage/Construction Manual

RICON® 80/40 EA - A2

Réf. K372

**Assemblage simple
single connection**

**Assemblages poteau - traverse
post and latch connection**

Détail du perçage sur la traverse /
drilling template for latch

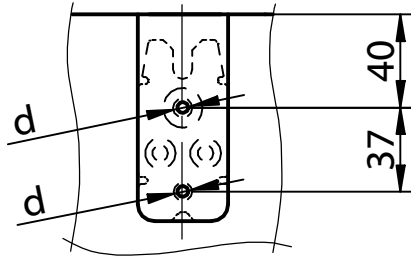

Résineux: pré-percer d...Ø 5mm, prof. 30mm
Softwood: d...Ø 5mm, 30mm deep predrilling
Feuillus: pré-percer d...Ø 6mm, prof. 75mm
Hardwood: d...Ø 6mm, 75mm deep predrilling

Détail du perçage sur le poteau /
drilling template for post

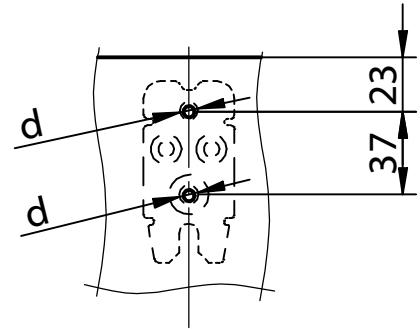

Résineux: pré-percer d...Ø 5mm, prof. 30mm
Softwood: d...Ø 5mm, 30mm deep predrilling
Feuillus: pré-percer d...Ø 6mm, prof. 45mm
Hardwood: d...Ø 6mm, 45mm deep predrilling

Détail du vissage sur la traverse /
screw template for latch

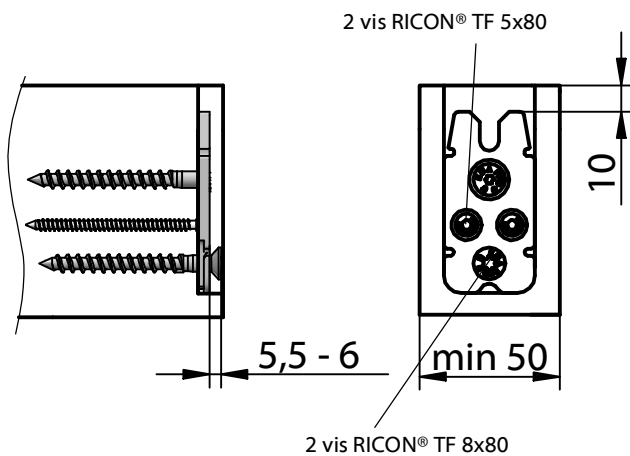

Détail du vissage sur le poteau /
screw template for post

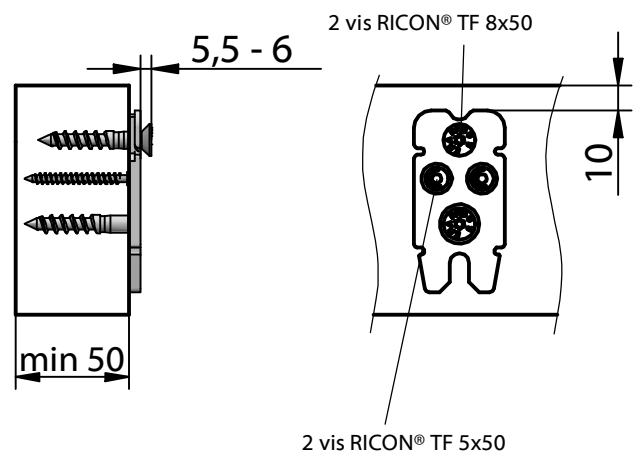

Régler la vis d'accroche /
screw position adjustment

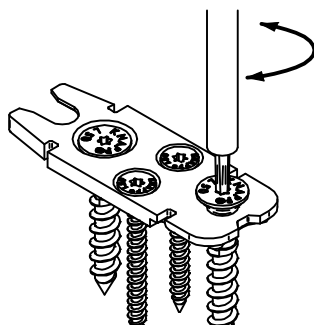

Mettre la goupille en
place / assemble stirrup

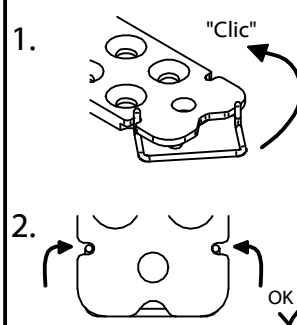

Déverrouiller la
goupille / remove stirrup

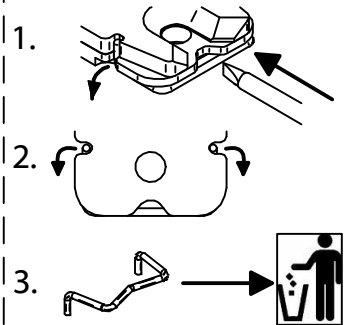

Ces dessins sont la propriété de Knapp GmbH.

© Knapp GmbH. Toutes dimensions en mm - sauf erreurs, fautes d'impression ou modifications techniques / all measures in mm - Errors excepted. VERSION 24.05.2018

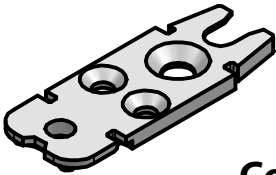

RICON® 80/40 - A2

Connecteur inox pour jonctions poutres principale - secondaire
 avec agrément technique (ETE)
main girder - joist connection in stainless steel
 with construction supervisory approval (EU)



RICON® 80/40

Vis RICON® TF 8x80

Vis RICON® TF 8x50

Vis RICON® TF 5x80

Vis RICON® TF 5x50

Goupille de verrouillage / stirrup

Assemblage simple
single connection

Assemblage poutres principale - secondaire
main girder - joist connection

Détails du fraisage poutre principale / Milled edge main girder

Longueur de fraisage L sur poutre principale en relation avec la hauteur de la poutre secondaire HN /
 Rebate length for main girder in reference of the height HN of the joist:

Hauteur / Height HN [mm]	Longueur / Length L [mm]
120	110
140	130
160	140

Ces dessins sont la propriété de Knapp GmbH.

© Knapp GmbH. Toutes dimensions en mm - sauf erreurs, fautes d'impression ou modifications techniques / all measures in mm - Errors excepted. VERSION 24.05.2018

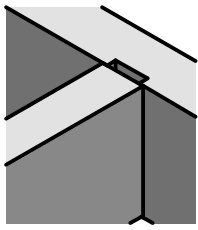

Notice de montage/Construction Manual

RICON® 80/40 EA - A2

Réf. K372

**Assemblage simple
single connection**

**Assemblages poutres principale - secondaire
main girder - joist connection**

Détail du perçage sur la poutre principale /
drilling template for main girder

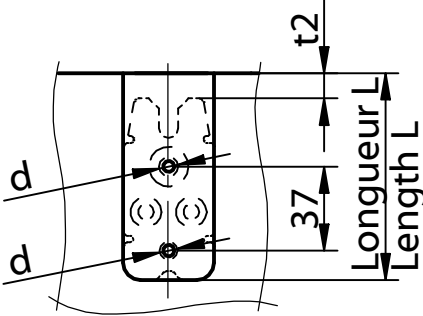

Résineux: pré-percer d...Ø 5mm, prof. 30mm
Softwood: d...Ø 5mm, 30mm deep predrilling
Feuillus: pré-percer d...Ø 6mm, prof. 75mm
Hardwood: d...Ø 6mm, 75mm deep predrilling

Détail du perçage sur la poutre secondaire /
drilling template for joist

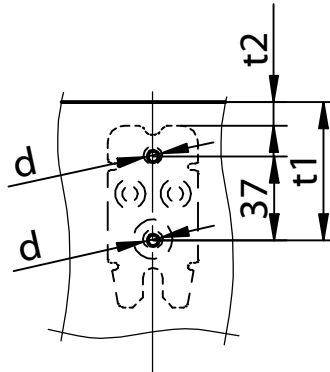

Distance de perçage t1 et t2 en relation avec la poutre secondaire HN/
Bore measure t1 and distance t2 for joist in reference to the height HN of the joist

Hauteur / Height HN [mm]	Distance / Distance t1 [mm]	Distance / Distance t2 [mm]
120	80	30
140	100	50
160	110	60

Résineux: pré-percer d...Ø 5mm, prof. 30mm
Softwood: d...Ø 5mm, 30mm deep predrilling
Feuillus: pré-percer d...Ø 6mm, prof. 45mm
Hardwood: d...Ø 6mm, 45mm deep predrilling

Détail du vissage sur la poutre principale /
screw template for main girder

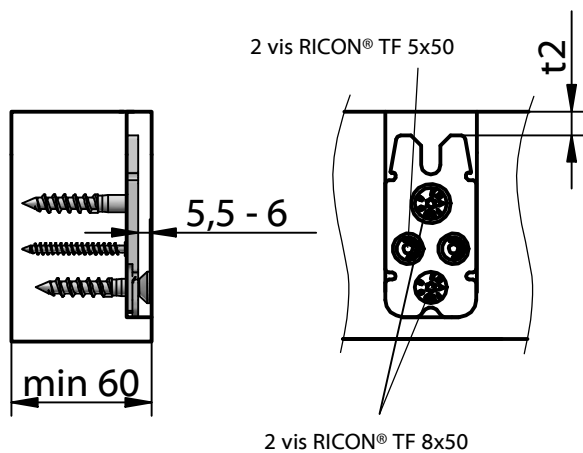

Détail du vissage sur la poutre secondaire /
screw template for joist

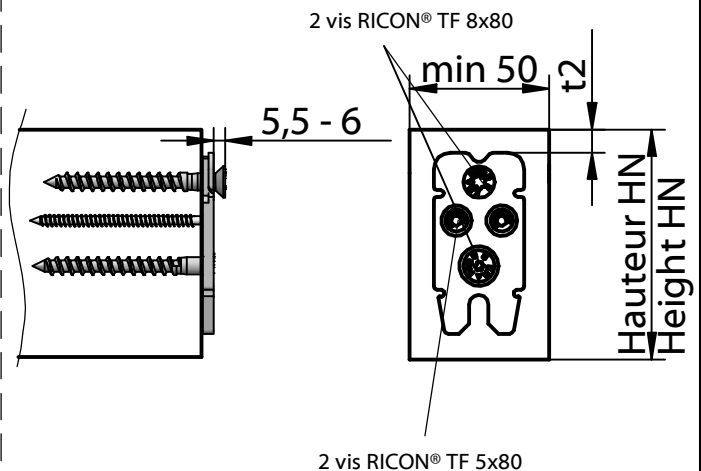

Régler la vis d'accroche /
screw position adjustment

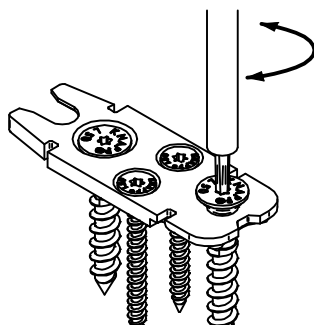

Mettre la goupille en place /
assemble stirrup

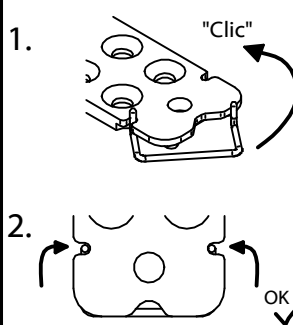

Déverrouiller la goupille /
remove stirrup

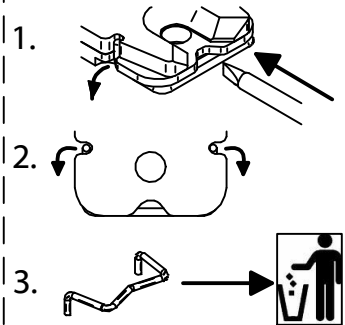

Ces dessins sont la propriété de Knapp GmbH.

© Knapp GmbH. Toutes dimensions en mm - sauf erreurs, fautes d'impression ou modifications techniques / all measures in mm - Errors excepted. VERSION 24.05.2018