

Art. Nr. K134

Ausfräsung im Haupt- u. Nebenträger

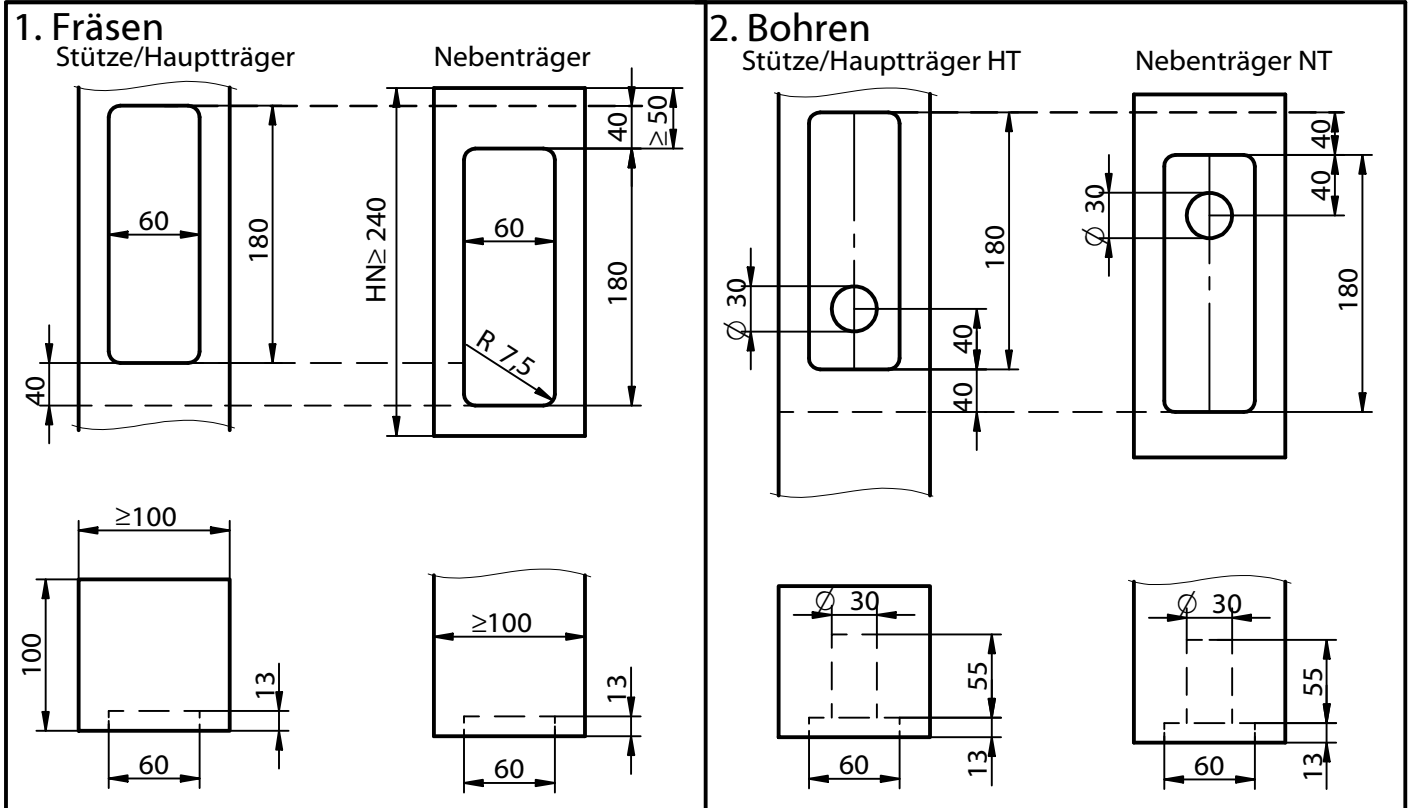

3. Verschrauben

1. Verbinder in Ausfräsung einlegen

GK M12

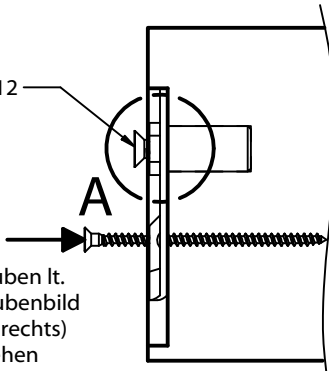

2. Schrauben lt. Schraubenbild (siehe rechts) eindrehen

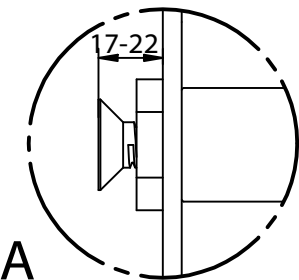

Befestigung im Nebenträger NT und Hauptträger HT/Stütze

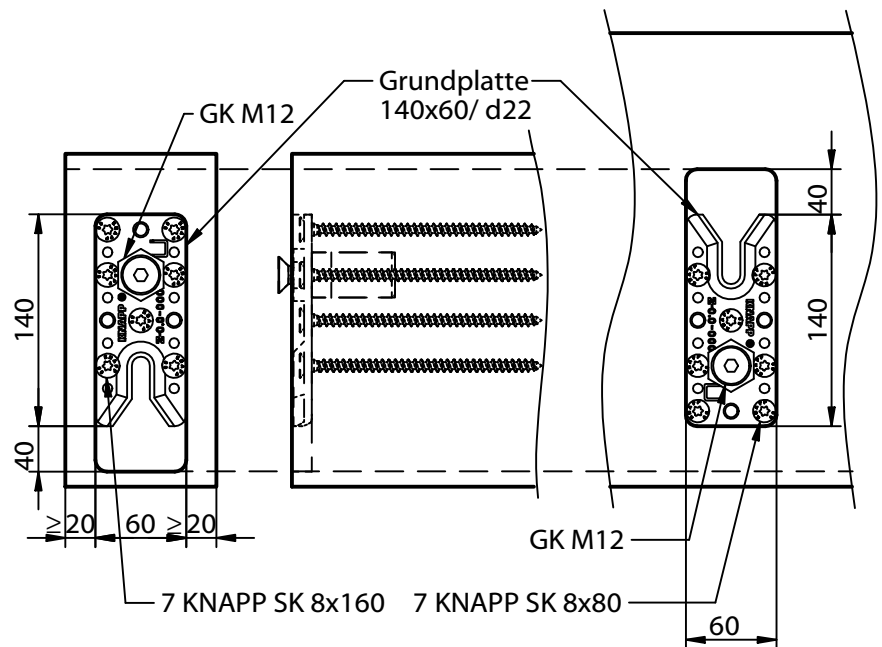

Diese Zeichnung ist Eigentum der Knapp GmbH.

© Knapp GmbH. - Alle Maße in mm - Irrtümer, Druckfehler und Änderungen vorbehalten. VERSION 02 10.09.2012

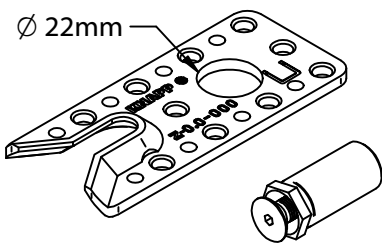

RICON® S 140/60 GK22

Gefederter Kragenbolzen



Art. Nr. K134

Ausfräsung im Haupt- u. Nebenträger

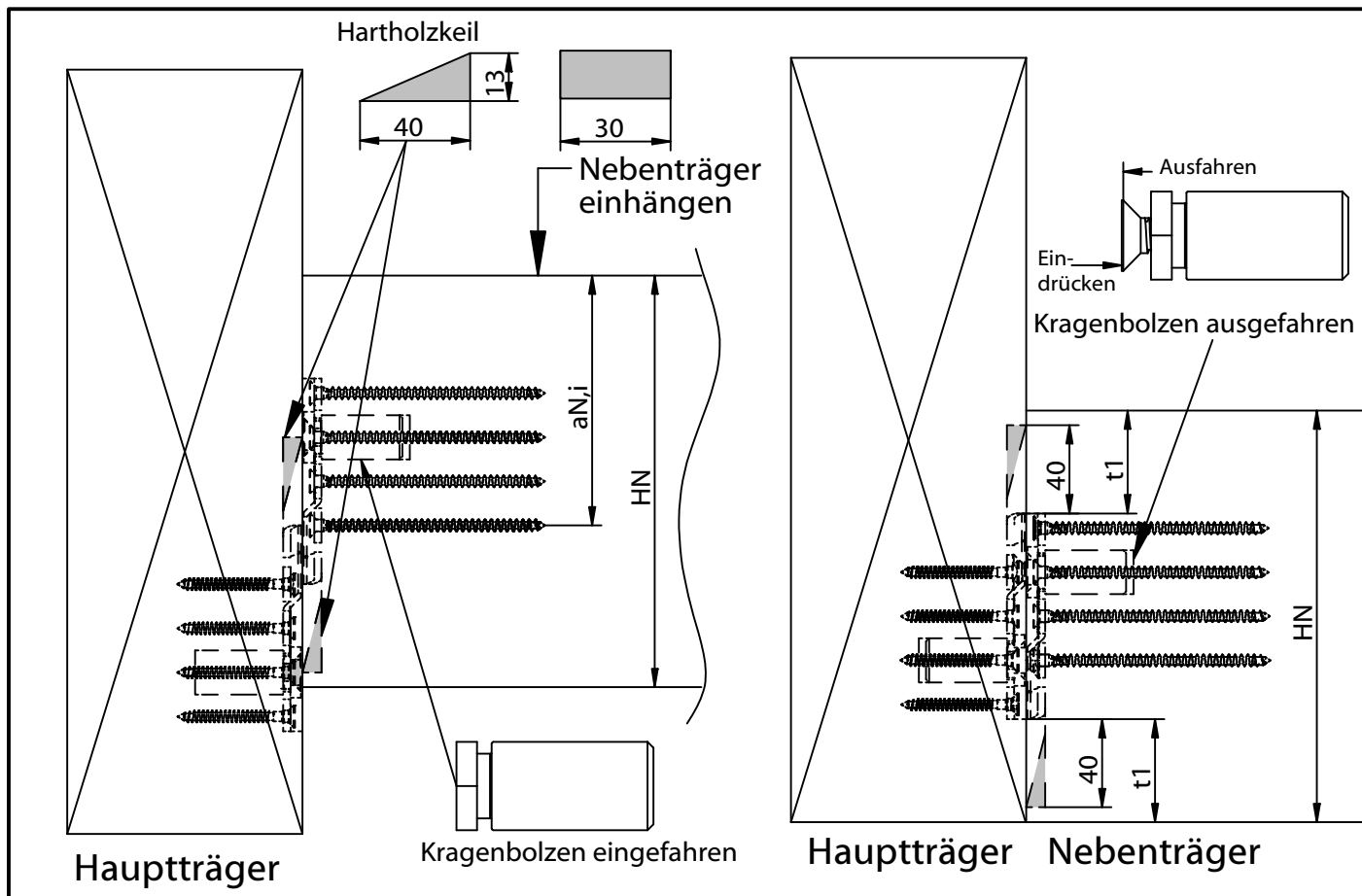

Nebenträger- höhe	Randabstand t_1 in Abhängigkeit der Nebenträgerhöhe H_N			
	RICON S 140x60	RICON S 170x60	RICON S 200x60	RICON S 230x60
H_N	Abstand t_1	Abstand t_1	Abstand t_1	Abstand t_1
[mm]	[mm]	[mm]	[mm]	[mm]
240	50	-	-	-
260	60	-	-	-
280	-	55	-	-
300	-	-	50	-
320	-	-	60	-
340	-	-	-	55
360	-	-	-	65

Wichtiger Hinweis:

Nach Bauzulassung Z-9.1-698 (siehe auch DIN 1052, 11.4.3 bzw. EN 1995-1-1 und NAD) muss bei einem Verhältnis $aN_i / HN \leq 0,7$ ein Querkugnachweis vom Statiker durchgeführt werden. Eine Querkugverstärkung des Nebenträgers mit Vollgewindeschrauben ist möglich.

Diese Zeichnung ist Eigentum der Knapp GmbH.

© Knapp GmbH. Alle Maße in mm - Irrtümer, Druckfehler und Änderungen vorbehalten. VERSION 02 10.09.2012

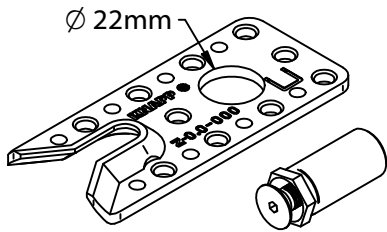

Construction Manual RICON® S 140/60 GK22

Spring retaining screw collar bolt



Art. No. K134

Machined edge of the joint and header

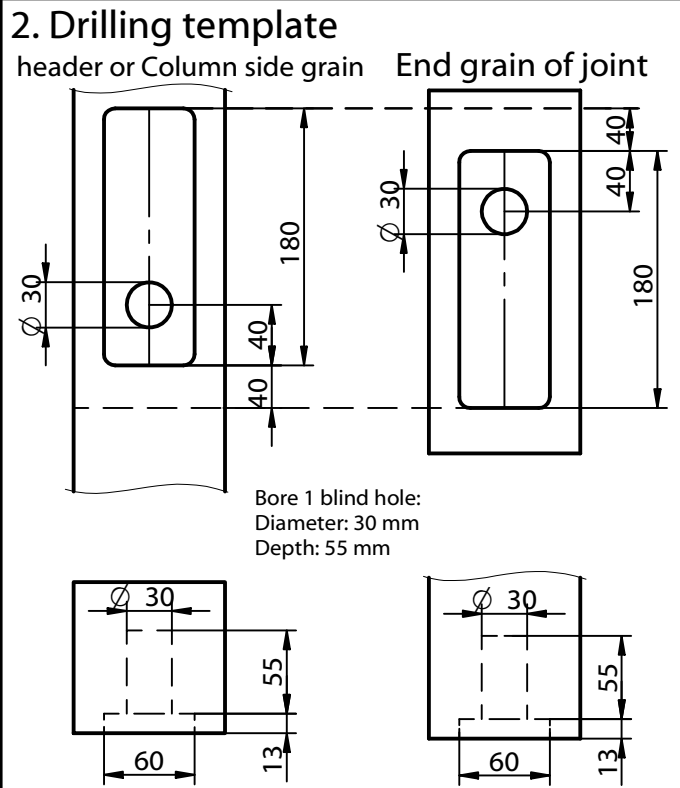
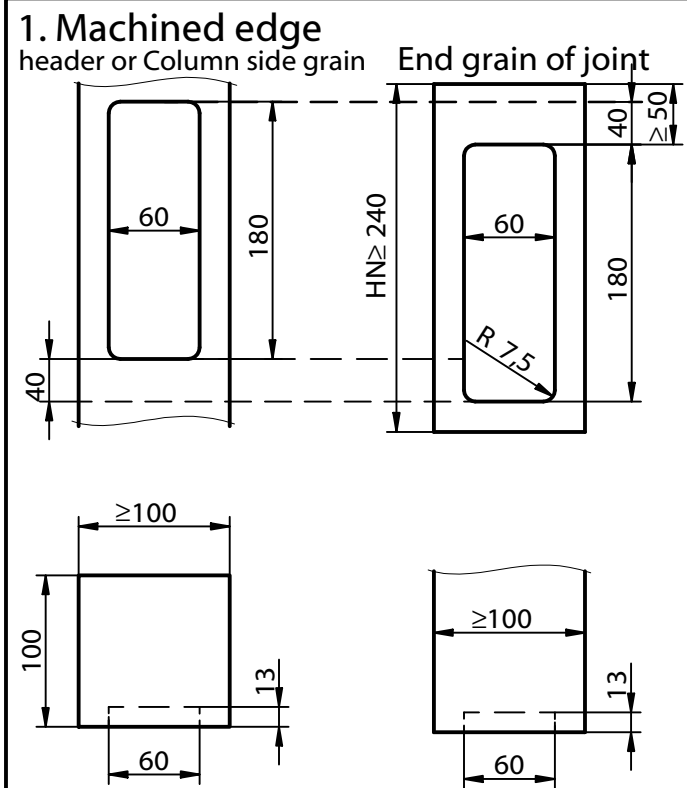

3. Screwing:

1. Fasten socket head screw with coupling nut and jam nut to the connector

2. Screw on the connector with full thread CS-screws in the holes provided

3. Screw on the connector with KNAPP CS-screws according to the screw picture

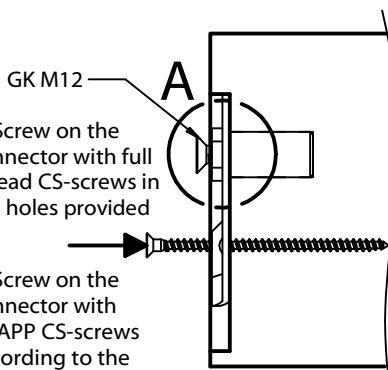

Screw picture for joint and header or column

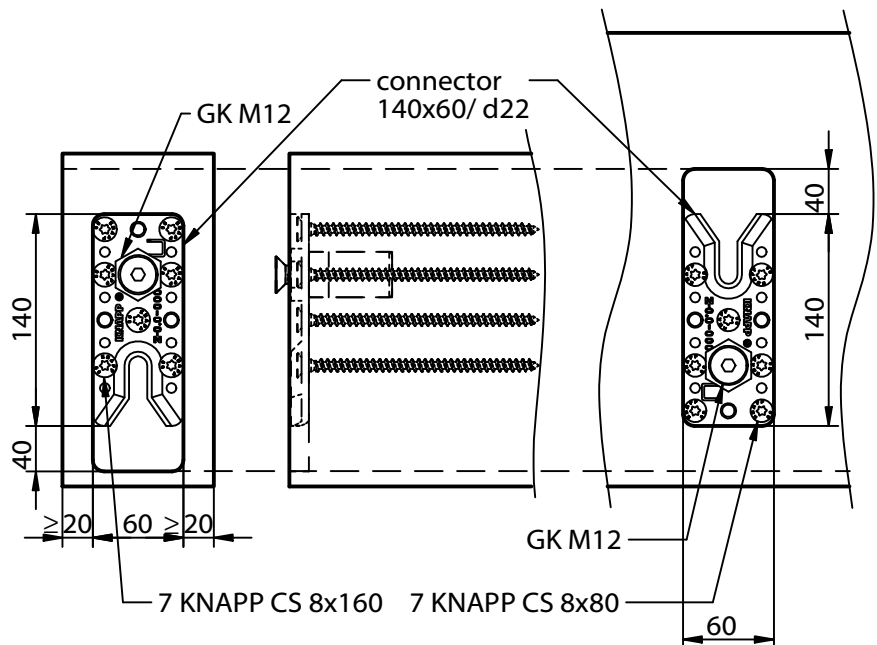

This drawing is the exclusive property of Knapp GmbH.

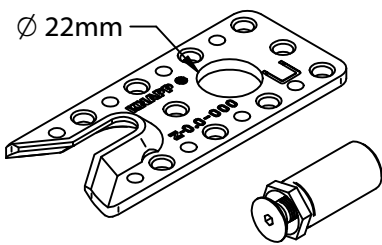

Art. No. K134

Machined edge of the joint and header

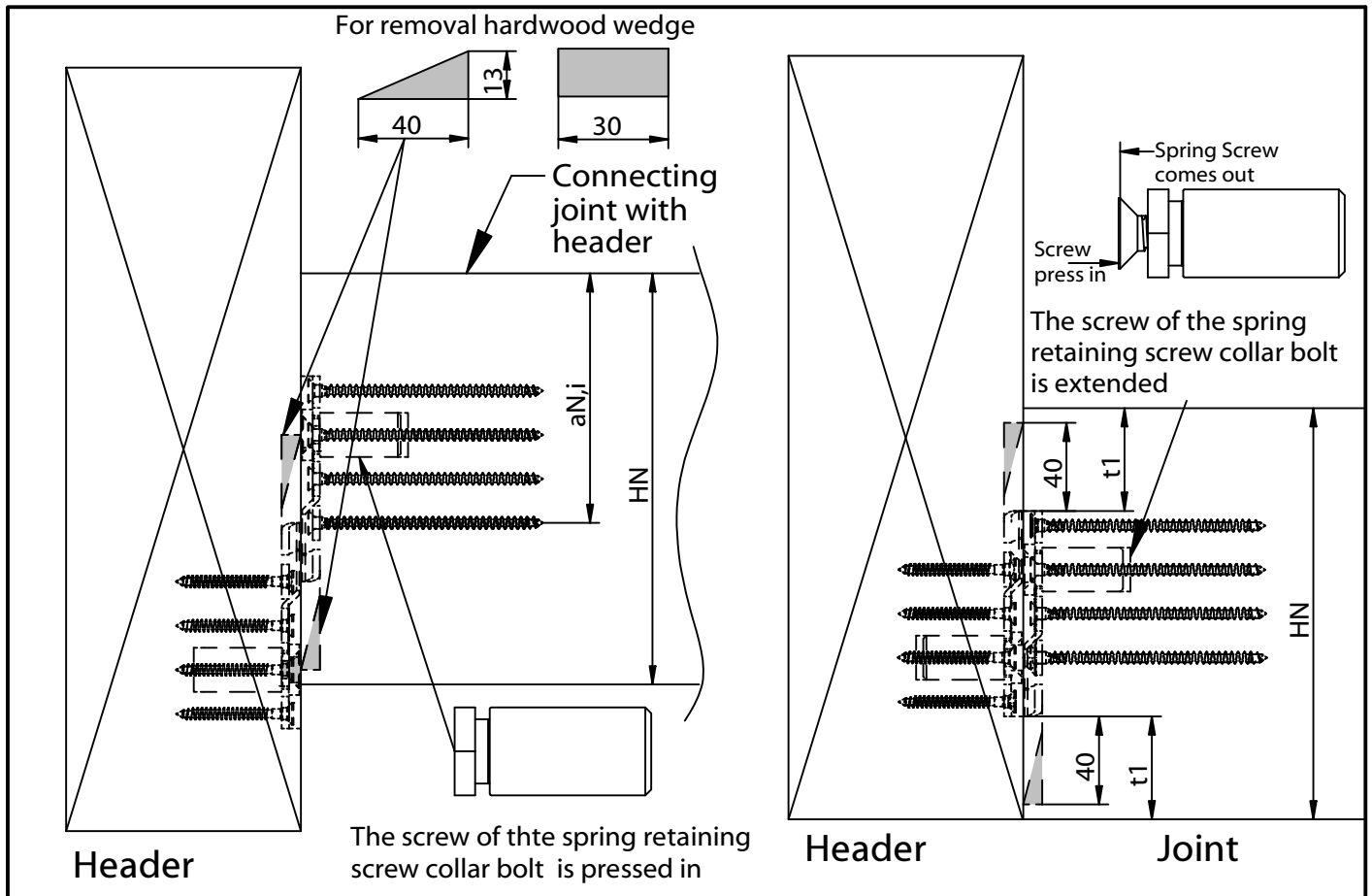

Header

The screw of the spring retaining screw collar bolt is pressed in

Header

Joint

Secondary beam height	Edge distance t_1 in reference of height H_N of secondary beam			
	RICON S 140x60	RICON S 170x60	RICON S 200x60	RICON S 230x60
H_N	Distance t_1	Distance t_1	Distance t_1	Distance t_1
[mm]	[mm]	[mm]	[mm]	[mm]
240	50	-	-	-
260	60	-	-	-
280	-	55	-	-
300	-	-	50	-
320	-	-	60	-
340	-	-	-	55
360	-	-	-	65

Important Information:

Provided that $aN_i > 0,7 H_N$ or the splitting of the ancillary load bearing element is prevented by a transverse tension reinforcement element with self-sinking full-thread screws in accordance with general construction supervisory approval, the proof of transverse tension on ancillary load-bearing members may be waived. Please contact a structural engineer, who has to proof the tensile strength perpendicular to the grain (see ConstructionSupervisory Approval Z-9.1-698 or EN 1995-1-1 and NAD).

This drawing is the exclusive property of Knapp GmbH.

© Knapp GmbH. All measures in mm - Errors excepted. VERSION 02 10.09.2012

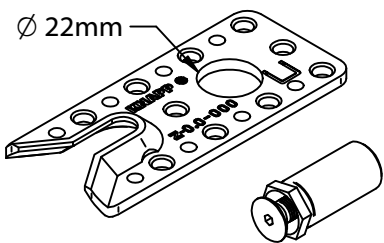

RICON® S 140/60 GK22

Insert à ressort avec vis d'accroche



ETA-10/0189

Réf. K134

Encastrement sur la poutre principale et poutre secondaire

1. Fraiser

Poutre principale / poteau

Poutre secondaire

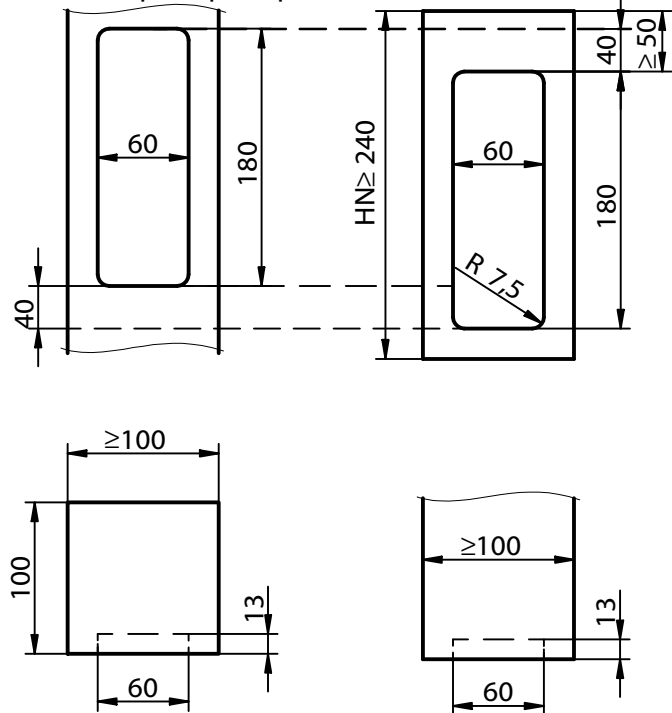

2. Percer

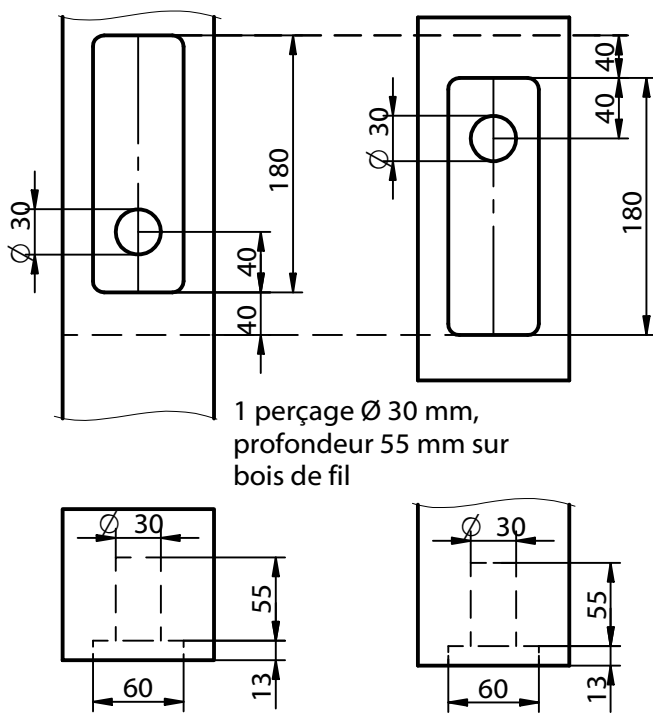

3. Visser

- Positionner la ferrure dans le fraisage et les perçages de position
- Visser les vis suivant le schéma (cf. dessins à droite)

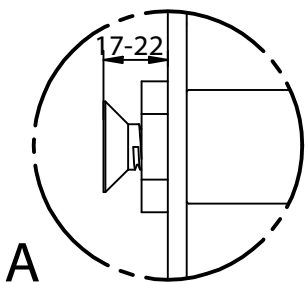
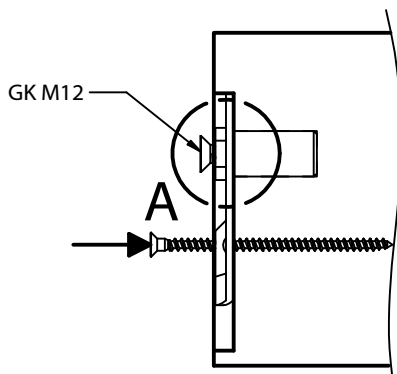

Fixation sur la poutre secondaire et principale

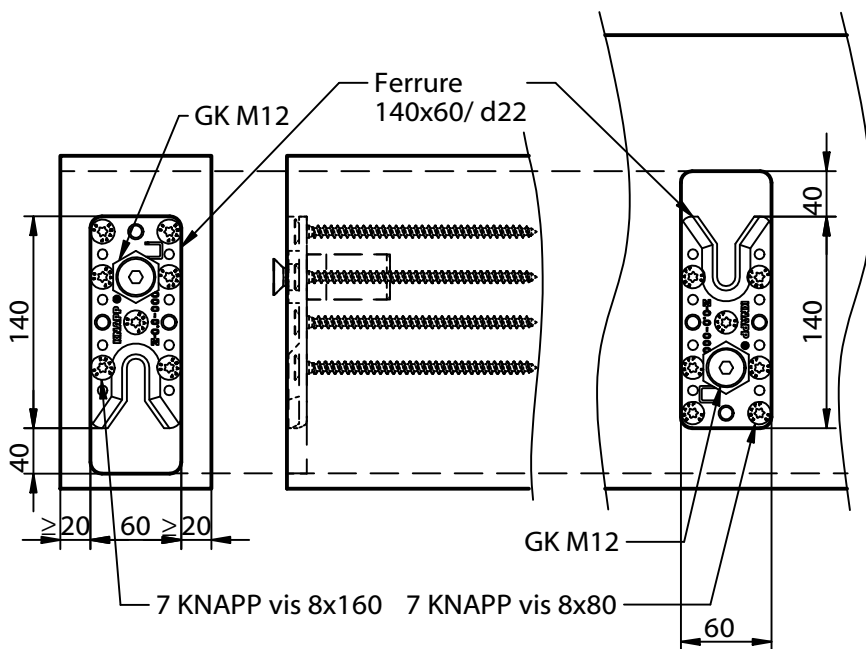

Ce dessin est la propriété de Knapp GmbH.

© Knapp GmbH. Toutes dimensions en mm - sauf erreurs, fautes d'impression ou modifications techniques. VERSION 02 10.09.2012

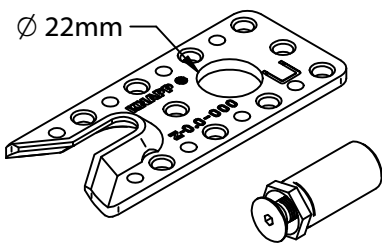

RICON® S 140/60 GK22

Insert à ressort avec vis d'accroche



ETA-10/0189

Réf. K134

Encastrement sur la poutre principale et poutre secondaire

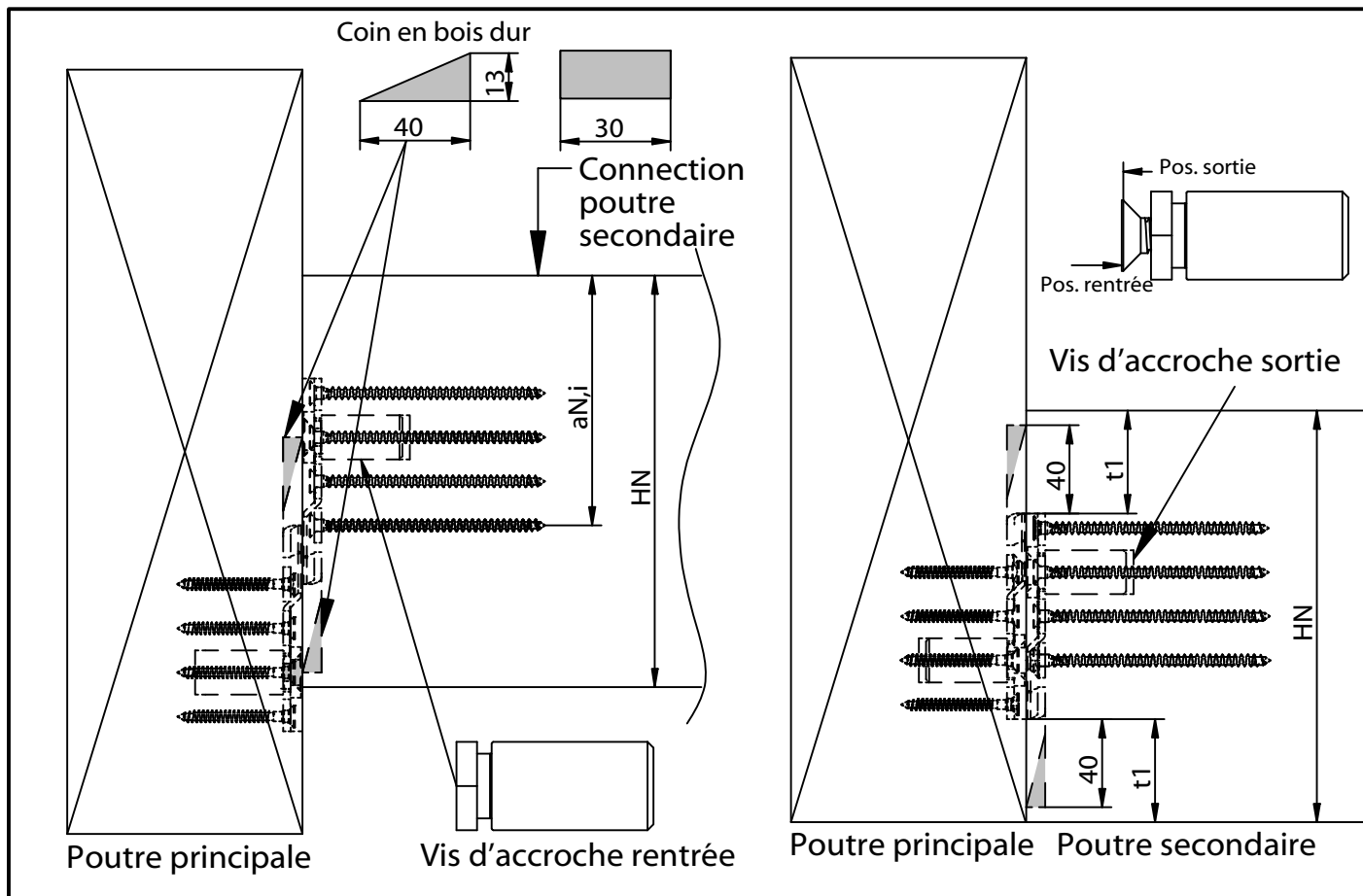

Hauteur de poutre secondaire	Distance du bord t_1 en relation avec la hauteur de la poutre secondaire H_N			
	RICON S 140x60	RICON S 170x60	RICON S 200x60	RICON S 230x60
H_N	Distance t_1	Distance t_1	Distance t_1	Distance t_1
[mm]	[mm]	[mm]	[mm]	[mm]
240	50	-	-	-
260	60	-	-	-
280	-	55	-	-
300	-	-	50	-
320	-	-	60	-
340	-	-	-	55
360	-	-	-	65

Remarque importante:

Dans le cas où la hauteur de la poutre secondaire est plus faible qu'indiqué ci-dessus, il est nécessaire de faire effectuer un calcul de contrôle de résistance statique par un ingénieur compétent. Une section plus faible peut en outre être renforcée par des vis de renfort traversant!

Le dimensionnement des vis de renfort est à déterminer par un ingénieur. (EN 1995-1-1, NAD et DIN 1052,11.4.3)

Ce dessin est la propriété de Knapp GmbH.

© Knapp GmbH. Toutes dimensions en mm - sauf erreurs, fautes d'impression ou modifications techniques. VERSION 02 10.09.2012