

Montageanleitung DUO 30 ml

Einhängeverbinder

Art.-Nr. K070

DUO 30 ml blau verzinkt

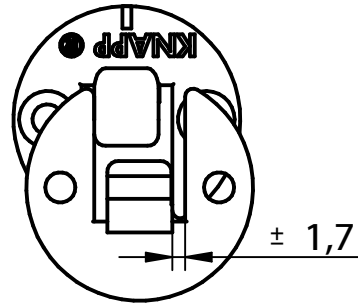
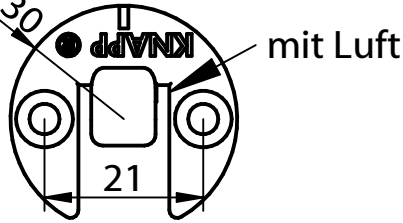
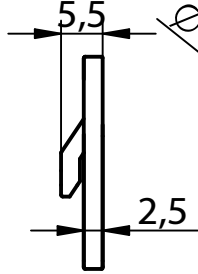

Beidseitig
Aufschrauben

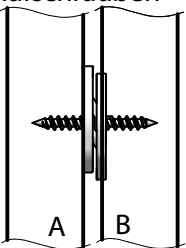

1. Aufschrauben

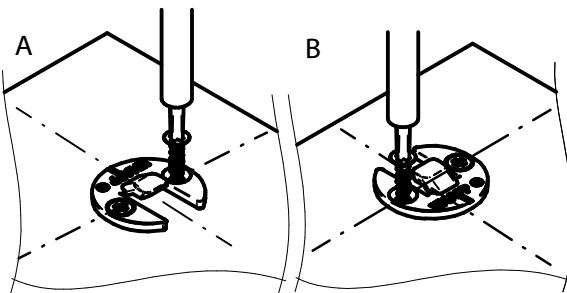

2. Einhängen

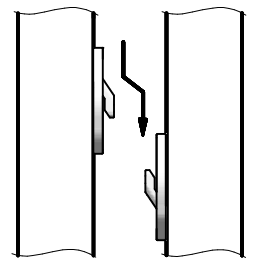

Einseitig
Einbohren

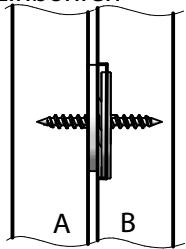

1. Bohren

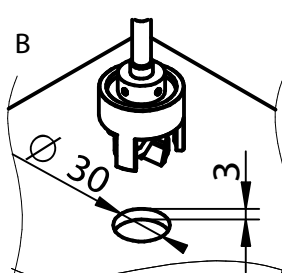

2. Übertragen

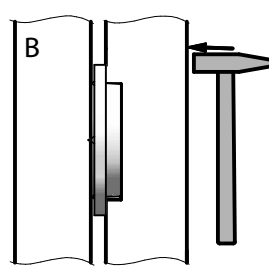

3. Einschrauben und
Einhängen

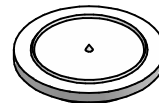
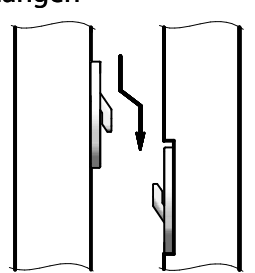

Körner K071



Körner K075

Beidseitig
Einbohren

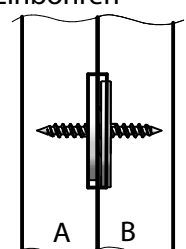

1. Bohren

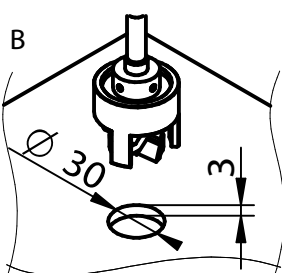

2. Übertragen

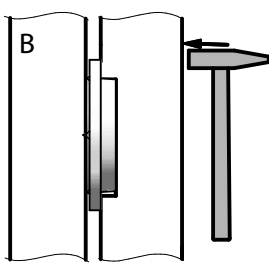

3. Bohren

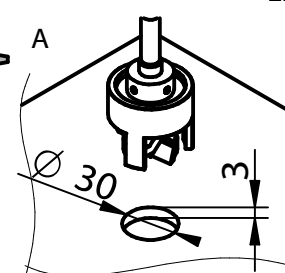

4. Einschrauben und
Einhängen

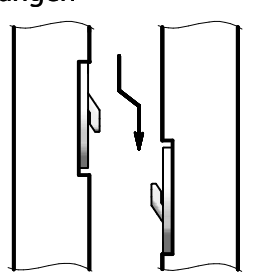

Einseitig
Ausnuten

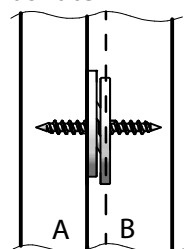

1. Nuten

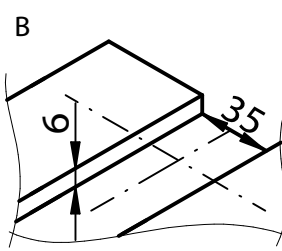

2. Übertragen

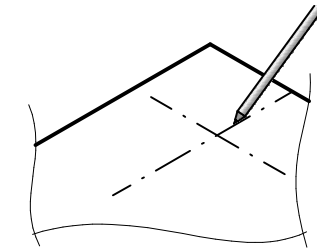

3. Einschrauben und
Einhängen

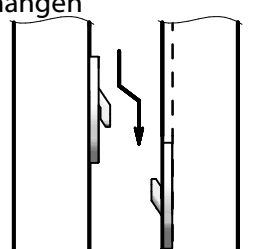

Diese Zeichnung ist Eigentum der Knapp GmbH.

© Knapp GmbH. Alle Maße in mm - Irrtümer, Druckfehler und Änderungen vorbehalten. VERSION 02 08.09.2014

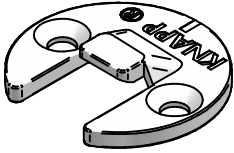

Montageanleitung DUO 30 ol

Einhängeverbinder

Art.-Nr. K074

DUO 30 ol gelb verzinkt

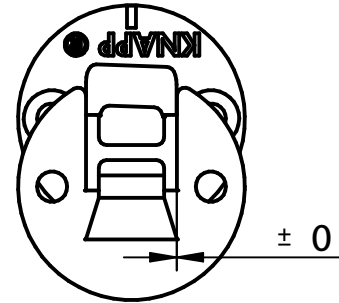
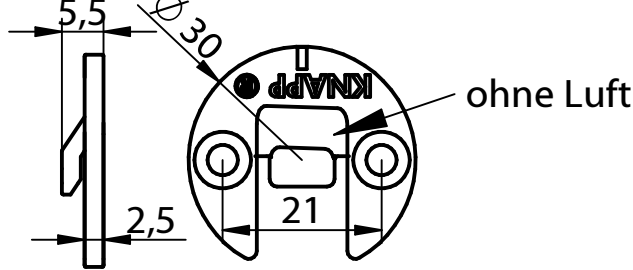

Beidseitig
Aufschrauben

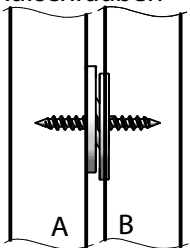

1. Aufschrauben

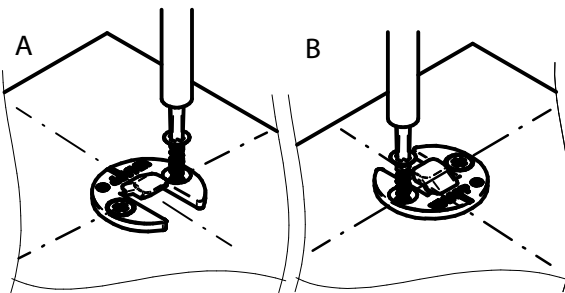

2. Einhängen

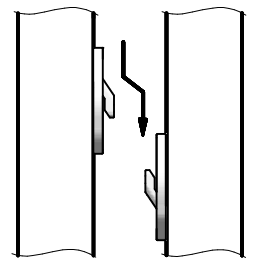

Einseitig
Einbohren

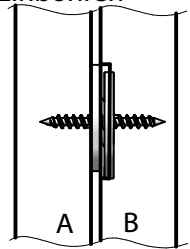

1. Bohren

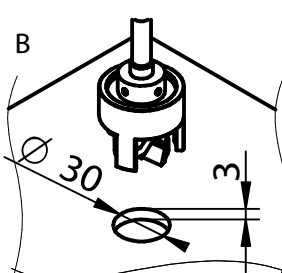

2. Übertragen

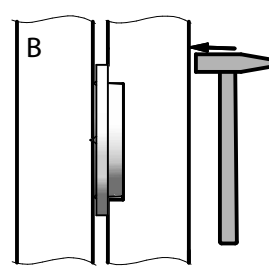

3. Einschrauben und
Einhängen

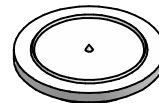
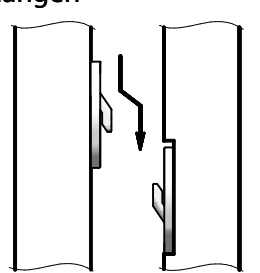

Körner K071



Körner K075

Beidseitig
Einbohren

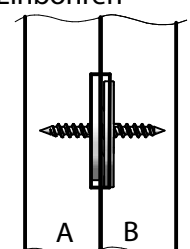

1. Bohren

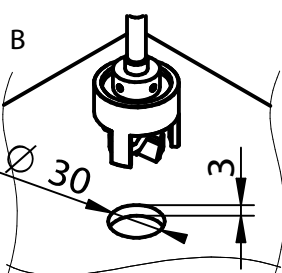

2. Übertragen

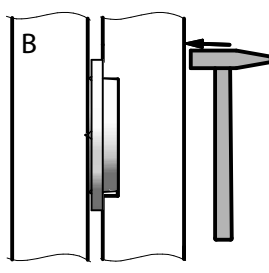

3. Bohren

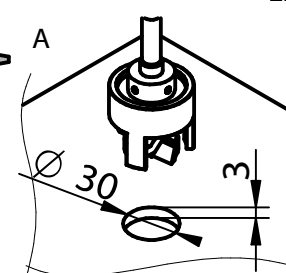

4. Einschrauben und
Einhängen

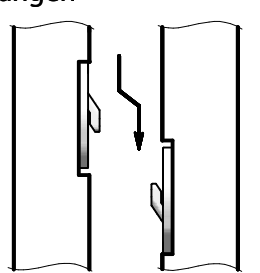

Einseitig
Ausnuten

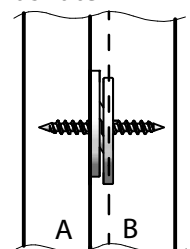

1. Nuten

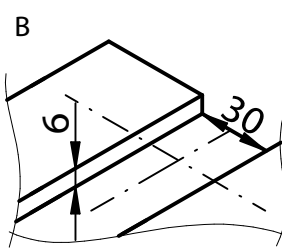

2. Übertragen

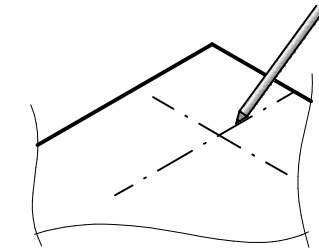

3. Einschrauben und
Einhängen

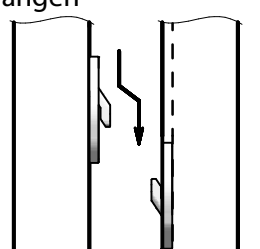

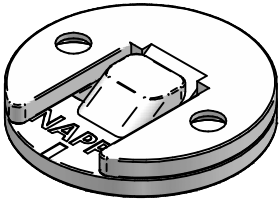

Montageanleitung

DUO 30 ml/o

Einhängeverbinder

DUO 30 ml blau verzinkt

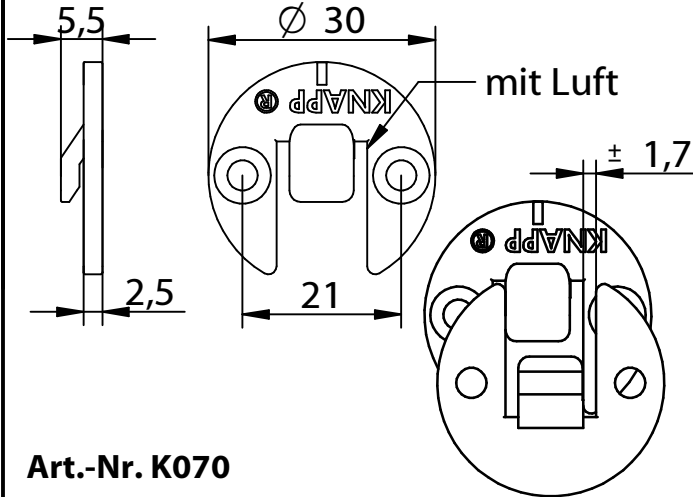

Art.-Nr. K070

DUO 30 ol gelb verzinkt

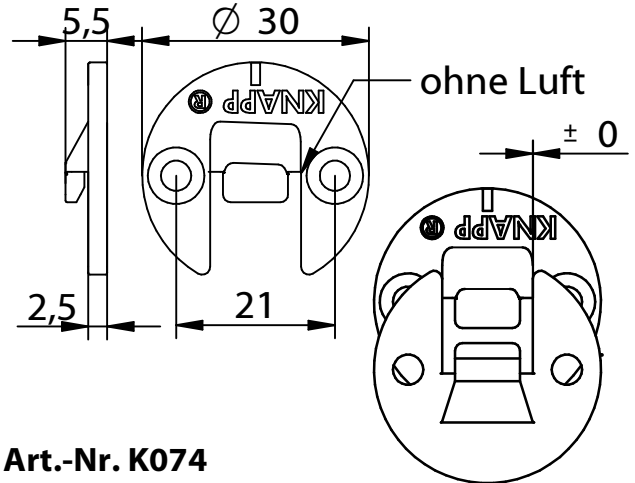

Art.-Nr. K074

1. DUO 30 auf Maß anreißen und 3 mm tief bohren

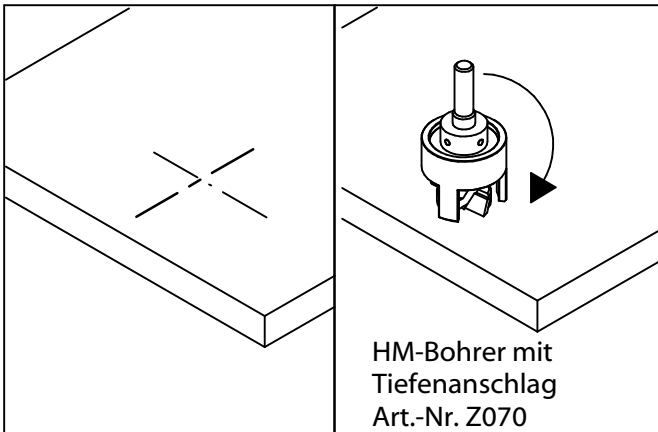

HM-Bohrer mit
Tiefenanschlag
Art.-Nr. Z070

1. Bohrschablone auf Maß einstellen und 3 mm tief bohren

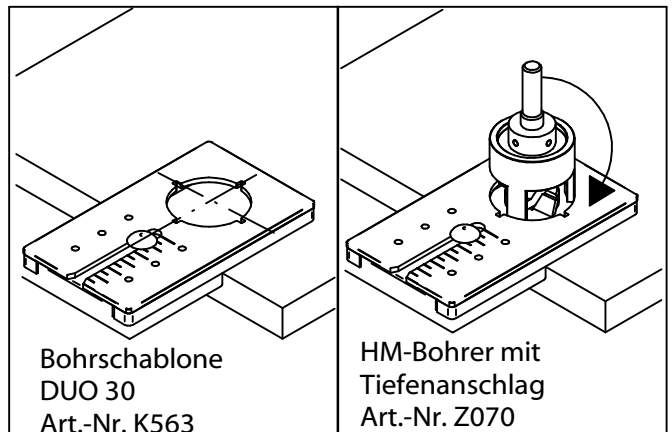

Bohrschablone
DUO 30
Art.-Nr. K563

HM-Bohrer mit
Tiefenanschlag
Art.-Nr. Z070

2. Gegenstück kornen

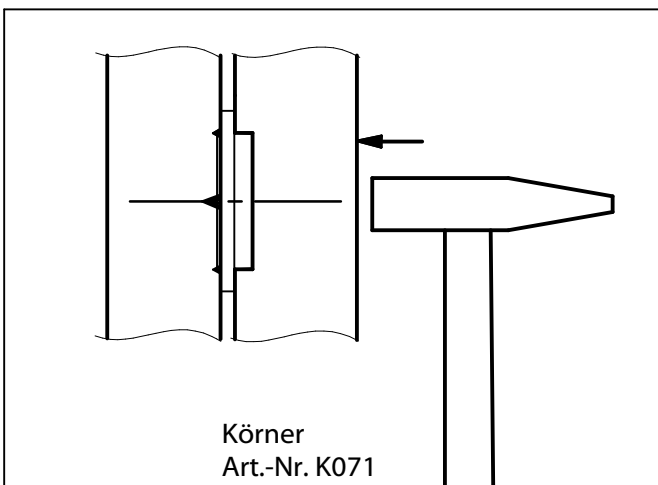

Körner
Art.-Nr. K071

3. Einschrauben und Einhängen

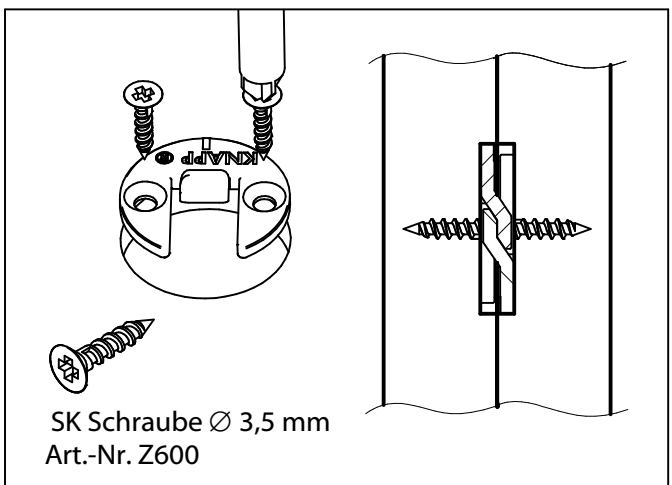

SK Schraube \varnothing 3,5 mm
Art.-Nr. Z600

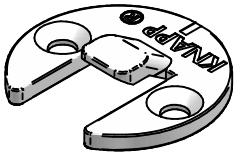

Construction Manual

DUO 30 ml

Art.-No. K070

Hook connector

DUO 30 ml blue zinc-plated

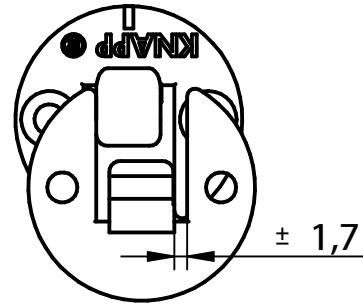
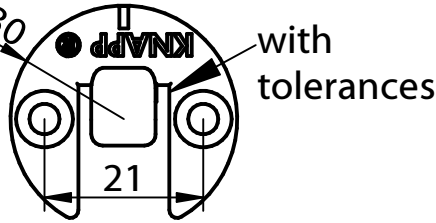
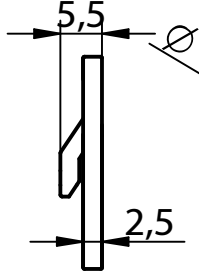

screw on both sides

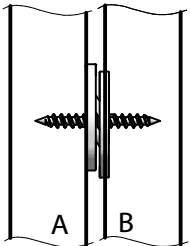

1. Screwing

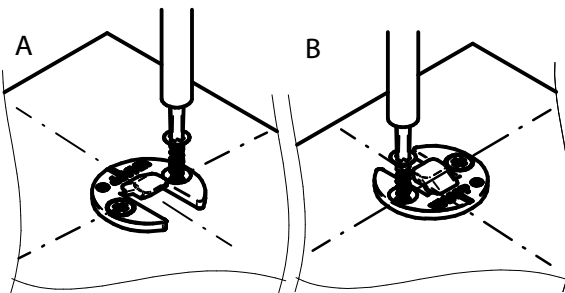

2. To connect

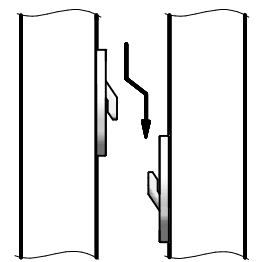

drill on one side

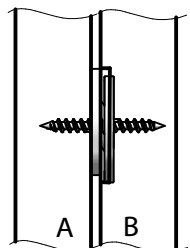

1. Drilling

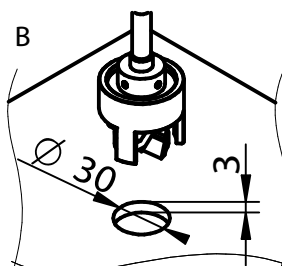

2. Copy with center punch

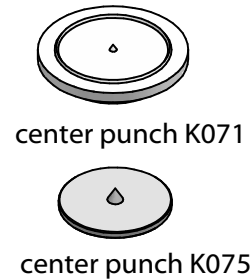
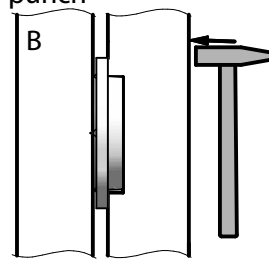

3. Screwing and connect

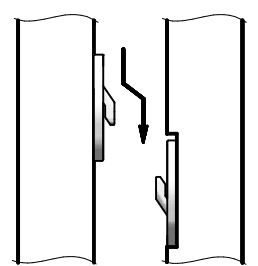

drill on both sides

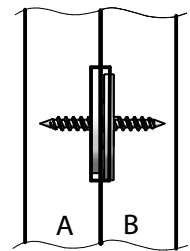

1. Drilling

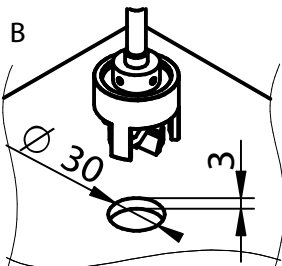

2. Copy

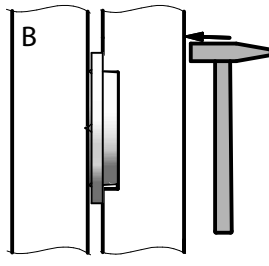

3. Drilling

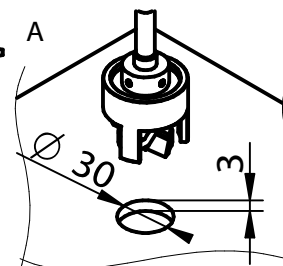

4. Screwing and connect

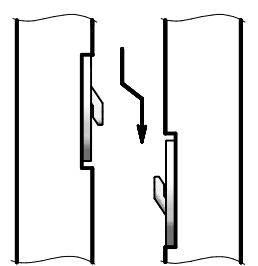

groove on one side

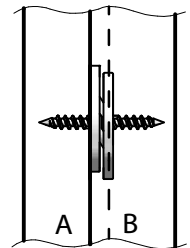

1. Grooving

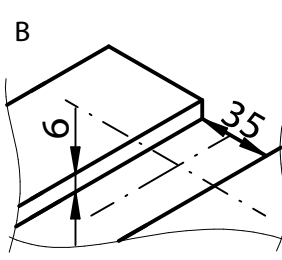

2. Copy

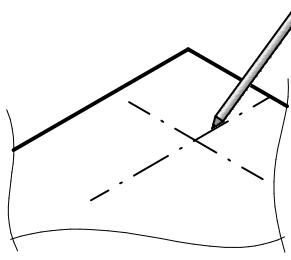

3. Screwing and connect

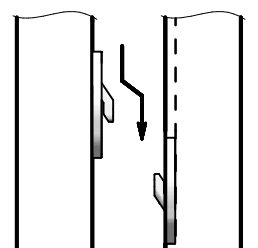

This drawing is the exclusive property of Knapp GmbH.

© Knapp GmbH. All measures in mm - Errors excepted. VERSION 02 08.09.2014

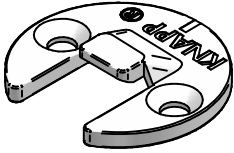

Construction Manual

DUO 30 ol

Art.-No. K074

Hook connector

DUO 30 ol yellow zinc-plated

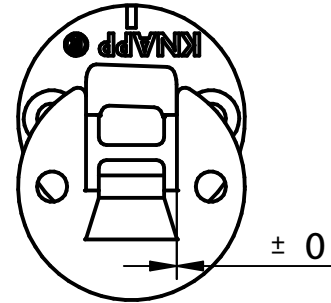
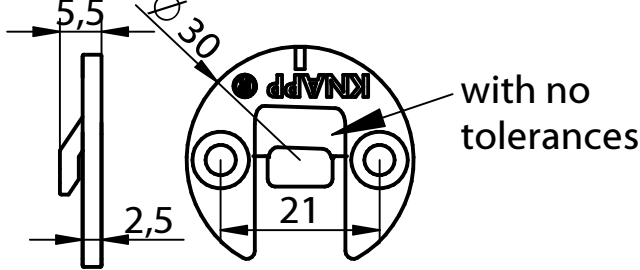

screw on both sides

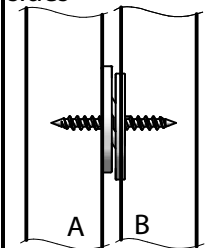

1. Screwing

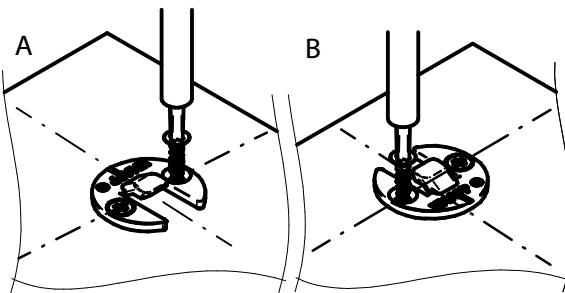

2. To connect

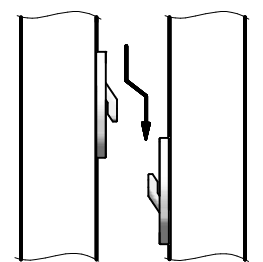

drill on one side

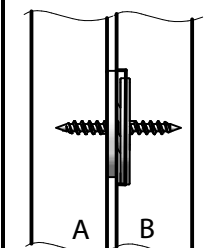

1. Drilling

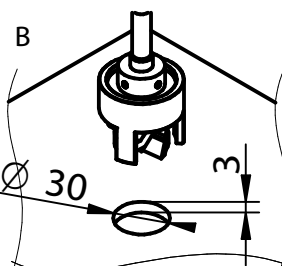

2. Copy with center punch

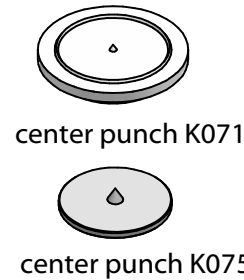
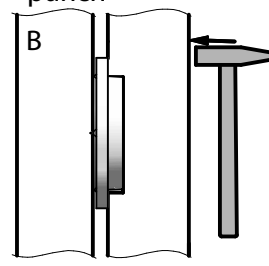

3. Screwing and connect

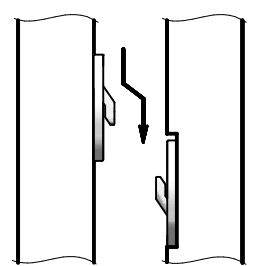

drill on both sides

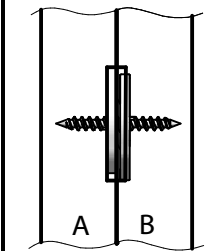

1. Drilling

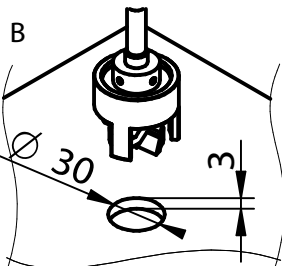

2. Copy

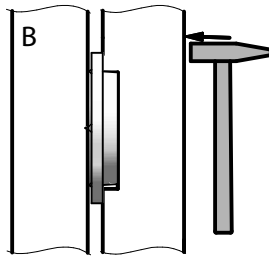

3. Drilling

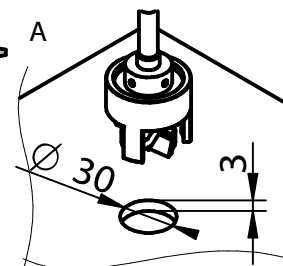

4. Screwing and connect

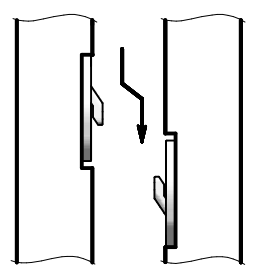

groove on one side

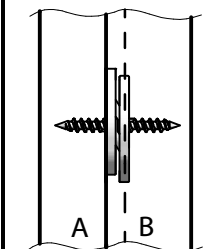

1. Grooving

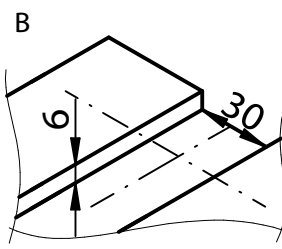

2. Copy

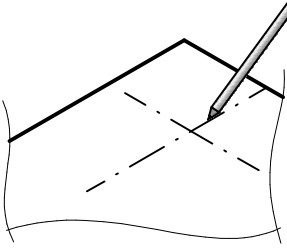

3. Screwing and connect

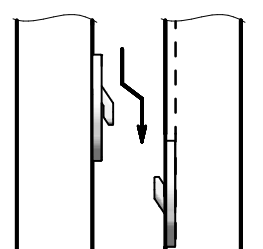

This drawing is the exclusive property of Knapp GmbH.

© Knapp GmbH. All measures in mm - Errors excepted. VERSION 02 08.09.2014

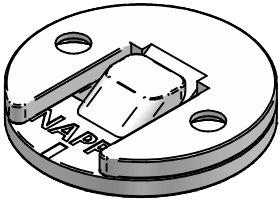

Construction Manual

DUO 30 ml/o

Hook connector

DUO 30 ml blue zinc-plated

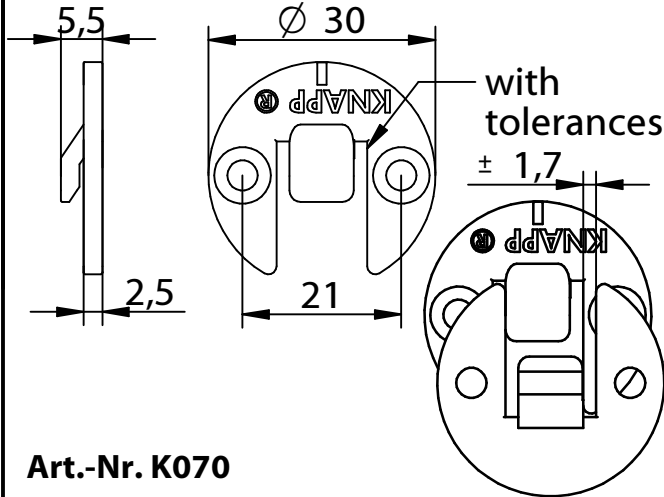

Art.-Nr. K070

DUO 30 ol yellow zinc-plated

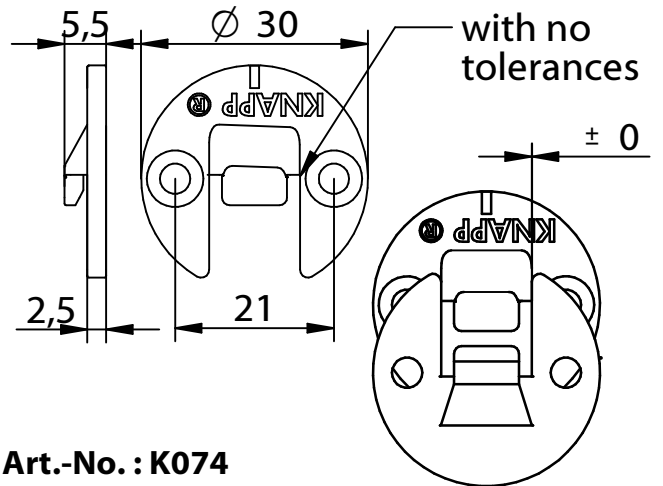

Art.-No. : K074

1. DUO 30 drilling (3 mm depth) according to mark

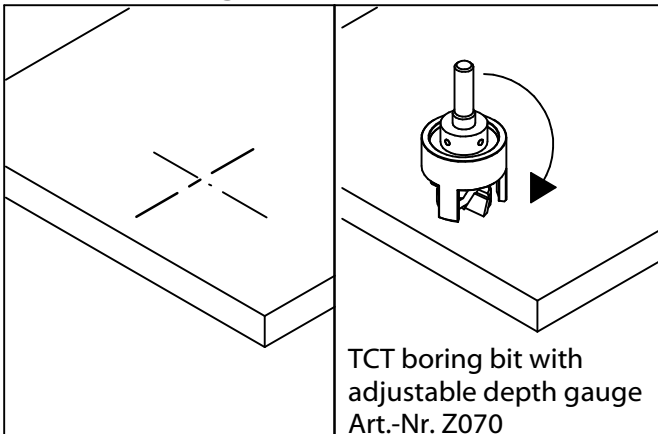

1. Adjust the drilling jig and drilling 3 mm depth

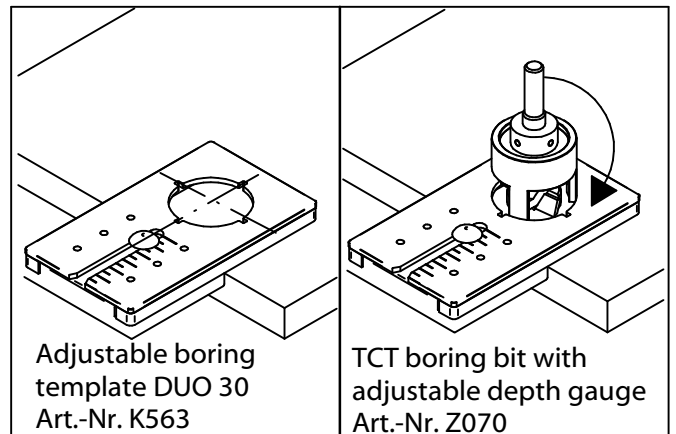

2. Copy with center punch

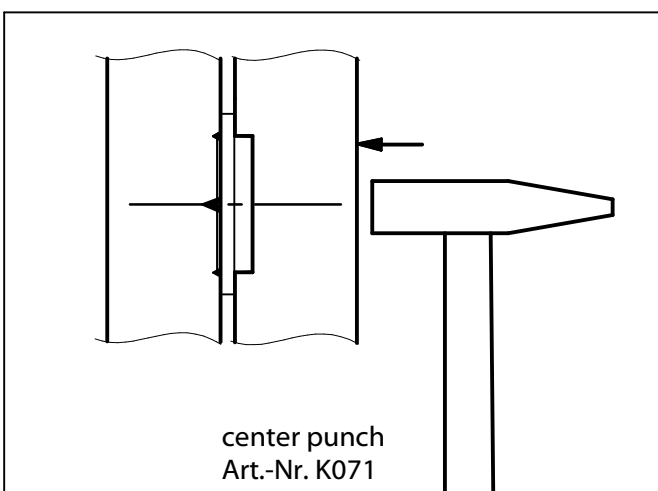

3. Screwing and connect

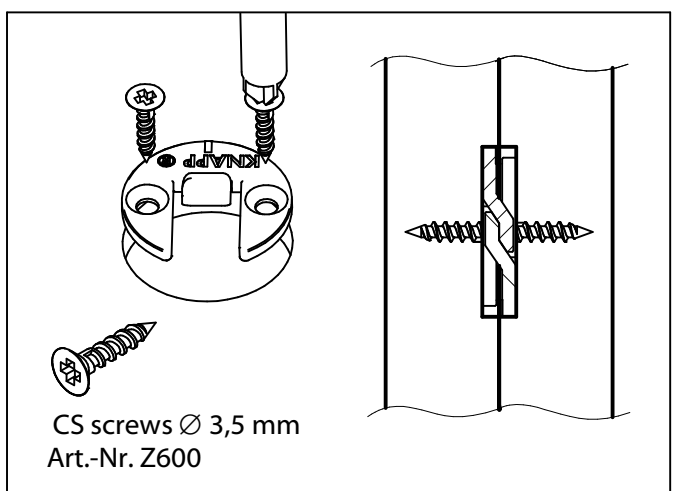

This drawing is the exclusive property of Knapp GmbH.

© Knapp GmbH. All measures in mm - Errors excepted. VERSION 02 08.09.2014

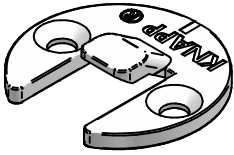

Notice de montage

DUO 30 ml

Réf. K070

Connecteur d'accroche

DUO 30 ml zingué bleu

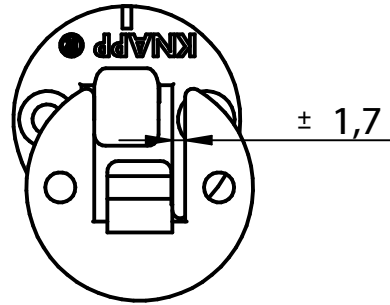
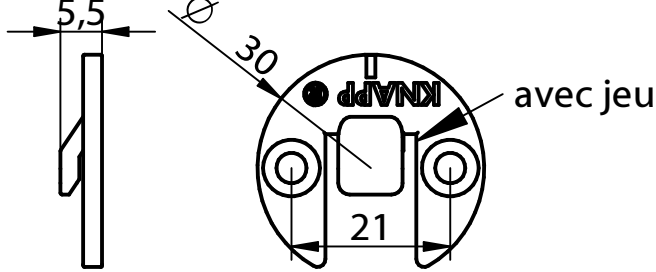

VARIANTE A

1. Visser

2. Accrocher

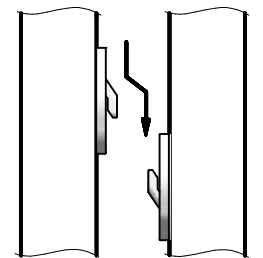
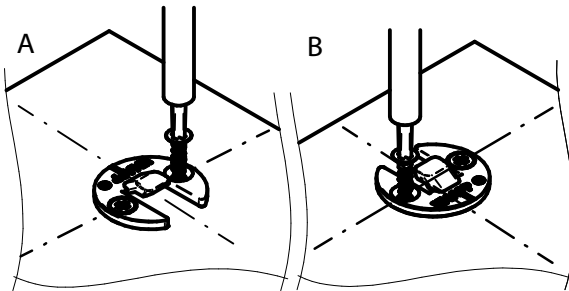
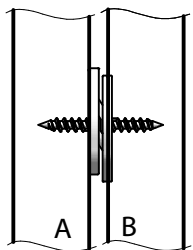

VARIANTE B

1. Percer

2. Pointer

3. Visser et accrocher

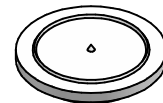
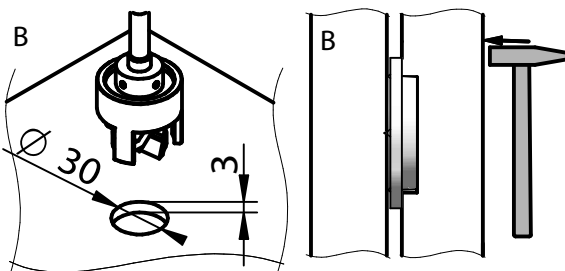
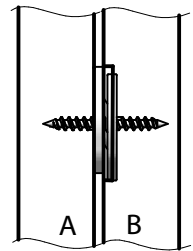

Pointeur K071



Pointeur K075

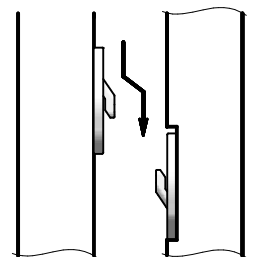

VARIANTE C

1. Percer

2. Pointer

3. Percer

4. Visser et accrocher

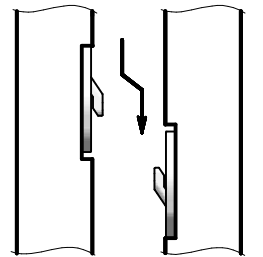
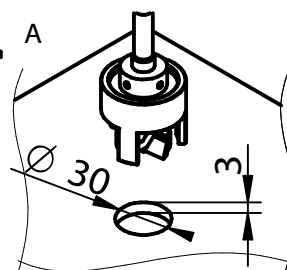
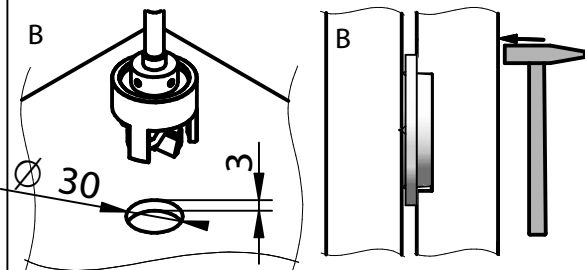
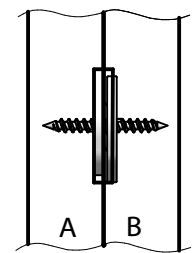

VARIANTE D

1. Rainurer

2. Pointer

3. Visser et accrocher

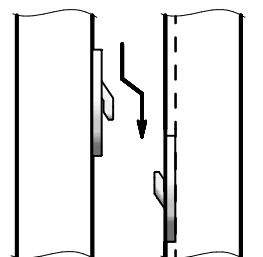
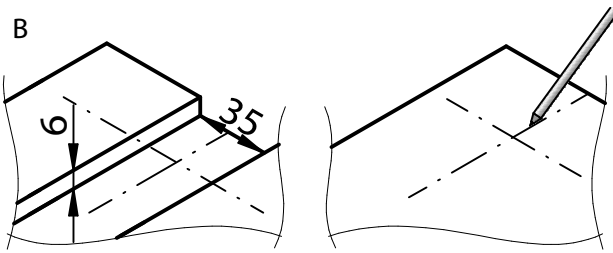
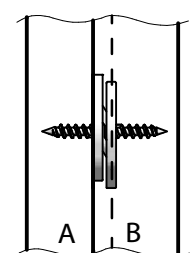

Ce dessin est la propriété de Knapp GmbH.

© Knapp GmbH. Toutes dimensions en mm - sauf erreurs, fautes d'impression ou modifications techniques. VERSION 02 08. 09. 2014



Notice de montage

DUO 30 ol

Réf. K074

Connecteur d'accroche

DUO 30 ol zingué jaune

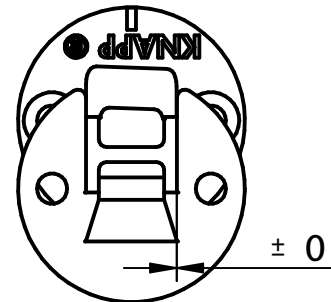
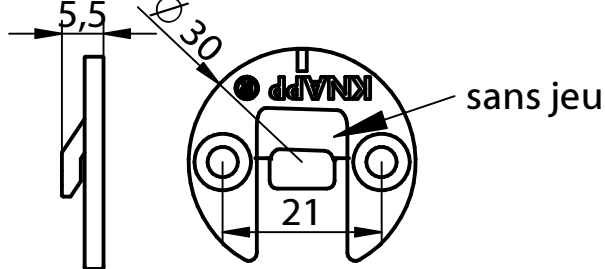

VARIANTE A

1. Visser

2. Accrocher

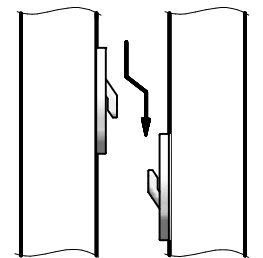
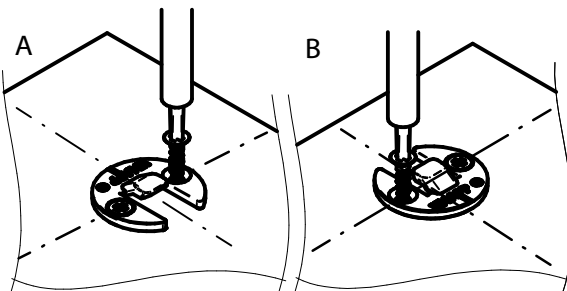
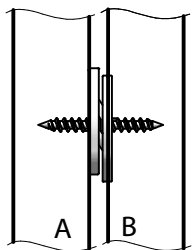

VARIANTE B

1. Percer

2. Pointer

3. Visser et accrocher

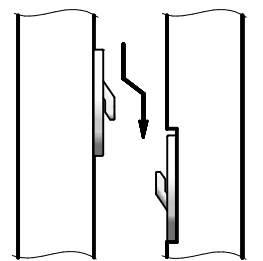
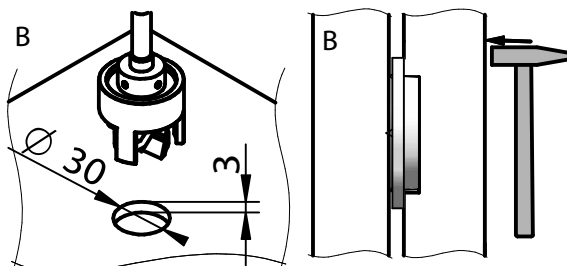
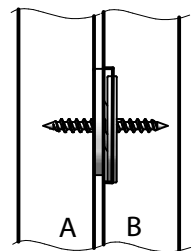

VARIANTE C

1. Percer

2. Pointer

3. Percer

4. Visser et accrocher

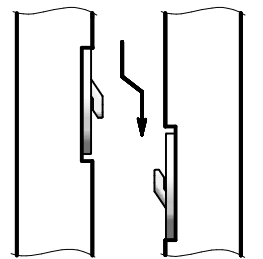
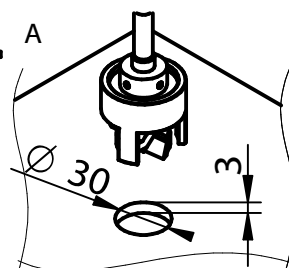
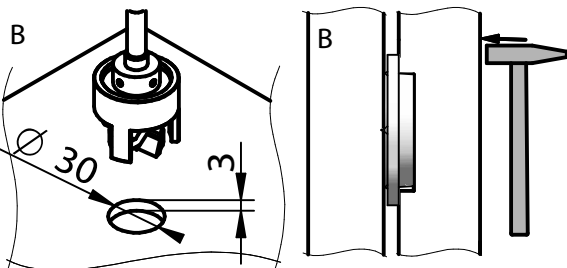
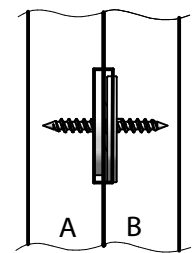

VARIANTE D

1. Rainurer

2. Pointer

3. Visser et accrocher

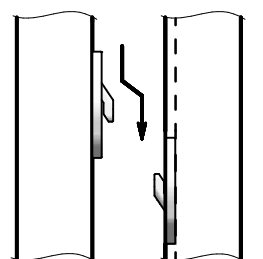
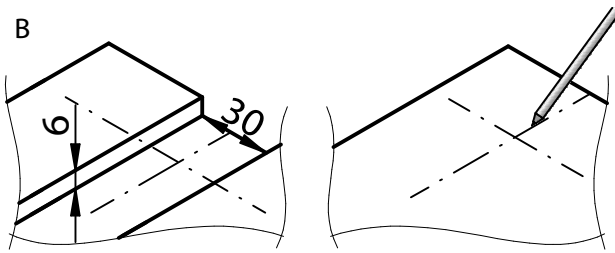
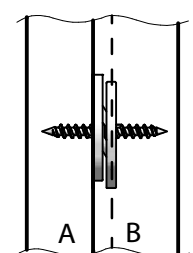

Ce dessin est la propriété de Knapp GmbH.

© Knapp GmbH. Toutes dimensions en mm - sauf erreurs, fautes d'impression ou modifications techniques. VERSION 02 08. 09. 2014

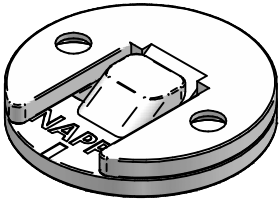

Notice de montage

DUO 30 ml/ol

Connecteur d'accroche

DUO 30 ml zingué bleu

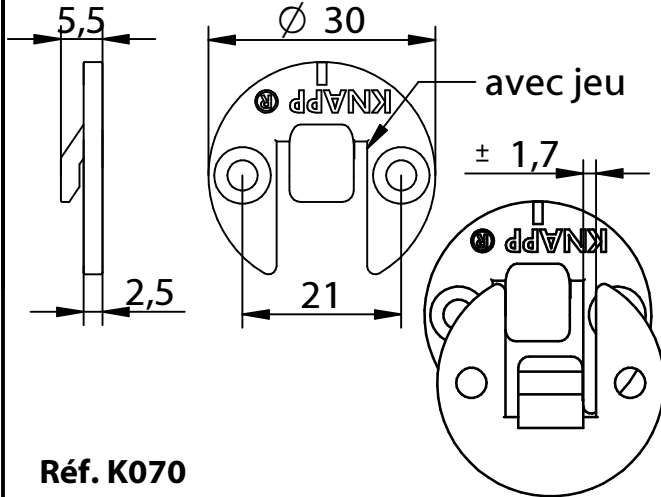

Réf. K070

DUO 30 ol zingué jaune

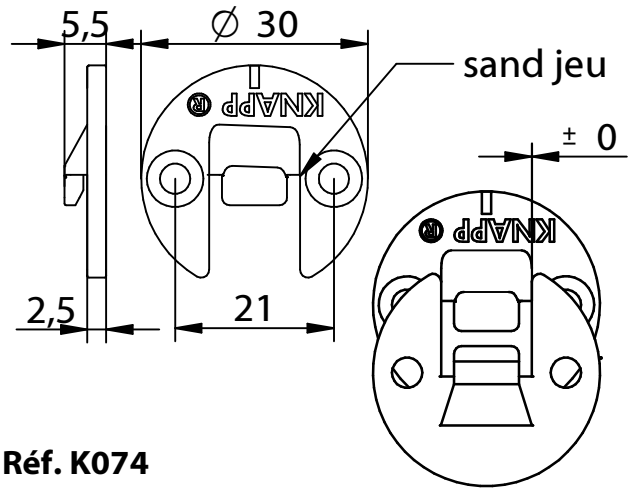

Réf. K074

1. Définir la position de DUO 30 et percer à 3 mm de profondeur

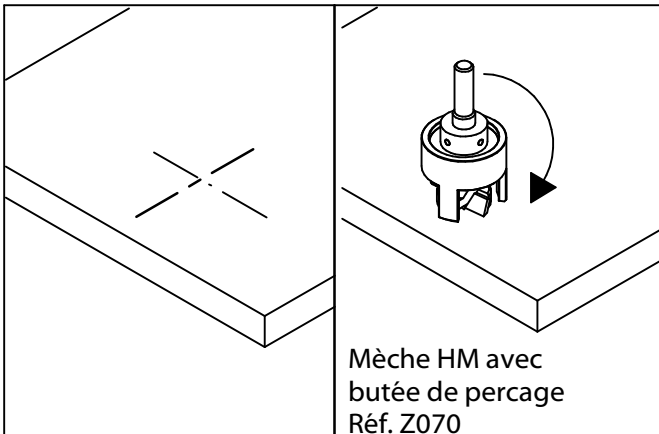

1. Régler le gabarit et percer à 3 mm de profondeur

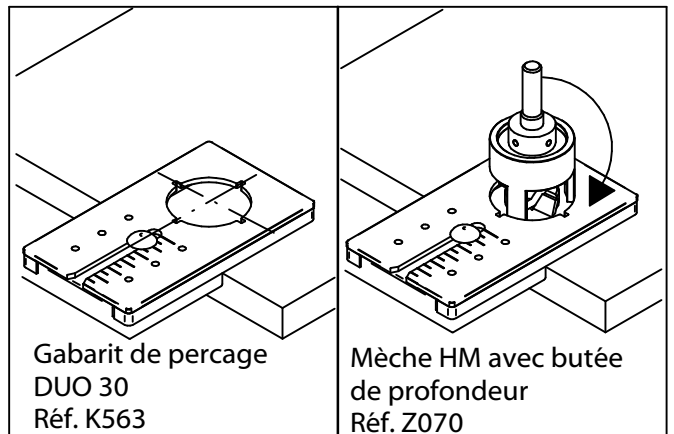

2. Pointer la pièce opposée

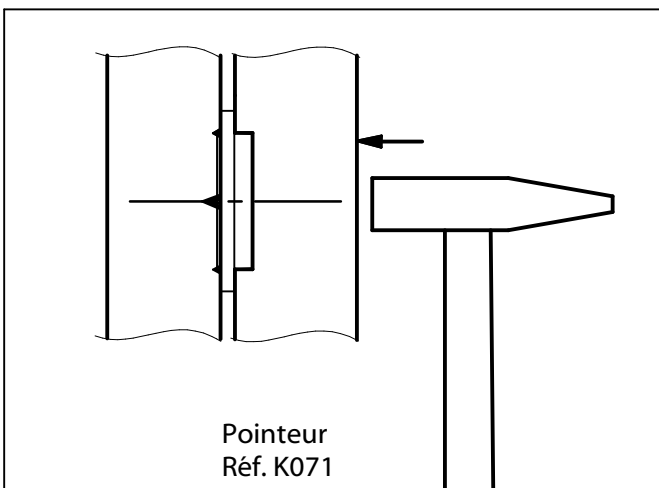

3. Visser et emboîter

