

Art.-Nr. K054

Montageanleitung

CLIPS

Steckverbinder

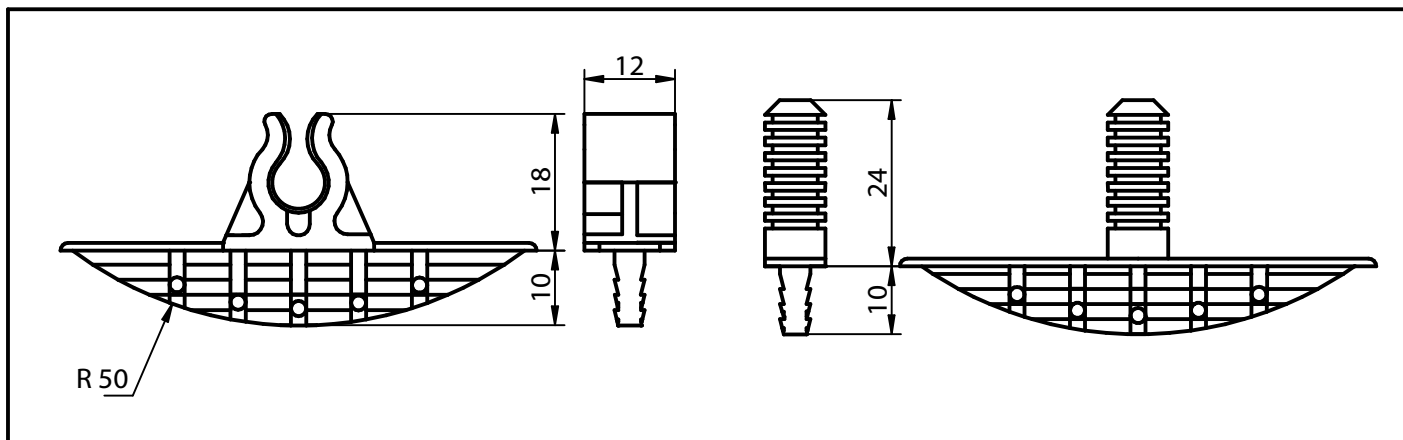

1. Fräsen

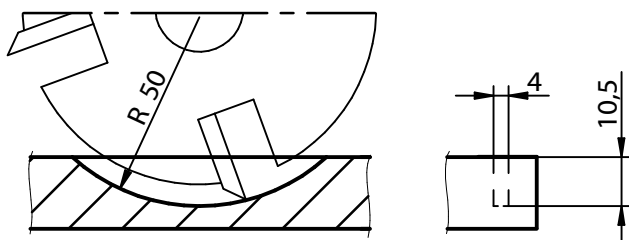

2. Kleben

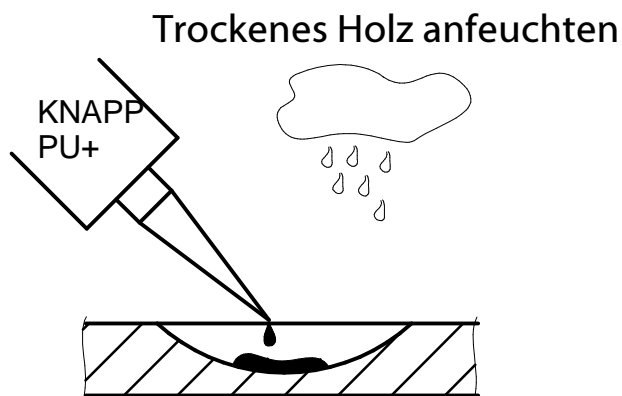

3. Einsetzen und Aushärten

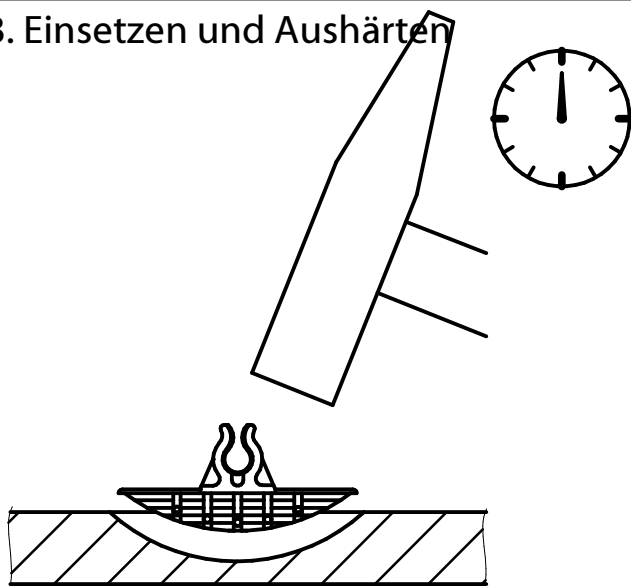

4. Montieren nach 60 Minuten Aushärtezeit

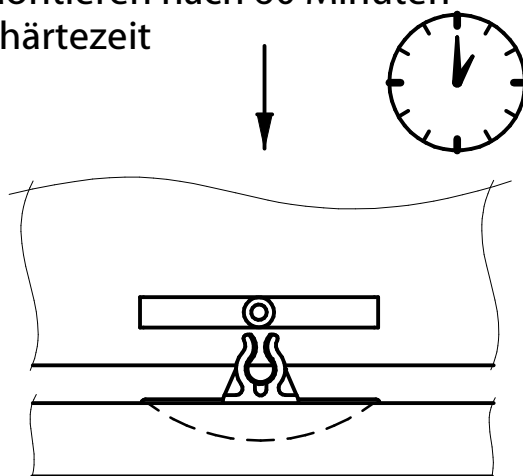

Diese Zeichnung ist Eigentum der Knapp GmbH.

© Knapp GmbH. - Alle Maße in mm - Irrtümer, Druckfehler und Änderungen vorbehalten. - VERSION 02 - 13. 08. 2014

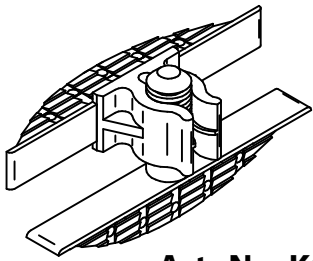

Art.-No. K054

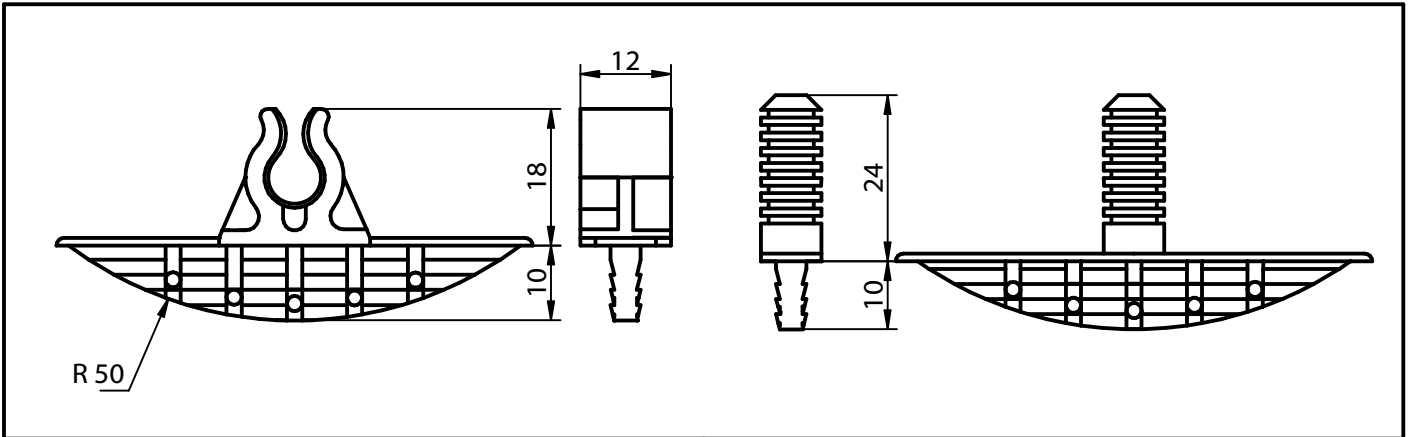

1. Routing

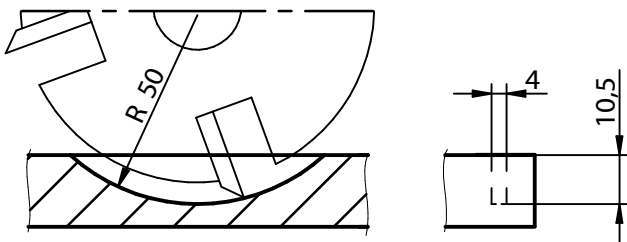

2. Gluing

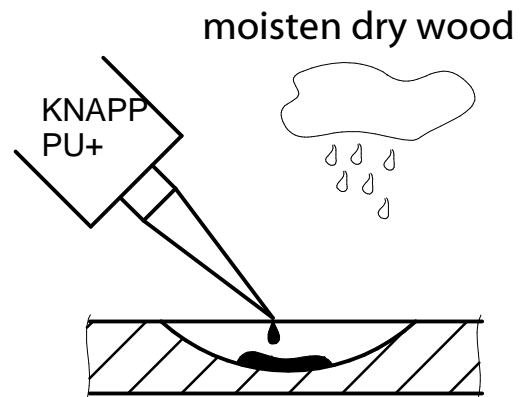

3. Insertion and curing

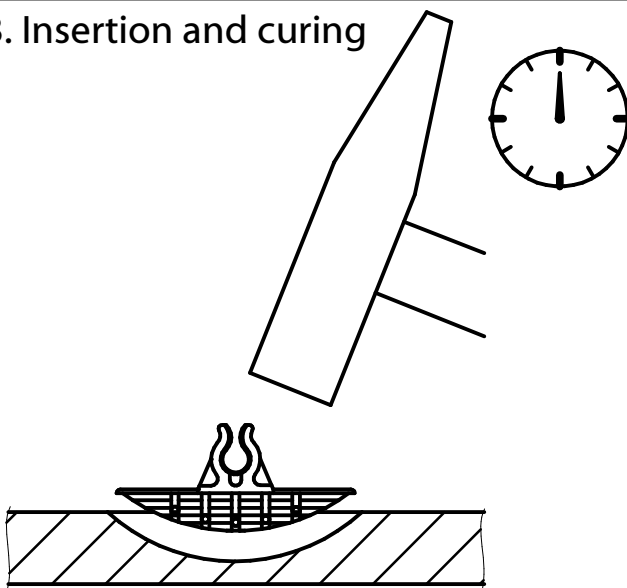

4. Assemble after 60 minutes curing time

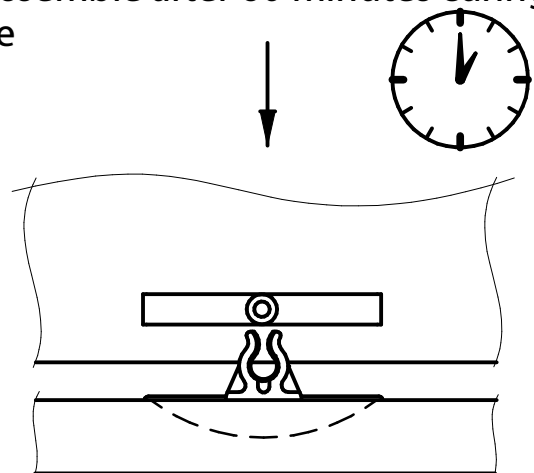

This drawing is the exclusive property of Knapp GmbH.

© Knapp GmbH. All measures in mm - Errors excepted. VERSION 02 13.08.2014

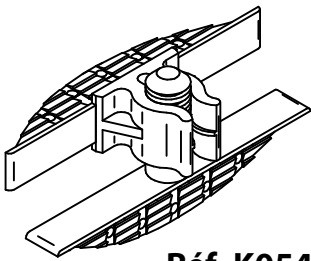

Réf. K054

Notice de montage

CLIPS

Assembleur à cliquer

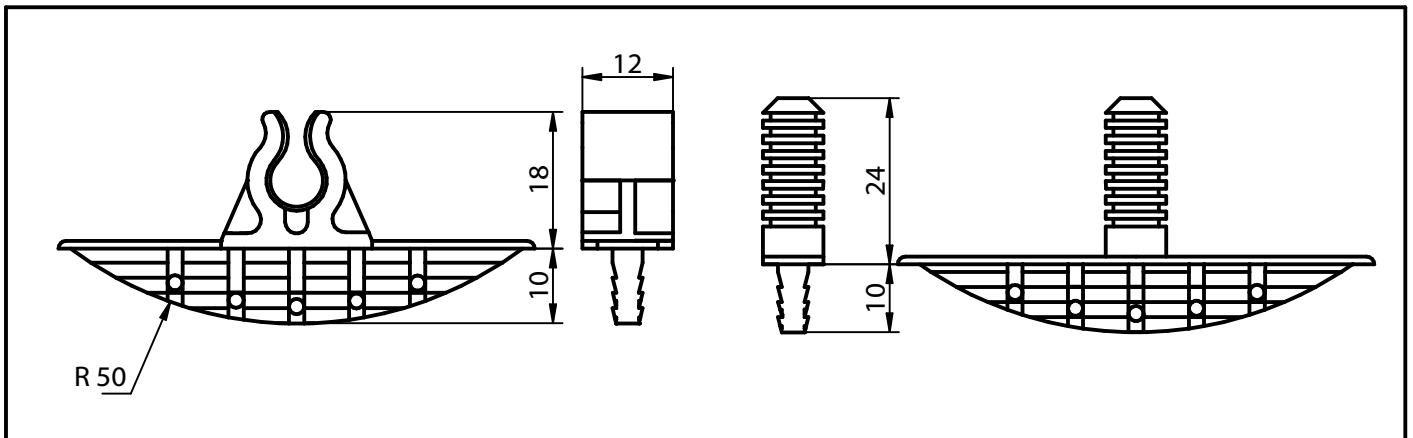

1. Fraiser

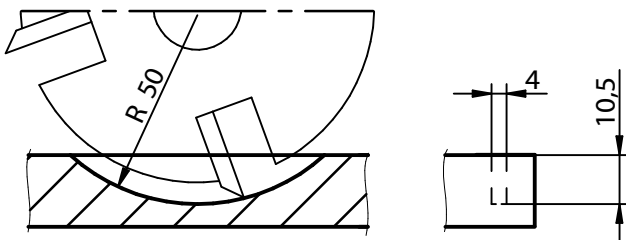

2. Coller

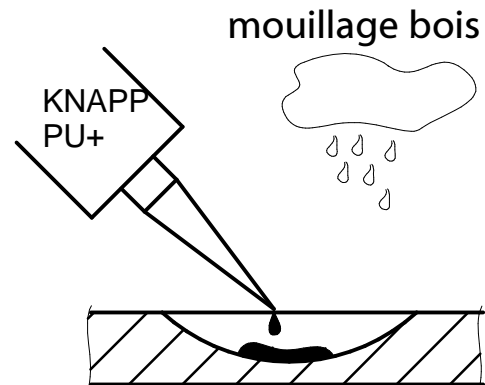

3. Insérer

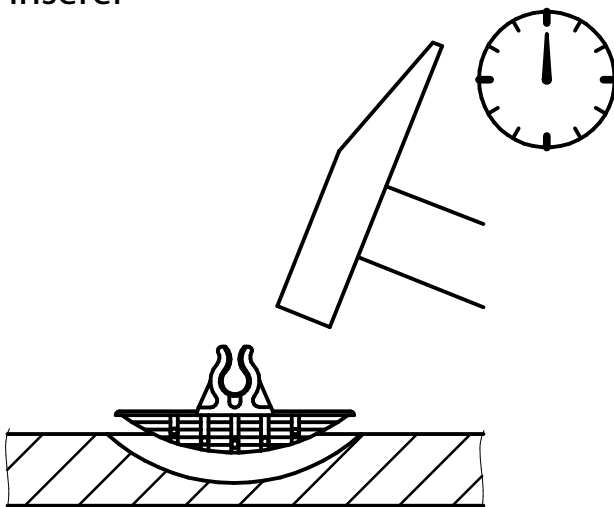

4. Attendre le durcissement (env. 60 min) et emboîter

