

Connecting systems

for modern post-beam wood-glass-facades

Certainly a great connection.

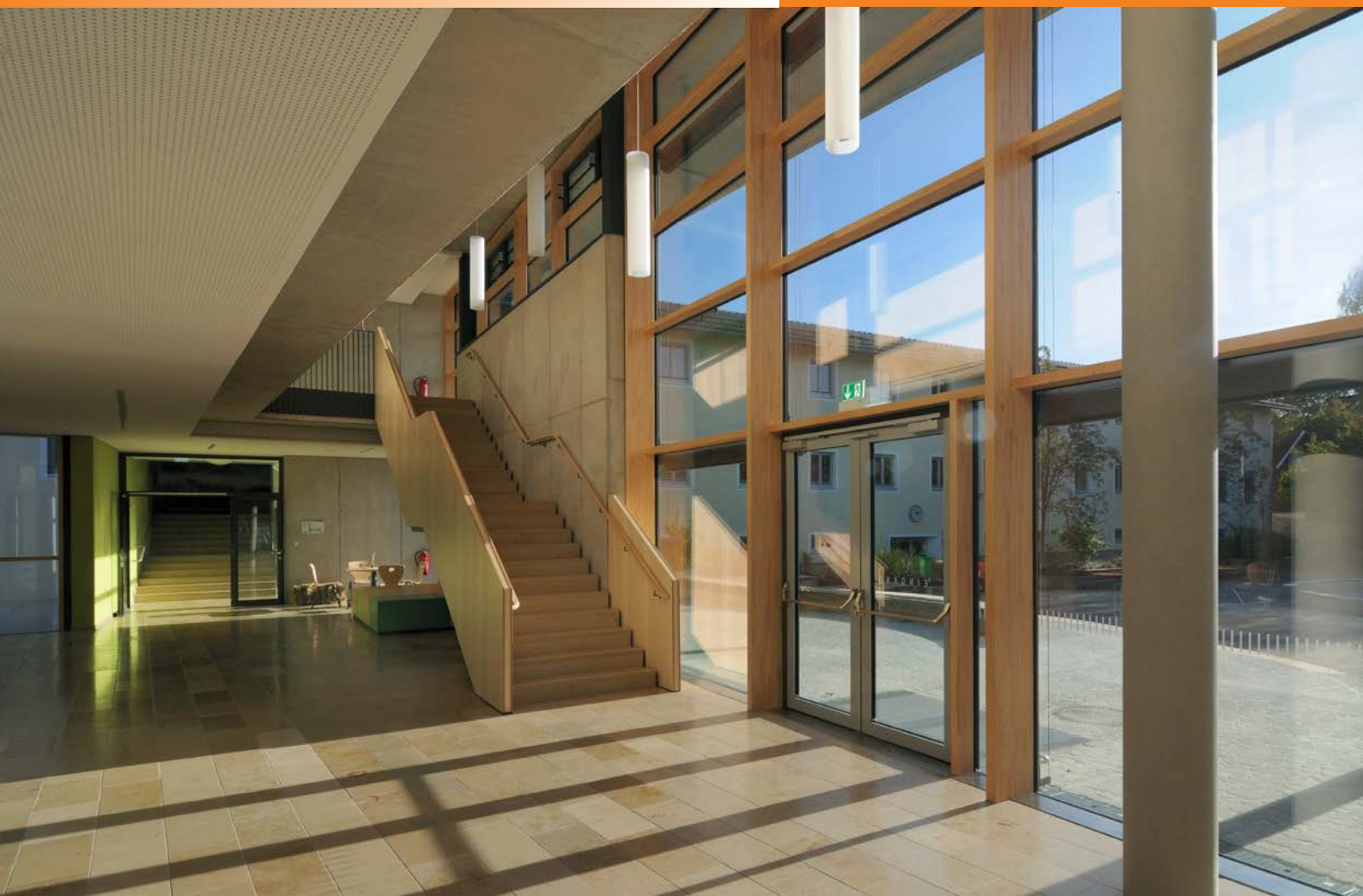

CE ETA

NEW | Additionally with hardwood material

KNAPP[®]
connectors.com

Welcome to the World of KNAPP®!

As a producer of patented connecting systems we develop and produce high-quality products which are distributed worldwide. Not only will our connecting systems convince – but also inspire you with the wide range of applications. The comprehensive service offers you the possibility to find the best, the most efficient and innovative solution for the realisation of your products. On the following pages you will find our connector systems for modern post-beam wood-glass-facades. Every connector permits high prefabrication and possesses the CE-Marking through European and German certification of standards. Regular external inspection guarantees maximum security for planners, architects, manufacturers and owners.



Friedrich Knapp

Our Service

The KNAPP®-Team provides competent advice and excellent service for your projects.

In Germany and Austria we offer full-coverage service by representatives on-site. You will find the right contact person easily and quickly.

www.knapp-connectors.com/ad

You can reach our internal consultants in Germany and Austria, Monday – Tuesday 8 a.m. to 5 p.m. and on Friday 8 a.m. to 13 p.m.

You can reach our global sales manager on phone +43 (0)664 / 88 51 52 87 or E-Mail : globalsales@knapp-connectors.com

www.knapp-connectors.com/contact

Our Planner Service



You can visit our online-shop 24 hours a day. Here you will receive comprehensive information about products and service. After one-time registration you will be able to use the download area.

www.knapp-connectors.com/download

We offer comprehensive planning and structural-engineering calculations for architects, planners and structural engineers. Contact us for your next project! We'd like to offer you statics pre-dimensioning, recommending the right connector from KNAPP®. Benefit from our know-how, many years of experience and rely on our engineers consulting.

www.knapp-connectors.com/planner



Planner service

KNAPP® online-store | Order around the clock

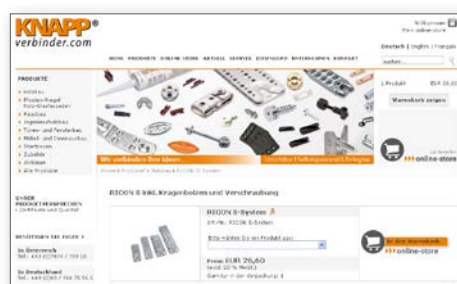

You want to be flexible and order at any time? No problem! In our online-store you can easily find the most fitting connecting system for any purpose and send your order by one mouse click. After a quick registration, you can immediately start buying online.

www.knapp-connectors.com/online-store



24h bestellen
online-store

KNAPP® offers the right connection for the areas of:

- Timber construction
- Post-beam wood-glass-facade
- Prefab walls
- Timber construction engineering
- Door- and window construction
- Furniture and interior design
- Glued glass elements for timber and metal construction



More information
www.knapp-connectors.com/folder



RICON® | The connector for main and secondary beam up to 26 kN*

System advantages:

- | Approved for eccentric loads up to 860 kg glass
- | Narrow profile – required timber width only 50 mm
- | Universal access to all wood materials, steel and concrete
- | Unique – for polygon facades
- | Flexible – installation from outside and inside
- | Always jointing – RICON® is adjustable to compensate timber tolerances
- | Versatile – can be used for single and dual port
- | Compatible with alu-profiles of RP, Schüco, MBJ, Guttmann, RAICO, Stabalux (more on request)
- | **NEW:** ETA additionally with hardwood material

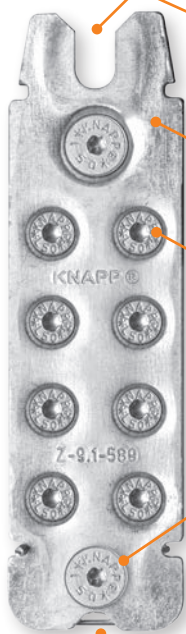

The dove-tail stamping makes it very easy to catch the CS-screws and push together the connector. It also ensures tightness.

RICON® consists of two identical parts. It is made of premium quality steel and is hot-dip galvanized and made in Austria.

Ø = 5 mm and Ø = 8 mm RICON® CS-screws. These adjustable holding screws compensate fabrication tolerances. The reinforced shaft with integrated stop guarantees exact positioning.

Clip in the stainless steel stirrup into the locating slots prior to final assembly. It locks the connection against the slide-in direction and can be released again.



Resistance to corrosion:
RICON® for indoor swimming pools. Special coating on request (for example near coastal areas).

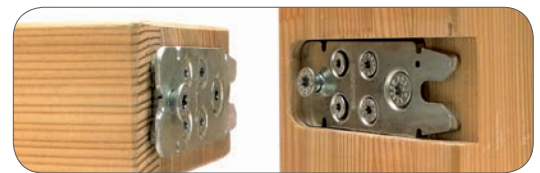

The RICON® can be milled in post and also in latch.

More information:
www.knapp-connectors.com/ricon

Charact. load carrying capacity $F_{2,Rk}$ in insertion direction applies only to the use of original KNAPP® cs-screws according to ETA 10/0189.

RICON®

Application examples and connection details

Post-beam wood-glass-facade

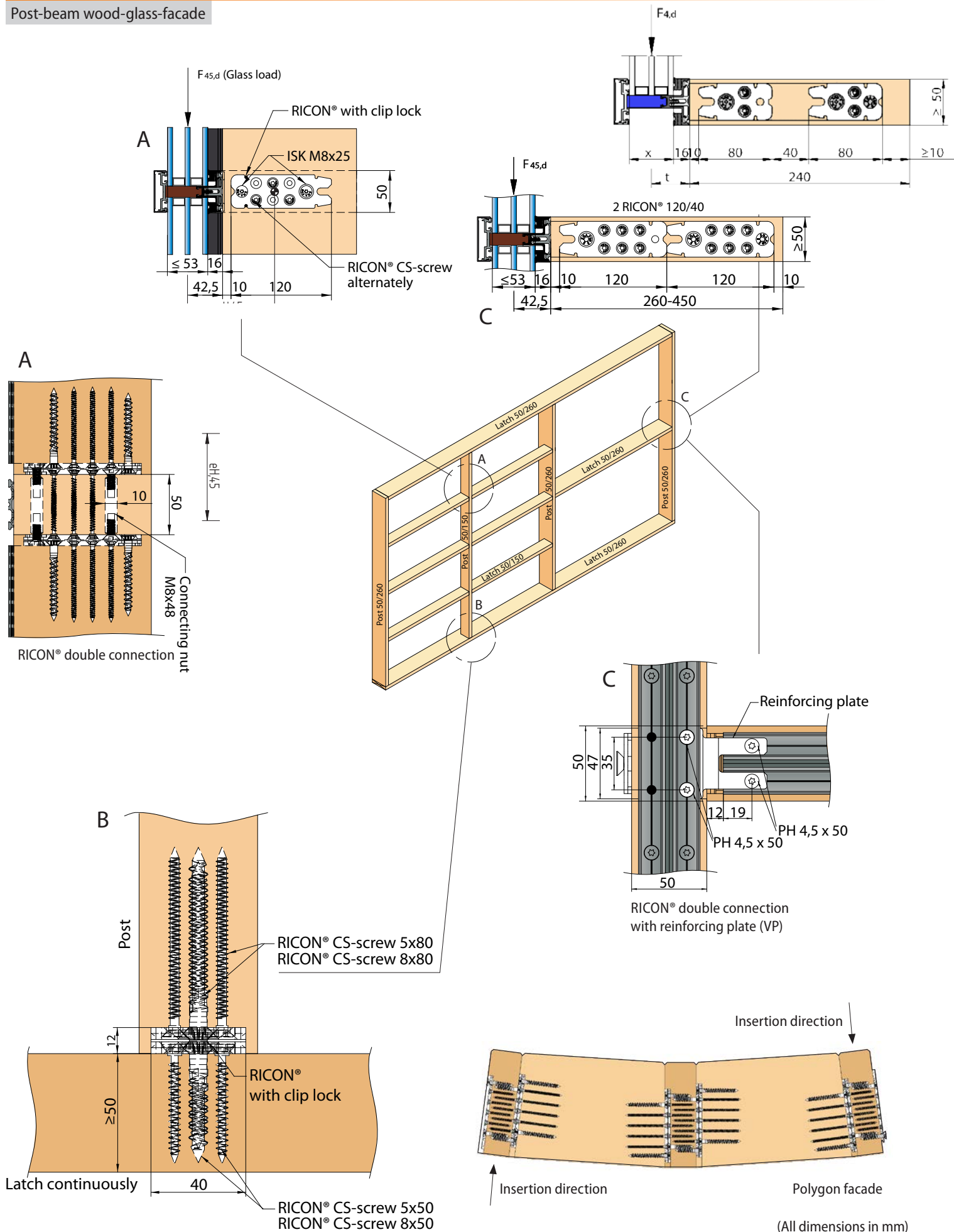

RICON® 60/40

Characteristic values for dimensioning can be taken from the ETA Static Folder.

Minimum timber cross section

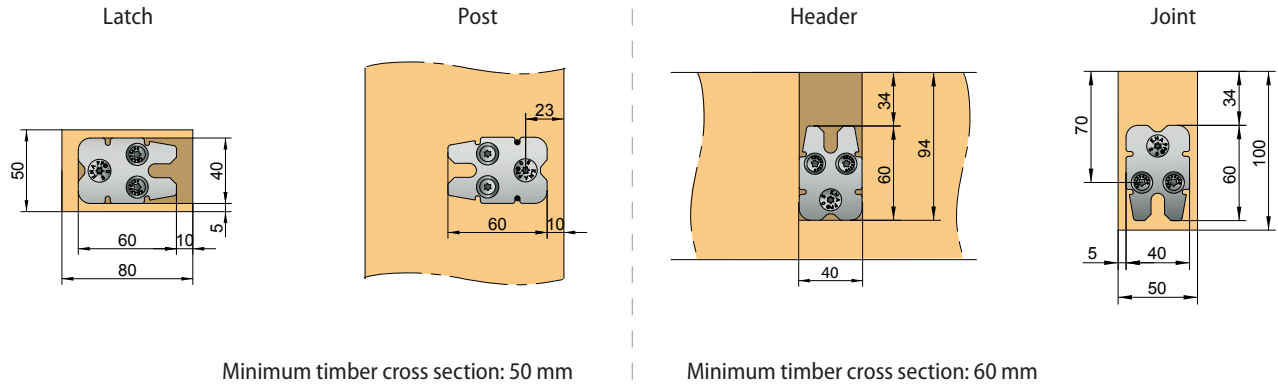

Single connection (EA) with RICON® CS-screws

Art.-No. K360

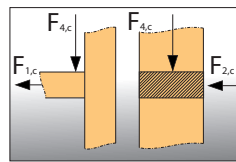
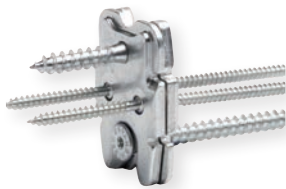

Single connection for post and latch connection with a minimum timber cross section of 50 mm (stress at mid to the axis of latch)

Connector	Connection	Screwing		Charact. values [GL24h]	
		Joint	Header	F _{1,Rk} [kN]	F _{2,Rk} [kN]
60/40	EA	2 x CS 5x80 1 x CS 8x80	2 x CS 5x50 1 x CS 8x50	6,3	5,8
1 stirrup: F _{3,Rk} = 2,7 kN			2 stirrups: F _{3,Rk} = 5,15 kN		

Minimum timber cross section : 50 x 80 mm

Double connection (DA) with connecting nuts and RICON® CS-screws

Art.-No. K160/48

The article number consists of the original number for the part K160 and the size of the connecting nut.

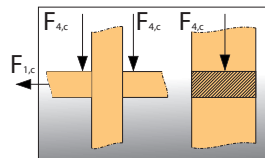
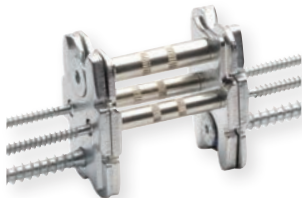

Double connection for 50/55/60/80 mm timber cross sections (stress at mid to the axis of latch)

Connector	Connection	Screwing		Charact. values [GL24h]	
		Joint	Header	F _{1,Rk} [kN]	F _{2,Rk} [kN]
60/40	DA	4 x CS 5x80 2 x CS 8x80	-	6,3	5,8
2 stirrups per set: F _{3,Rk} = 2,7 kN			4 stirrups per set: F _{3,Rk} = 5,15 kN		

Minimum timber cross section : 50 x 80 mm

Size (mm)	Connecting nuts				ISK-screw	
	48	53	58	78	M5x20	M8x25
8/M5	2	2	2	2	4	-
10/M8	1	1	1	1	-	2

Single or double connection with insert und RICON® CS-screws

Art.-No. K260

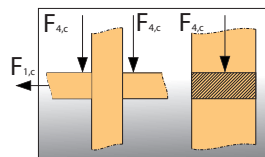
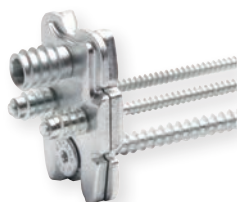

Single or double connection for special timber cross sections >50 mm (stress at mid to the axis of latch)

Connector	Connection	Screwing		Charact. values [GL24h]	
		Joint	Header	F _{1,Rk} [kN]	F _{2,Rk} [kN]
60/40	EAR	2 x CS 5x80 1 x CS 8x80	-	6,3	5,8
1 stirrup: F _{3,Rk} = 2,7 kN			2 stirrups: F _{3,Rk} = 5,15 kN		

Minimum timber cross section : 50 x 80 mm

Insert		ISK-screw	
M5x14	M8x18	M5x20	M8x25
2	1	2	1



RICON® 80/40

Characteristic values for dimensioning can be taken from the ETA Static Folder.

Minimum timber cross section

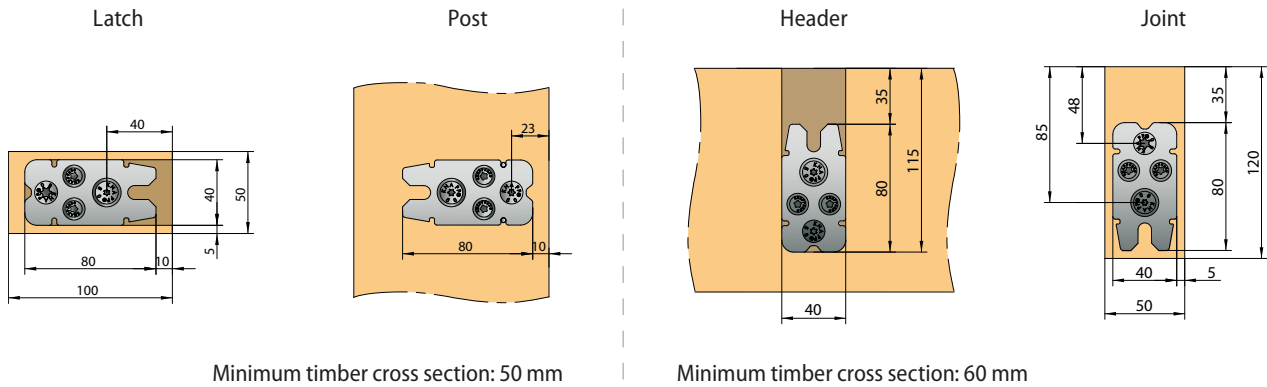

Minimum timber cross section: 50 mm

Minimum timber cross section: 60 mm

Single connection (EA) with RICON® CS-screws

Art.-No. K361

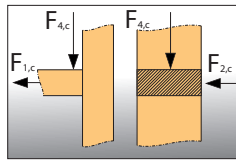
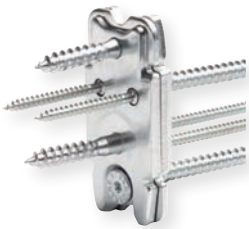

Single connection for post and latch connection with a minimum timber cross section of 50 mm (stress at mid to the axis of latch)

Connector	Connection	Screwing		Charact. values [GL24h]	
		Joint	Header	F _{1,Rk} [kN]	F _{2,Rk} [kN]
80/40	EA	2 x CS 5x80 2 x CS 8x80	2 x CS 5x50 2 x CS 8x50	10,3	9,5
1 stirrup: F _{3,Rk} = 2,7 kN			2 stirrups: F _{3,Rk} = 5,4 kN		

Minimum timber cross section : 50 x 100 mm

Double connection (DA) with connecting nuts and RICON® CS-screws

Art.-No. K161/48

*The article number consists of the original number for the part K161 and the size of the connecting nut.

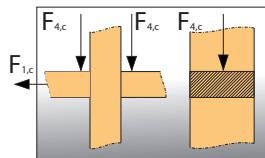
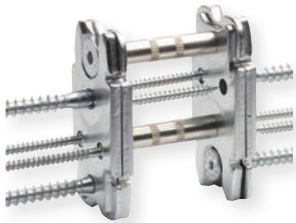

Double connection for 50/55/60/70/80 mm timber cross sections (stress at mid to the axis of latch)

Connector	Connection	Screwing		Charact. values [GL24h]	
		Joint	Header	F _{1,Rk} [kN]	F _{2,Rk} [kN]
80/40	DA	4 x CS 5x80 4 x CS 8x80	2 x CS 5x50	10,3	9,5
2 stirrups per set: F _{3,Rk} = 2,7 kN			4 stirrups per set: F _{3,Rk} = 5,4 kN		

Minimum timber cross section : 50 x 100 mm

Size (mm)	Connecting nuts						ISK-screw
	36	48	53	58	68	78	M8x25
10/M8	2	2	2	2	2	2	4

Single or double connection with insert und RICON® CS-screws

Art.-No. K261

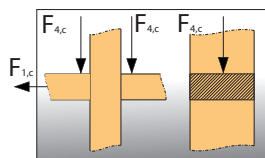

Single or double connection for special timber cross sections >50 mm (stress at mid to the axis of latch)

Connector	Connection	Screwing		Charact. values [GL24h]	
		Joint	Header	F _{1,Rk} [kN]	F _{2,Rk} [kN]
80/40	EAR	2 x CS 5x80 2 x CS 8x80	1 x CS 5x50	10,3	9,5
1 stirrup: F _{3,Rk} = 2,7 kN			2 stirrups: F _{3,Rk} = 5,4 kN		

Minimum timber cross section : 50 x 100 mm

Insert		ISK-screw	
M5x14	M8x18	M5x20	M8x25
-	2	-	2

RICON® 100/40

Characteristic values for dimensioning can be taken from the ETA Static Folder.

Minimum timber cross section

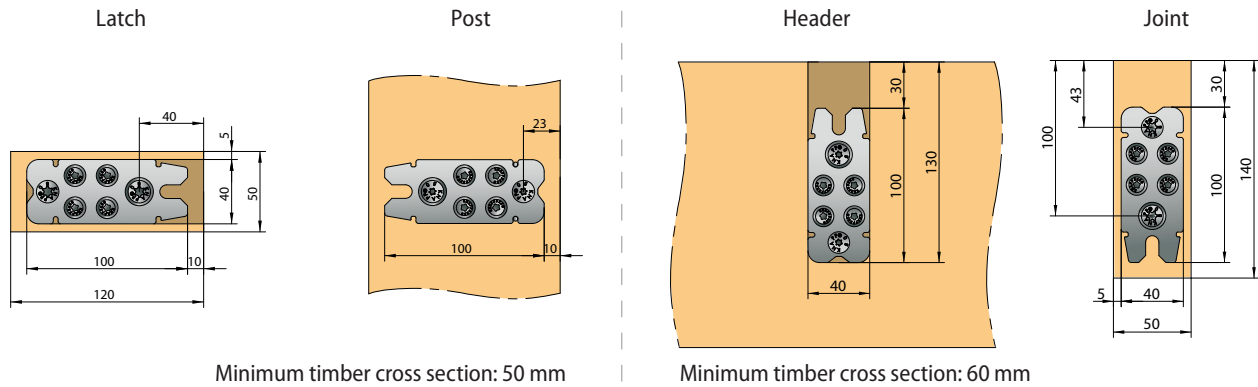

Single connection (EA) with RICON® CS-screws

Art.-No. K362

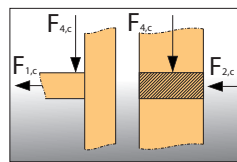

Single connection for post and latch connection with a minimum timber cross section of 50 mm (stress at mid to the axis of latch)

Connector	Connection	Screwing		Charact. values [GL24h]*	
		Joint	Header	F _{1,Rk} [kN]	F _{2,Rk} [kN]
100/40	EA	4 x CS 5x80 2 x CS 8x80	4 x CS 5x50 2 x CS 8x50	15,4	12,7
1 stirrup: F _{3,Rk} = 2,7 kN			2 stirrups: F _{3,Rk} = 5,4 kN		

Minimum timber cross section : 50 x 120 mm

Double connection (DA) with connecting nuts and RICON® CS-screws

Art.-No. K162/48

*The article number consists of the original number for the part K162 and the size of the connecting nut.

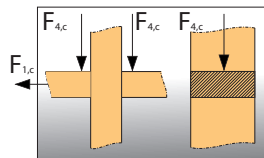
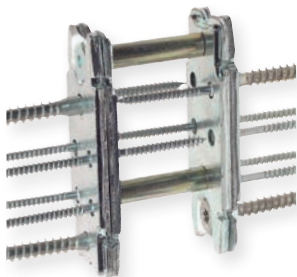

Double connection for 50/55/60/70/80 mm timber cross sections (stress at mid to the axis of latch)

Connector	Connection	Screwing		Charact. values [GL24h]*	
		Joint	Header	F _{1,Rk} [kN]	F _{2,Rk} [kN]
100/40	DA	8 x CS 5x80 4 x CS 8x80	4 x CS 8x80	15,4	12,7
2 stirrups per set: F _{3,Rk} = 2,7 kN			4 stirrups per set: F _{3,Rk} = 5,4 kN		

Minimum timber cross section : 50 x 120 mm

Size (mm)	Connecting nuts						ISK-screw
	36	48	53	58	68	78	M8x25
10/M8	2	2	2	2	2	2	4

Single or double connection with insert und RICON® CS-screws

Art.-No. K262

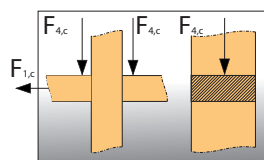

Single or double connection for special timber cross sections >50 mm (stress at mid to the axis of latch)

Connector	Connection	Screwing		Charact. values [GL24h]*	
		Joint	Header	F _{1,Rk} [kN]	F _{2,Rk} [kN]
100/40	EAR	4 x CS 5x80 2 x CS 8x80	2 x CS 5x50	15,4	12,7
1 stirrup: F _{3,Rk} = 2,7 kN			2 stirrups: F _{3,Rk} = 5,4 kN		

Minimum timber cross section : 50 x 120 mm

Insert		ISK-screw	
M5x14	M8x18	M5x20	M8x25
-	2	-	2

RICON® 120/40

Characteristic values for dimensioning can be taken from the ETA Static Folder.

Minimum timber cross section

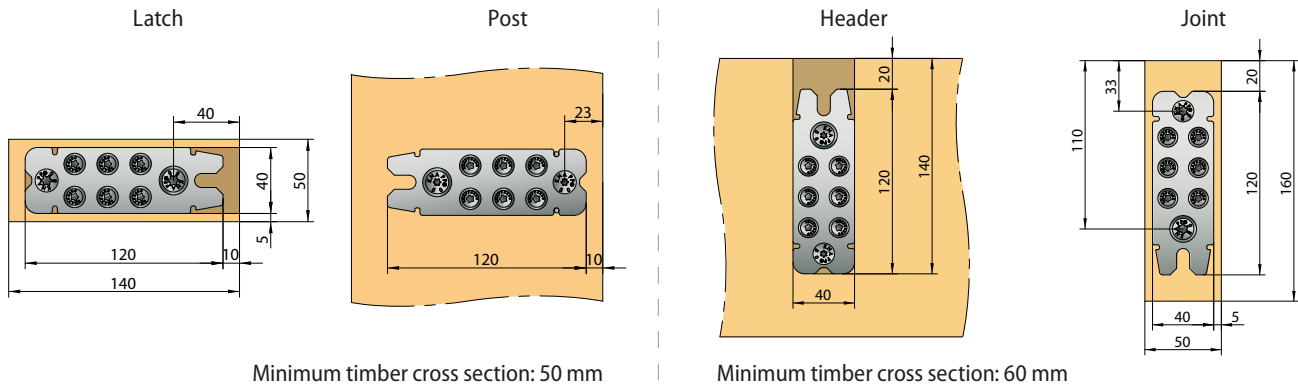

Single connection (EA) with RICON® CS-screws

Art.-No. K363

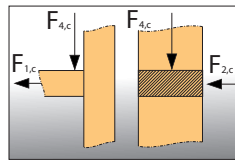

Single connection for post and latch connection with a minimum timber cross section of 50 mm (stress at mid to the axis of latch)

Connector	Connection	Screwing		Charact. values [GL24h]*	
		Joint	Header	F _{1,Rk} [kN]	F _{2,Rk} [kN]
120/40	EA	6 x CS 5x80 2 x CS 8x80	6 x CS 5x50 2 x CS 8x50	19,7	16,0
1 stirrup: F _{3,Rk} = 2,7 kN			2 stirrups: F _{3,Rk} = 5,4 kN		

Minimum timber cross section : 50 x 140 mm

Double connection (DA) with connecting nuts and RICON® CS-screws

Art.-No. K163/48

*The article number consists of the original number for the part K163 and the size of the connecting nut.

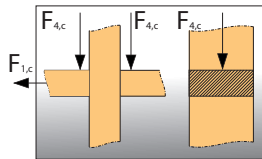

Double connection for 50/55/60/70/80 mm timber cross sections (stress at mid to the axis of latch)

Connector	Connection	Screwing		Charact. values [GL24h]*	
		Joint	Header	F _{1,Rk} [kN]	F _{2,Rk} [kN]
120/40	DA	12 x CS 5x80 4 x CS 8x80	6 x CS 5x50	19,7	16,0
2 stirrups per set: F _{3,Rk} = 2,7 kN			4 stirrups per set: F _{3,Rk} = 5,4 kN		

Minimum timber cross section : 50 x 140 mm

Size (mm)	Connecting nuts						ISK-screw
	36	48	53	58	68	78	M8x25
10/M8	2	2	2	2	2	2	4

Single or double connection with insert und RICON® CS-screws

Art.-No. K263

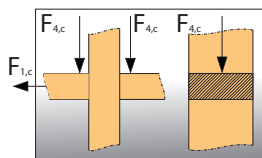

Single or double connection for special timber cross sections >50 mm (stress at mid to the axis of latch)

Connector	Connection	Screwing		Charact. values [GL24h]*	
		Joint	Header	F _{1,Rk} [kN]	F _{2,Rk} [kN]
120/40	EAR	6 x CS 5x80 2 x CS 8x80	3 x CS 5x50	19,7	16,0
1 stirrup: F _{3,Rk} = 2,7 kN			2 stirrups: F _{3,Rk} = 5,4 kN		

Minimum timber cross section : 50 x 140 mm

Insert		ISK-screw	
M5x14	M8x18	M5x20	M8x25
-	2	-	2

RICON® 140/40

Characteristic values for dimensioning can be taken from the ETA Static Folder.

Minimum timber cross section

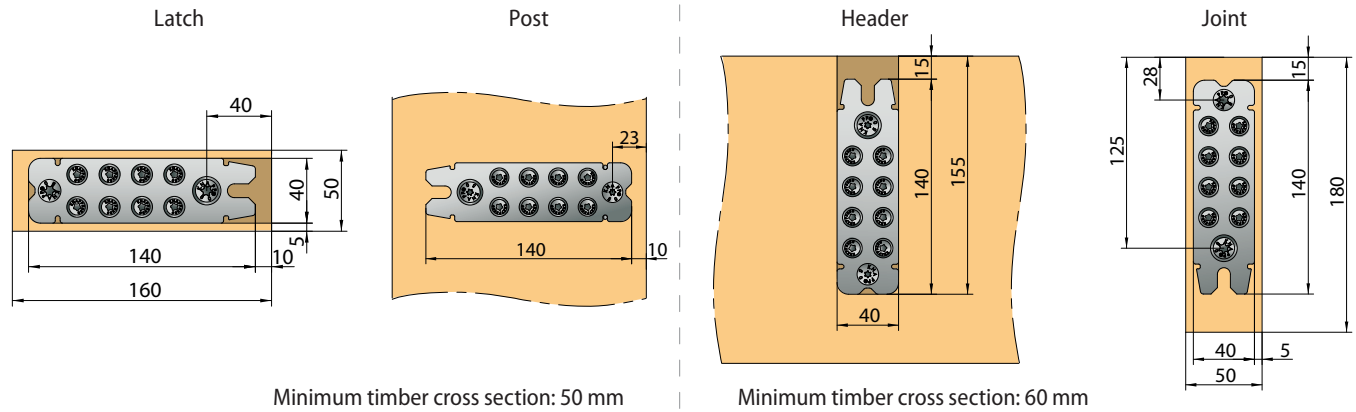

Single connection (EA) with RICON® CS-screws

Art.-No. K365

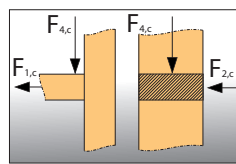

Single connection for post and latch connection with a minimum timber cross section of 50 mm (stress at mid to the axis of latch)

Connector	Connection	Screwing		Charact. values [GL24h]*	
		Joint	Header	F _{1,Rk} [kN]	F _{2,Rk} [kN]
140/40	EA	8 x CS 5x80 2 x CS 8x80	8 x CS 5x50 2 x CS 8x50	24,1	17,3
1 stirrup: F _{3,Rk} = 2,7 kN			2 stirrups: F _{3,Rk} = 5,4 kN		

Minimum timber cross section : 50 x 160 mm

Double connection (DA) with connecting nuts and RICON® CS-screws

Art.-No. K165/48

*The article number consists of the original number for the part K165 and the size of the connecting nut.

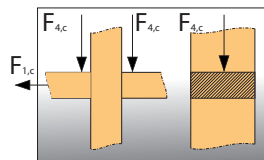

Double connection for 50/55/60/70/80 mm timber cross sections (stress at mid to the axis of latch)

Connector	Connection	Screwing		Charact. values [GL24h]*	
		Joint	Header	F _{1,Rk} [kN]	F _{2,Rk} [kN]
140/40	DA	16 x CS 5x80 4 x CS 8x80	8 x CS 5x50	24,1	17,3
2 stirrups per set: F _{3,Rk} = 2,7 kN			4 stirrups per set: F _{3,Rk} = 5,4 kN		

Minimum timber cross section : 50 x 160 mm

Size (mm)	Connecting nuts						ISK-screw
	36	48	53	58	68	78	M8x25
10/M8	2	2	2	2	2	2	4

Single or double connection with insert und RICON® CS-screws

Art.-No. K265

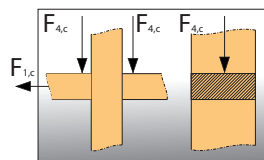

Single or double connection for special timber cross sections >50 mm (stress at mid to the axis of latch)

Connector	Connection	Screwing		Charact. values [GL24h]*	
		Joint	Header	F _{1,Rk} [kN]	F _{2,Rk} [kN]
140/40	EAR	8 x CS 5x80 2 x CS 8x80	4 x CS 5x50	24,1	17,3
1 stirrup: F _{3,Rk} = 2,7 kN			2 stirrups: F _{3,Rk} = 5,4 kN		

Minimum timber cross section : 50 x 160 mm

Insert		ISK-screw	
M5x14	M8x18	M5x20	M8x25
-	2	-	2

RICON® 160/40

Characteristic values for dimensioning can be taken from the ETA Static Folder.

Minimum timber cross section

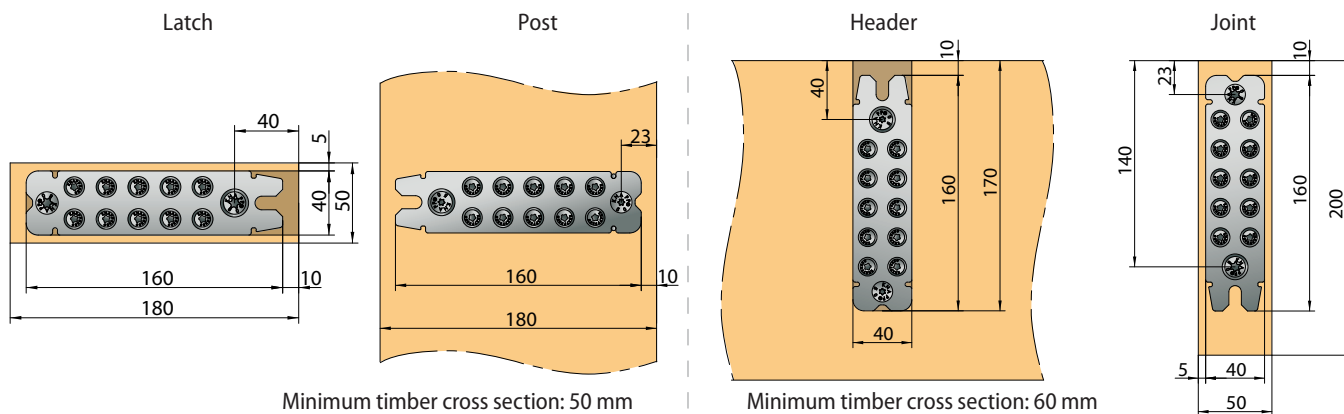

Minimum timber cross section: 50 mm

Minimum timber cross section: 60 mm

Single connection (EA) with RICON® CS-screws

Art.-No. K364

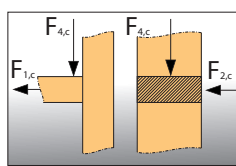

Single connection for post and latch connection with a minimum timber cross section of 50 mm (stress at mid to the axis of latch)

Connector	Connection	Screwing		Charact. values [GL24h]*	
		Joint	Header	F _{1,Rk} [kN]	F _{2,Rk} [kN]
160/40	EA	10 x CS 5x80 2 x CS 8x80	10 x CS 5x50 2 x CS 8x50	26,0	17,3
1 stirrup: F _{3,Rk} = 2,7 kN			2 stirrups: F _{3,Rk} = 5,4 kN		

Minimum timber cross section : 50 x 180 mm

Double connection (DA) with connecting nuts and RICON® CS-screws

Art.-No. K164/48

*The article number consists of the original number for the part K164 and the size of the connecting nut.

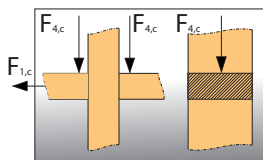
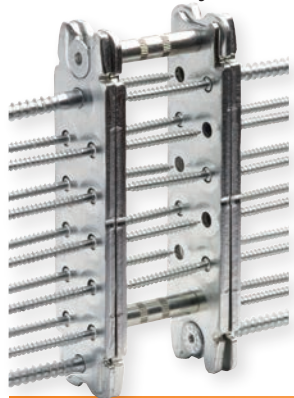

Double connection for 50/55/60/70/80 mm timber cross sections (stress at mid to the axis of latch)

Connector	Connection	Screwing		Charact. values [GL24h]*	
		Joint	Header	F _{1,Rk} [kN]	F _{2,Rk} [kN]
160/40	DA	20 x CS 5x80 4 x CS 8x80	10 x CS 5x50	26,0	17,3
2 stirrups per set: F _{3,Rk} = 2,7 kN			4 stirrups per set: F _{3,Rk} = 5,4 kN		

Minimum timber cross section : 50 x 180 mm

Size (mm)	Connecting nuts						ISK-screw
	36	48	53	58	68	78	M8x25
10/M8	2	2	2	2	2	2	4

Single or double connection with insert und RICON® CS-screws

Art.-No. K264

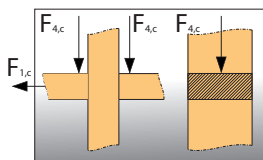

Single or double connection for special timber cross sections >50 mm (stress at mid to the axis of latch)

Connector	Connection	Screwing		Charact. values [GL24h]*	
		Joint	Header	F _{1,Rk} [kN]	F _{2,Rk} [kN]
160/40	EAR	10 x CS 5x80 2 x CS 8x80	5 x CS 5x50	26,0	17,3
1 stirrup: F _{3,Rk} = 2,7 kN			2 stirrups: F _{3,Rk} = 5,4 kN		

Minimum timber cross section : 50 x 180 mm

Insert		ISK-screw	
M5x14	M8x18	M5x20	M8x25
-	2	-	2

RICON®

Load capacity

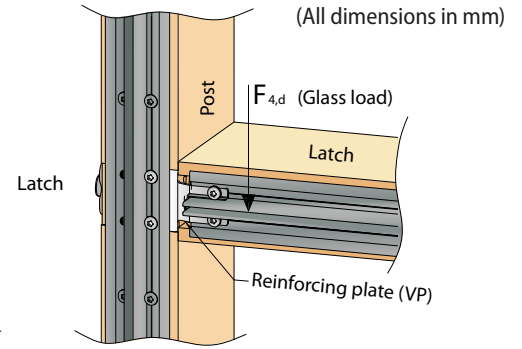
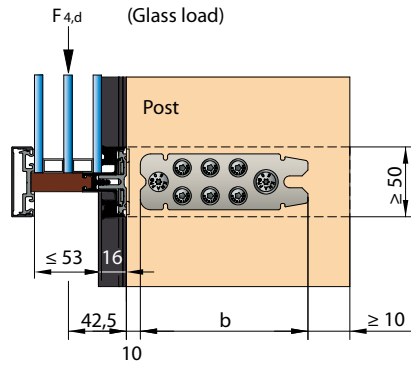
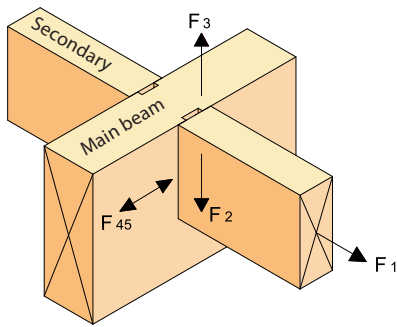

RICON®	Wood material	Charact. values			Design value $R_{la,i,c}$ [kN] = $F_{3,Rk}$		Eccentric glass loads/post $R_{la,r,d}$	
		$R_{ax,k} = F_{1,Rk}$ [kN]	$R_{la,i,k} = F_{2,Rk}$ [kN]	$R_{la,r,k} = F_{45,Rk}$ [kN]	Stirrups		with VP [kg]	without VP [kg]
					1	2		
60/40	C24h (S10)	7,8	6,0	5,8	2,7	5,5	66	339
	GL24h (BS11)	8,4	6,3	5,8			70	344
	GL32h (BS16)	9,2	6,9	5,8			78	352
80/40	C24h (S10)	7,8	9,7	8,9	2,7	5,5	86	359
	GL24h (BS11)	8,4	10,3	9,5			92	365
	GL32h (BS16)	9,2	11,3	10,5			102	375
100/40	C24h (S10)	7,8	14,5	11,8	2,7	5,5	134	407
	GL24h (BS11)	8,4	15,4	12,7			143	417
	GL32h (BS16)	9,2	16,9	14,0			159	432
120/40	C24h (S10)	7,8	18,6	15,0	2,7	5,5	183	456
	GL24h (BS11)	8,4	19,7	16,0			196	469
	GL32h (BS16)	9,2	21,6	17,3			217	490
140/40	C24h (S10)	7,8	22,7	17,3	2,7	5,5	233	507
	GL24h (BS11)	8,4	24,1	17,3			249	523
	GL32h (BS16)	9,2	26,0	17,3			277	550
160/40	C24h (S10)	7,8	26,0	17,3	2,7	5,5	286	559
	GL24h (BS11)	8,4	26,0	17,3			306	580
	GL32h (BS16)	9,2	26,0	17,3			339	613
2 x 80/40	C24h (S10)	7,8	15,9	11,6	2,7	5,5	246	520
	GL24h (BS11)	8,4	15,9	11,6			264	537
	GL32h (BS16)	9,2	15,9	11,6			293	566
2 x 100/40	C24h (S10)	7,8	20,2	14,4	2,7	5,5	363	637
	GL24h (BS11)	8,4	20,2	14,4			389	663
	GL32h (BS16)	9,2	20,2	14,4			431	705
2 x 120/40	C24h (S10)	7,8	26,0	17,3	2,7	5,5	473	746
	GL24h (BS11)	8,4	26,0	17,3			506	780
	GL32h (BS16)	9,2	26,0	17,3			561	835

Detailed information for the structural analysis are given in the ETA STATICS FOLDER.
Further information at: www.knapp-connectors.com/download

Tested: at the University of Karlsruhe (KIT), **Building approval:** ETA-10/0189,

Monitored: at the University of Karlsruhe (KIT) Research Center for Steel, Timber and Masonry, Univ.-Prof. Dr.-Ing. Blaß

- $F_{1,Rk}/F_{1,Rd}$
- $F_{2,Rk}/F_{2,Rd}$
- $F_{3,Rk}/F_{3,Rd}$
- $F_{45,Rk}/F_{45,Rd}$
- $F_{KCC,Rk}/F_{KCC,Rd}$
- $e_{H,45}$
- γ_M
- k_{mod}

Characteristic/Design values of load-bearing capacity in the case of single stress perpendicular to the connector plate
 Characteristic/Design values in direction of insertion
 Characteristic/Design values against the direction of insertion
 Characteristic/Design values perpendicular to the direction of insertion
 Characteristic/Design values capacity of KNAPP Clip Connector (steel failure)
 Distance between the force F_{45} and the centroid of the fasteners in the joist or in the header
 Partial factor for material properties, also accounting for model uncertainties and dimensional variations
 Modification factors for duration of load and moisture content
 $k_{mod} = 0,6 \Rightarrow$ Permanent (more than 10 years for example self weight)
 $k_{mod} = 0,7 \Rightarrow$ Long term (6 months - 10 years for example storage)
 $k_{mod} = 0,8 \Rightarrow$ Medium term (1 week - 6 months for example imposed floor load, snow load)
 $k_{mod} = 0,9 \Rightarrow$ Short term (shorter one week for example snow- and wind load)

RICON® screws

RICON® CS-screws with reinforced shaft and cut-point (CS-screws are included with delivery)

Art.-No. Z533 CS-screws 5x50

Art.-No. Z531 CS-screws 8x50

Application: For longitudinal screwing of RICON® connectors (post).

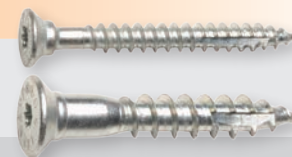

Art.-No. Z534 CS-screws 5x80

Art.-No. Z532 CS-screws 8x80

Application: For end grain screwing of RICON® connectors (latch).

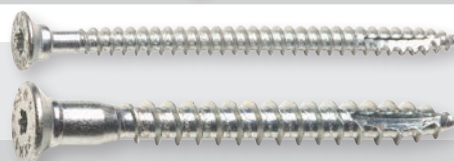

CS-screws RICON® DA

Art.-No. Z545 CS-screw M5x20 (for RICON® 60/40 DA)

Art.-No. Z548 CS-screw M8x25

Application: For screwing RICON® double connections (DA).



Connecting nuts RICON® DA

(Connecting nuts are included with delivery)

Art.-No. K540 Connecting nut M5 8x48 50 mm post thickness

Art.-No. K541 Connecting nut M5 8x53 55 mm post thickness

Art.-No. K542 Connecting nut M5 8x58 60 mm post thickness

Art.-No. K543 Connecting nut M5 8x78 80 mm post thickness

Utilisation: For screwing RICON® 60/40 double connections (DA).



Art.-No. K544 Connecting nut M8 10x36 <50 mm post thickness

Art.-No. K545 Connecting nut M8 10x48 50 mm post thickness

Art.-No. K546 Connecting nut M8 10x53 55 mm post thickness

Art.-No. K547 Connecting nut M8 10x58 60 mm post thickness

Art.-No. K548 Connecting nut M8 10x68 70 mm post thickness

Art.-No. K549 Connecting nut M8 10x78 80 mm post thickness

Application: For screwing RICON® double connections (DA).



Inserts RICON® EAR

(Inserts are included with delivery)

Art.-No. K540 Insert M5x14 for RICON® 60/40

Art.-No. K541 Insert M8x18

Application: For special sizes of posts.



RICON® Accessories

Routing-jig for all RICON® sizes

Art.-No. K502 Routing-jig MULTI F40 (plywood)

Advice: The routing-jig MULTI F is suitable for a $\varnothing = 30$ mm guide bush (for plunge router) and a $\varnothing = 15$ mm TCT router cutter.

Application: For milling in case of concealed mounting.



RICON® Accessories

Drilling-jig RICON® EA/DA (galvanized steel)

Art.-No.	K621	K622	K623	K624	K629	K630
	60/40	80/40	100/40	120/40	140/40	160/40

Application: For installation into the drilling-jig and exact pre-drilling of the positioning screws.



HM router cutter

Art.-No. Zo66 HM router cutter Ø = 15, length = 25 mm with Ø = 8 mm shank

Application: To recess the rebate for RICON® and GIGANT.



Stirrup RICON® (stainless spring steel stirrup)

Art.-No. Ko64 Stirrup RICON®

Application: The stirrup locks the connection against slide-in direction. It can be released on request.



Reinforcing plate RICON® (stainless steel)

K530	K531	K532	K533	K534	K535	K536	K537	K538	K539	K519	K523
esco	esco	esco	esco	Gutmann	Gutmann	Gutmann	RAICO	RAICO	RAICO	Schüco	Schüco
RP-tec 50-1	RP-tec 50-1	RP-tec 55-1	RP-tec 55-1	P GF50	P GF60	P GF80	GP 41 und 47	GP 41 und 47	GP 67	GP 50/50	GP 50/60
HA	HA	HA	HA	50 mm*	60 mm*	80 mm*	50 mm*	60 mm*	80 mm*	50 mm*	60 mm*
50 mm*	60 mm*	60 mm*	80 mm*								

Application: The reinforcing plate connects the base aluminium profiles and increases the load capacity of the post and latch connection. The reinforcing plate is available for different base profiles (see table). Reinforcing plates for other profiles on request.

*width of post and latch



Drilling-jig RICON® EA/DA for post-latch connections

Art.-No.	K634	K635	K636	K637	K638	K639
	60/40 Set	80/40	100/40	120/40	140/40	160/40

Drilling-jig RICON® EA/DA for header-joint connections

Art.-No.	K634	K642	K643	K644	K645	K646
	60/40 Set	80/40	100/40	120/40	140/40	160/40

Application: With this the positioning and through-hole drilling are made.



Drilling-jig RICON® with adjustable drilling blocks

Art.-No.	-	K647	K647	K647	K647	K647
Drilling blocks:	-	80/40	100/40	120/40	140/40	160/40

Application: With this the positioning and through-hole drilling are made.

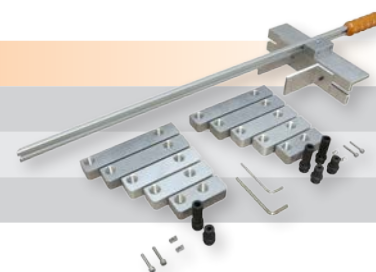

RICON® mounting set

Art.-No. Ko65 Consisting of: 1 RICON®-depth gauge
incl. 1 Torx wrench T25, 1 Allen key SW5

Application: For fine adjustment of RICON® screws.



RICON®

Installation

- Simple and fast installation with spindle moulder or routing machine and optional KNAPP® template.
- Installation with CNC joinery machine possible – all data for the standard CNC joinery machine programs are included.



CNC joinery machine



- 1) With the routing-jig or routing machine on the bolt a 40 mm wide and 12 mm deep milling will be made (Length according to the assembly instructions).



- 2) The drilling-jig will be inserted and pre-drilled.



- 3) Connector parts screw on mirrored.



- 4) The retaining screw is turned up to the shoulder to stop. With the depth gauge the retaining screw is adjusted rationally. Also during the installation process the adjustment of the gap can be guaranteed.



- 5) Assembly: The connection is made by simply pushing together. At this point the locking clip will lock (if fitted).

Stirrup: Depending on static requirements, the stirrup can be inserted on one or on both sides. If the connection is accessible, it can be unlocked (6).



- 6) To unlock the connection, it is necessary to bend up the stirrup in its center eg. with a screwdriver.

Routing dimension RICON®

Width	Length	Depth
40 mm	variable	12 mm

Alternatively, the milling done at a sufficient cross section and in the post - in this case (left), the connector is screwed on the bolt.



Construction manuals, .DXF drawings for RICON®-System as well as your personal consultant in your area, please visit: www.knapp-connectors.com/download

RICON®

Selected reference projects

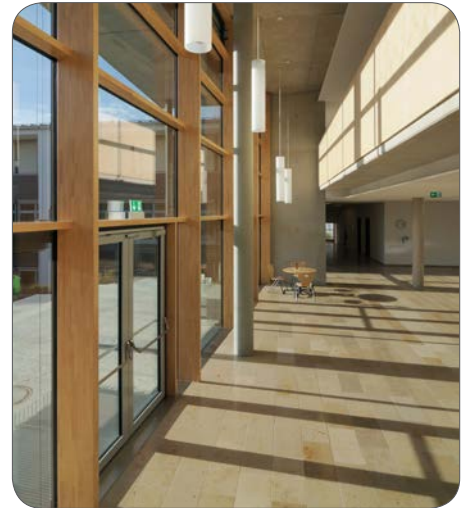

Object: Primary school Feldkirchen/Munich (D), www.schule-feldkirchen.de; **Planner/Architect:** Krug Grossmann Architekten, www.krug-grossmann.de; **Facade:** Vereinigte Holzbaubetriebe Wilhelm Pfalzer & Hans Vogt GmbH & Co KG, www.vhb-memmingen.de



Object: Dietel Bauelemente GmbH (D), www.dietel.de; **Planner:** iproplan Chemnitz, www.iproplan.de; **Senior Architect:** Hans-Jürgen Keinert; **Rough construction:** BAS Scheibenberg, www.bas-scheibenberg.de; **Facade:** Hörmannshofer Fassaden Niederdorf, www.hoermannshofer.de; **Builder and wood-aluminum facade:** Dietel Bauelemente GmbH, www.dietel.de



Object: Office and commercial building „Sunyard“ in Munich (D); **Client:** Deka Immobilien Investment GmbH; **Planner/Architects:** Nickl & Partner Architekten AG, D-80939 Munich, www.nickl-partner.com; **Facade construction:** Lindner Fassaden GmbH, D-94424 Arnstorf, www.lindner-group.com; **Year:** 2012



Contact

+43 (0)664 / 88 51 52 87
 globalsales@knapp-connectors.com
 +49 (0)8122 / 959 41 0
 info@knapp-connectors.com
 knapp-connectors.com/contact



Service

Do you have questions about an optimal solution for your project? Find your sales representative easily on our website:
 knapp-connectors.com/ad



order 24h/24 online-store

You want to order around the clock? Our KNAPP® online-store is open 24h each day.*
 knapp-connectors.com/online-store
 *not available in Austria and Switzerland.



Download

All brochures, data sheets, technical details are downloadable from our web site.
 knapp-connectors.com/download



Concealed | Self-tightening | Demountable



1/2015 | KNAPP®-Brochure | Post-beam-E 01/2015 © The KNAPP® logo is a registered trademark of the trademark owner Knapp GmbH, A-3324 Euratsfeld.

The technical contents in this brochure are valid, until a (on our website for download) new brochure is available. This brochure is the exclusive property of Knapp GmbH. Duplication, reproduction or publication, including excerpts, only with the prior written permission of Knapp GmbH. All calculations given in this brochure are made in subject to any printing and typing errors and other mistakes. Technical drawings and calculations, especially those affecting the statics, on customer's own responsibility. Any calculations and drawings in this respect by the company Knapp GmbH are subject to proposals for the orientation and / or liability for the accuracy and therefore not free the customer to wear it even for a proper drawing and calculation by a professional concern. Picture credits are available and can be requested if required. All rights reserved. Copyright © 2014 by Knapp GmbH.



Knapp GmbH | Wassergasse 31 | A-3324 Euratsfeld | Tel.: +43 (0)7474 / 799 10 | Fax: +43 (0)7474 / 799 10 99

Knapp GmbH Niederlassung Deutschland | Katharina-Fischer-Platz 1 | D-85435 Erding
 Tel.: +49 (0)8122 / 959 41 0 | Fax: +49 (0)8122 / 959 41 10 | E-Mail: info@knapp-connectors.com

KNAPP®
 connectors.com