

Connecting systems

for timber construction, wood curtain and prefabricated walls

Connecting Your Ideas ...



Grunder & Geschule © Krogmann.



KNAPP[®]
connectors.com

Innovative
solutions
Made in Austria
Family Business
since 1983
Your business
partner for
timber frame
mass timber
constructions
or curtain and
prefabricated
walls

RICON® S
patented by KNAPP®

RICON® S, RICON® S, patented by KNAPP®
Adjustable collar bolt version for tolerance
compensation up to 5 mm.

Universal timber construction connector
with adjustable collar bolt, designed and
developed for timber construction





Since our establishment in 1986, our family-owned business has been committed to pioneering innovative connectors for timber construction. We pride ourselves on using sustainable and, when possible, renewable materials, ensuring easy assembly and disassembly. At Knapp Connectors, we've long championed the circular principle, even before its widespread recognition.

In the ever-evolving landscape of architecture, durability, sustainability, and adaptability are paramount. Structures need to be resilient, environmentally friendly, and capable of being repurposed or reused. This requires connection systems that can seamlessly integrate with the principles of circular construction.

With this vision in mind, we've meticulously crafted a diverse range of connection systems tailored to meet the demands of timber and structural engineering. Our solutions offer innovative, sustainable, and circular approaches to various construction challenges.

Knapp Connectors are renowned for their easy prefabrication assembly, quick on-site installation, and hassle-free disassembly. They are not only reusable but also recyclable and can be upcycled, allowing for flexible modification, disassembly, and reconstruction as needed. Our materials are of the highest quality, boasting longevity, and some are even partly or wholly composed of renewable resources, like our Mateo timber nail.

At Knapp, we aim to be the trusted partner for architects and engineers looking to incorporate sustainable and resilient practices into their projects while ensuring long-term viability. We take pride in the diverse range of projects our valued customers have undertaken using our connectors.

At Knapp, we aim to be the trusted partner for architects and engineers looking to incorporate sustainable and resilient practices into their projects while ensuring long-term viability. We take pride in the diverse range of projects our valued customers have undertaken using our connectors.

We're excited to share our new brochure and website, showcasing our wide array of both familiar and innovative connection systems, accompanied by numerous inspirational references. Our aim is to provide you with detailed insights and practical guidance for your construction needs.

Explore our product range, including RICON, GIGANT, WALCO, RICON S, MEGANT by T-JOINT, and MATEO, and join us in our commitment to staying ahead of industry trends. At Knapp Connectors, we're here to support you at every step of your construction journey.

Best regards,

Friedrich Knapp and Family.

Table of contents



3	Editorial
Welcome !	03



6	Information
The history of KNAPP® connectors	06



8	Wood connectors overview
Application areas and types of wood	08
Overview loads for connector types	09



12	Planning, R&D service
Planner service, dimensioning tools, DC-Statik	



13	RICON® inox
Connectors for post-beam and main-secondary beam connections	14
Overview single connection - EA	15
Variantes DA / EAR, vis and accessoires	20





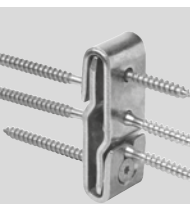







21	RICON®
Connectors for post-beam and main-secondary beam connections	22
Overview single connection - EA	25
Performance values for post-beam connections on wood curtain wall	28
Overview DA/EAR connectors, screws and accessories	29
Wood to steel and wood to concrete connections	31
Connection types and fire rating	34















37	GIGANT
Connectors for main/secondary beams and pillars connections	38
Wood to concrete connections	42
Wood to steel connections	44
Screws, locking clip and accessories	46



47	RICON® S
Connectors for mass timber construction	48
Connectors with welded collar bolt	52
Connectors with adjustable collar bolt	67
Connectors with adjustable collar bolt and insert screw	71
Connectors with screwed collar bolt	75
Connectors with spring-loaded collar bolt	79
Wood to steel connections	84
Wood to concrete connections	85

MEGANT®	89	
The heavy-duty connectors for mass timber construction	90	
Overview	91	
Wood to steel and wood to concrete connections	92	
Fire rating	94	
Connector sizes and technical details	97	
<hr/>		
WALCO® Z	109	
Timber wall connectors for prefabricated walls and modular building WALCO® Z40 WALCO® Z32	110	
WALCO® V	115	
Connecting systems for prefabricated WALCO® V60 WALCO® V80 WALCO® V oblong	116	
WALCO®	127	
Connectors for facade and modular building WALCO® 60 WALCO® 80	128	
WALCO® BOLT	133	
Anchoring system for cladding walls and modular building WALCO® BOLT A130 WALCO® BOLT B130 WALCO® BOLT C130	134	
WALCO® PIPE	141	
Anchoring system for cladding walls and modular building WALCO® PIPE	142	
WALCO® L and T	147	
Anchoring solutions for timber walls WALCO® L WALCO® T	148	
<hr/>		
T-JOINT	153	
Angled cylinder connectors for bending-resistant frame corners and diagonal screw connection: T-JOINT D20 D30 D35 D40	154	
<hr/>		
ZIPBOLT®	160	
Post anchor for staircases, verandas, terraces and balconie Zipbolt™ UT Post Anchor Zipbolt™ XT Post Anchor	160	
<hr/>		
MATEO	161	
Timber peg connector made of solid hardwood MATEO Ash MATEO Beech	162	
<hr/>		
QUATRO, Z-DECK	165	
Outdoor connectors QUATRO Z-DECK Exterior Slipfix UNO30 DUO 30 inox KNAPP® Dowel	165	

Guiding symbols: you will find the following symbols for orientation with each type of connector.

 Wood to wood connection	 Visible	 Fire-resistance rating	 Assembly every side-by-side
 Wood to steel connection	 Concealed	 Assembly from below	 Assembly 3 or 4 sided
 Wood to concrete connection	 Allow prefabrication in workshop	 Assembly from above	 Certifications

KNAPP® - The main and secondary beams connecting revolution

KNAPP® connectors for future-oriented timber construction and engineered timber construction

We are the Austrian manufacturer and supplier for innovative connecting systems in timber construction and timber engineering. We offer with GIGANT, RICON®, WALCO® V, RICON® S, MEGANT® and T-JOINT a whole range of efficient connecting systems.

All connecting systems have the European Approval (ETA) with CE marking, for many types of wood and modern wood materials and are externally monitored.

Architects, planners and manufacturers have the security of a European approved connecting system, which even meets the Swiss national building regulations.



Connecteur MEGANT®

The revolution

More than 20 years ago, we revolutionised end-grain fastening systems with, at the time, the only mechanical connector designed for main and secondary beams. We named it GIGANT and were the first on the European market to get German building approval for this field.

Tested, patented and approved

The proven and patented KNAPP® connecting systems can bear loads in all directions providing therefore the utmost safety and perfect functionality.

PROGRESSIVE TIMBER CONSTRUCTION CONNECTORS

Invisible connection for high loads

The RICON® S connectors extend the innovative product range and enable invisible and fast connections for loads up to 230 kN.

Heavy duty applications up to 768 kN are covered by the MEGANT® connectors.

High degree of prefabrication in house construction

The WALCO® V system has been designed for connecting timber walls in prefabricated houses and, like all KNAPP® timber connectors, can be structurally calculated. Connections are possible to wood, steel, concrete and masonry. The greatest advantage of the WALCO® V connector is enabling the whole precast wall production in the factory followed by a precise and fast

assembly on site, preventing potential hazards on the construction site. Another advantage of the WALCO® V system is that wall openings, as required with conventional screw connections, are no longer needed.

This has the effect of a significantly tighter wall in direct comparison. Over the time, the system has been complemented by variable base plates for modular and facade walls and now with the new wall to floor anchor WALCO® L and T.

Product innovations

The T-JOINT angled cylinder connects perfectly rigid frame corners and tension joints by means of a transverse screw connection and is ideal for assembling carports.

The MATEO wooden nail is used in ecological house construction.

Analysis and Planner service

We offer a planning and dimensioning service to planners, structural engineers and architects.

You have the choice between an interactive load table, a dimensioning tool and a DC-Statik manufacturer's version of Dietrich's to create a pre-dimensioning yourself and our customized calculation service by our engineers.











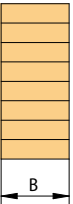
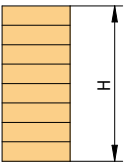
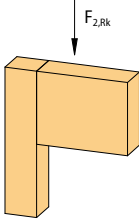









Only close cooperation during the planning phase guarantees the efficient realisation of all projects. All timber construction connectors are available directly from KNAPP® or from selected sales partners and dealers.

BEAM HANGER SELECTION OVERVIEW (all RICON® ranges)

Pre-selection tool for using KNAPP® connectors on glulam beams GL24h

The overview allows a quick identification of the suitable KNAPP® connectors. The table shows the permissible loads for each system in relation to the minimum cross-section of the beam.

For more information on each connector, please refer to the pages indicated in the right-hand column of the table. Parameters such as geometry and special connections must be checked.

Min. beam width	Min. beam height	Characteristic load bearing capacities $F_{2,Rk}$ [kN]								
										
mm	mm	0	5	10	15	20	Connectors	Art.-No.	Page	
30	86							RICON® inox 66/16	K267	15
30	90							RICON® inox 70/20	K271	15
38	120							RICON® inox 100/25	K268*	–
	140							RICON® inox 120/25	K272	16
	160							RICON® inox 140/25	K269*	–
	180							RICON® inox 160/25	K273	16
50	60							RICON® inox 40/40	K378	19
	80							RICON® 60/40	K360	25
	80							RICON® inox 60/30	K274	17
	100							RICON® 80/40	K361	25
	100							RICON® inox 80/30	K275	17
	100							RICON® inox 80/40	K372	19
	120							RICON® 100/40	K362	26
	120							RICON® inox 100/30	K276	17
	140							RICON® 120/40	K363	26
	140							RICON® inox 120/30	K277	18
	160							RICON® 140/40	K365	27
	160							RICON® inox 140/30	K278	18
180							RICON® inox 160/30	K279	18	
180							RICON® inox 160/40	K376	19	
180							RICON® 160/40	K364	27	

* These RICON® stainless steel connectors are only available on request, for further information please contact our consultants directly.

References



CONNECTEURS CONSTRUCTION BOIS

Pre-selection tool for using KNAPP® connectors on glulam beams GL24h

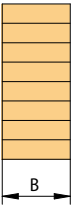
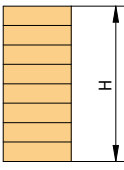
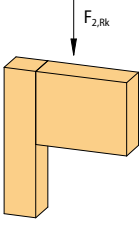
Min. beam width	Min. beam depth	Characteristic connection load $F_{2,Rk}$ [kN]												
														
mm	mm	0	100	200	300	400	500	600	700	800	900	Connectors	Art.-No.	Page
60	150	12,5										GIGANT 120/40	K051	39
	200	16,7										GIGANT 150/40	K050	40
	200	19,2										GIGANT 150/40 max ¹	K050	40
	220	25										GIGANT 180/40	K052	41
	220	30,7										GIGANT 180/40 max ²	K052	41
100	150	37,1										RICON®S 140/60 VS	K126	52
	200	40,2										RICON®S 140/60 VS max ³	K126	52
	200	56,7										RICON®S 200/60 VS	K127	55
	220	66,5										RICON®S 200/60 VS max ⁴	K127	55
	220	96,8										MEGANT® 310/60/40	K242	97
	520	152,1										MEGANT® 430/60/40	K243	98
	640	177,7										MEGANT® 550/60/40	K244	99
120	230	79										RICON®S 200/80 VS	K128	58
	480	92,4										RICON®S 200/80 VS max ⁵	K128	58
	320	118,1										RICON®S 290/80 VS	K129	61
	560	142,7										RICON®S 290/80 VS max ⁶	K129	61
	720	170,6										RICON®S 390/80 VS+ZP	K191	64
	800	195,3										RICON®S 390/80 VS+ZP max ⁷	K191	64
	800	195,3										MEGANT® 310/100/40	K239	100
140	440	124,5										MEGANT® 430/100/40	K240	101
	520	207,4										MEGANT® 550/100/40	K241	102
	640	235,2										MEGANT® 310/150/50	K197	103
190	400	156										MEGANT® 430/150/50	K220	104
	520	260										MEGANT® 550/150/50	K221	105
	640	364										MEGANT® 610/150/50	K270	106
	710	416										MEGANT® 730/150/50	K251	107
	830	443,2										MEGANT® 1030/150/50 SL	K180	108
	1130	768												

Screw connection alternatives (for higher load bearing capacities)

¹ GIGANT 150x40 max with 4 CS-screws 10x200 in secondary beam² GIGANT 180x40 max with 6 CS-screws 10x200 in secondary beam³ RICON®S 140x60 VS max with 10 CS-screws 8x240 in secondary beam⁴ RICON®S 200x60 VS max with 16 CS-screws 8x240 in secondary beam⁵ RICON®S 200x80 VS max with 16 CS-screws 10x300 in secondary beam⁶ RICON®S 290x80 VS max with 25 CS-screws 10x300 in secondary beam⁷ RICON®S 390x80 VS+ZP max with 28 CS-screws 10x300 in secondary beam

RICON® S range

RICON®S EK GK - Pre-selection tool for using KNAPP® connectors on glulam beams GL24h

Min. beam width	Min. beam depth	Characteristic connection load $F_{2,Rk}$ [kN]			Connectors	Art.-No.	Page
mm	mm	0	100	180			
100	160	31,5			RICON®S 140/60 VK	K130	75
	260	33,5			RICON®S 140/60 VK max ⁸	K130	75
	220	34,9			RICON®S 200/60 VK	K132	76
	160	37,1			RICON®S 140/60 EK	K146	67
	160	37,1			RICON®S 140/60 GK	K134	79
	160	40,2			RICON®S 140/60 EK max ⁹	K146	57
	160	40,2			RICON®S 140/60 GK max ⁹	K134	79
	220	41,4			RICON®S 200/60 VK max ¹⁰	K132	76
	220	44,2			RICON®S 200/60 EK	K148	68
	220	44,2			RICON®S 200/60 GK	K136	80
	120	230	48,8			RICON®S 200/80 VK	K138
320		48,8			RICON®S 290/80 VK	K141	78
230		58,4			RICON®S 200/80 VK max ¹¹	K138	77
320		59,7			RICON®S 290/80 VK max ¹²	K141	76
230		65,0			RICON®S 200/80 EK	K153	69
230		65,0			RICON®S 200/80 GK	K142	81
320		72,2			RICON®S 290/80 EK	K156	70
320		72,2			RICON®S 290/80 GK	K145	82

Screw connection alternatives (for higher load bearing capacities)

⁸ RICON®S 140x60 VK max with 8 CS-screws 8x240 in secondary beam

⁹ RICON®S 140x60 EK/GK max with 10 CS-screws 8x240 in secondary beam

¹⁰ RICON®S 200x60 VK max with 8 CS-screws 8x240 in secondary beam

¹¹ RICON®S 200x80 VK max with 9 CS-screws 10x300 in secondary beam

¹² RICON®S 290x80 VK max with 9 CS-screws 10x300 in secondary beam

WALCO® range

Pre-selection tool for using KNAPP® connectors on glulam beams GL24h

Min. wood width	Min. wood thickness	Characteristic connection load $F_{2,Rk}$ [kN]			Connectors	Art.-No.	Page
mm	mm	0	5	10	15		
80	60	5,9			WALCO® V60 KS	K701	130
	60	4,8			WALCO® V60 EH	K704	130
	60	4,9			WALCO® V60 VK	K700	130
	60	8,6			WALCO® V60 GH	K702	130
100	60	7,1			WALCO® V80 KS	K711	131
	60	6,5			WALCO® V80 EH	K713	131
	60	6,2			WALCO® V80 VK	K710	131
	60	16,0			WALCO® V80 GH	K712	131
100 x 48	60 x 48	9,0			WALCO® Z32 (C24)	K078	113
100 x 60	60 x 60	10,80			WALCO® Z40 (C24)	K072	109



Planner service

Dimensioning for all connections

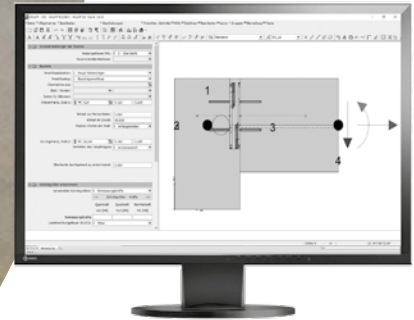

We help you to realise more projects in less time!
We offer a comprehensive planning and calculation service, especially for architects, planners and wood builders.

- KNAPP® DC-Statik design software
- Online dimensioning tool
- Interactive load capacity tables
- Custom planning service

You can find all the information on our website under Design Service. Close cooperation during the planning phase guarantees optimal implementation of your projects.

Partner software

Recommended partner software for interfacing to machine processing:



We now offer our KNAPP® DC-Statik design software. KNAPP® DC-Statik is available for the connector products MEGANT®, GIGANT, RICON®, RICON® S and RICON® stainless steel. With this software you can easily create verifiable documents and calculate your projects safely! You can download the programme free of charge.



The timber construction and wall connectors are implemented and available in the DataStore of SEMA. The SEMA user is able to download the master data for the KNAPP® connection systems in the SEMA programme. The master data of the KNAPP® fasteners are easily accessible in the SEMA DataStore via the DataStore button. These are available in the languages German, English and French.



2D structural elements and their connection nodes are calculated with the structural analysis software from Wallner Mild und Dietrich structural analysis software. The connection nodes can be dimensioned with the Knapp connectors RICON®, GIGANT®, RICON®S and MEGANT®.



PLANNER SERVICE

Wood connector

Made of A2 stainless steel with
usage classification 3
Connecting up to 17,4 kN*

- | Minimum timber width up from 30 mm
- | Multiple disassembly and reassembly possible
- | Prefabrication in factory
- | Flexible installation from the outside and inside
- | Joint can be adjusted to correct possible tolerances
- | Secure connection with locking clip
- | Available as single and double connection

RICON® inox

Available in 13 sizes and 3 versions.

The values only apply when used with original KNAPP® screws! Design values are available on our website under Planer Service.

* Characteristic value $F_{2,Rk}$ in slide-in direction according to ETA 10/0189 (2022/08/25), for glulam GL24h.



RICON® inox

- Applications: visible and concealed connections
- Connections: Steel, concrete, wood materials and special wood species. e.g. oak, Douglas fir, larch and impregnated woods (Accoya)
- Indoor and outdoor applications: garden furniture, balcony, terrace roofing, carport, playgrounds and sports equipments, pergola and other structures in service class 1 to 3.



Corrosion resistance class 2 - Outdoors for pergolas, balconies, playground equipment and special types of wood.

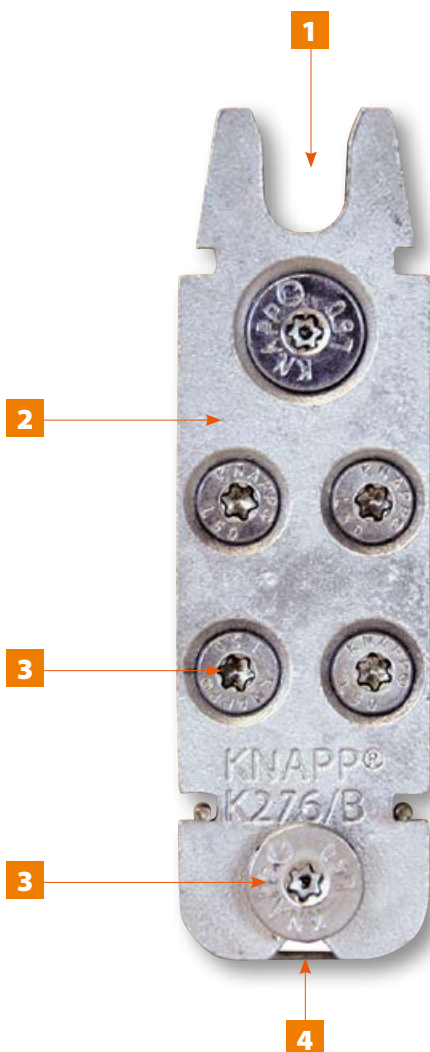

- 1 The dovetail shape ensures optimum reception of the RICON® stainless steel retaining CS-screws. The short clamping distance makes it easy to hook in, while engaging the plates, ensuring tightness and fast assembly of the elements.
- 2 RICON® consists of two identical plates made of A2 inox (stainless steel). Inox screws and locking clip are included.
- 3 Ø 5 mm and Ø 8 mm RICON® CS-screws have a reinforced shank and collar for optimum strength and grip.
- 4 The stainless spring steel locking clip can be installed into the locating slots prior to final assembly. It locks the connection against the slide-in direction and can be disassembled if needed.

Fire rating: Fire resistance (EN 1995-1-2) through 3-4 sided concealed, joint-tight installation (R30 ≥ 28 mm, R60 ≥ 49 mm)



RICON® inox 66/16

(Dimensions in mm)

Minimum timber cross section

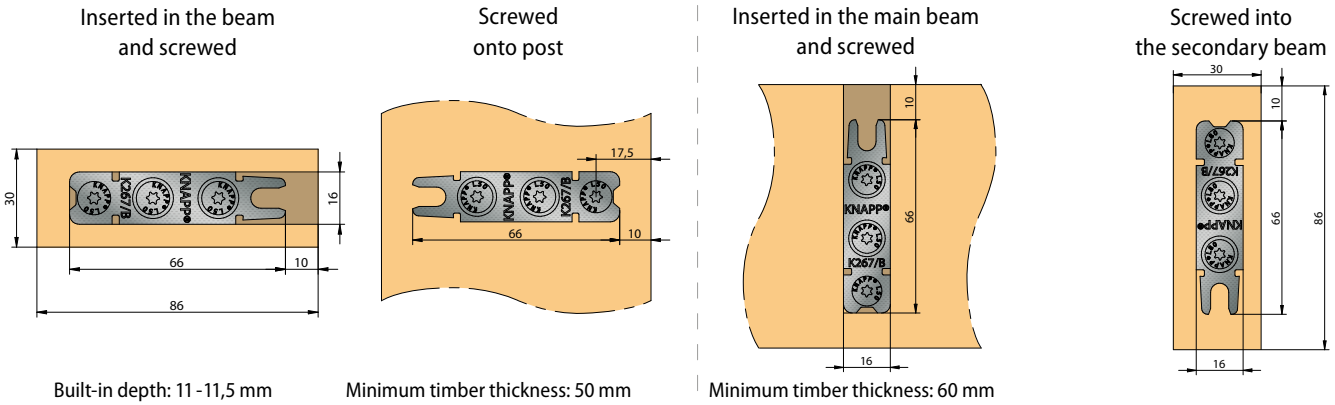

Built-in depth: 11 - 11,5 mm

Minimum timber thickness: 50 mm

Minimum timber thickness: 60 mm

RICON® 66/16 inox - single connection (EA)

Art.-No. K267

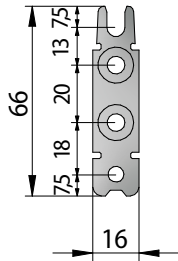

RICON® inox	Connection	Screw connection		Charact. charge. [GL24h] C.SER.1*	
		Joist	Header	F _{1,RK} [kN]	F _{2,RK} [kN]**
66/16	EA	3 CS 5x80	3 CS 5x50	3.5	4.8
1 locking clip: F _{3,RK} = 1,0 kN			2 locking clips: F _{3,RK} = 2,0 kN		

Minimum timber cross section: 30 x 86 mm

* Homogeneous glulam - indoor

Alternative screws: **load varies.

3 CS-screws 5x25

3 CS-screws 5x30

3 CS-screws 5x50

3 CS-screws 5x60

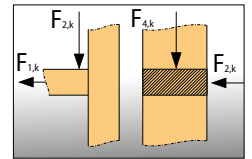

RICON® inox 70/20

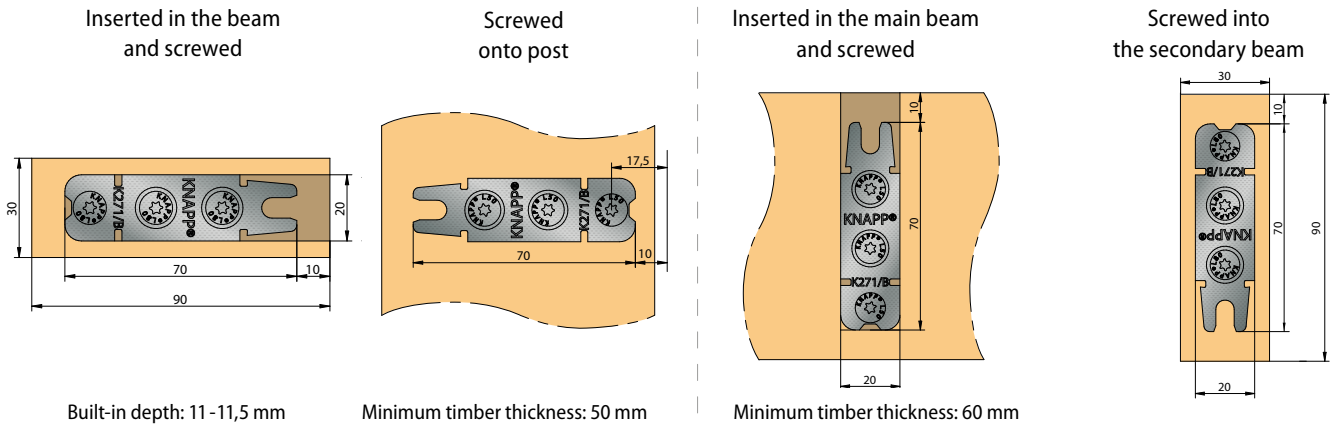

Built-in depth: 11 - 11,5 mm

Minimum timber thickness: 50 mm

Minimum timber thickness: 60 mm

RICON® 70/20 inox - single connection (EA)

Art.-No. K271

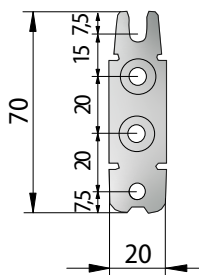

RICON® inox	Connection	Screw connection		Charact. charge. [GL24h] C.SER.1*	
		Joist	Header	F _{1,RK} [kN]	F _{2,RK} [kN]**
70/20	EA	3 CS 5x80	3 CS 5x50	3.5	4.8
1 locking clip: F _{3,RK} = 1,0 kN			2 locking clips: F _{3,RK} = 2,0 kN		

Minimum timber cross section: 30 x 90 mm

* Homogeneous glulam - indoor

Alternative screws: **load varies.

3 CS-screws 5x25

3 CS-screws 5x30

3 CS-screws 5x50

3 CS-screws 5x60

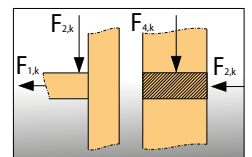

RICON® inox 25

(Dimensions in mm)

Minimum timber cross section

Inserted in the beam and screwed

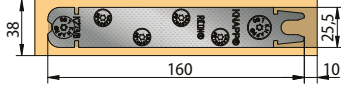

Built-in depth: 11 - 11,5 mm

Screwed onto post

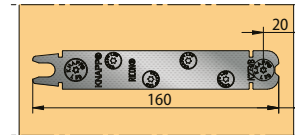

Minimum timber thickness: 50 mm

Inserted in the main beam and screwed

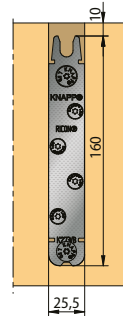

Minimum timber thickness: 60 mm

Screwed into the secondary beam

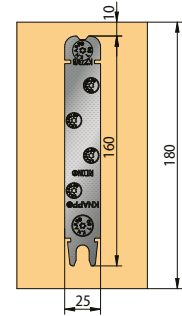

RICON® inox series 25

RICON® 120/25 inox - single connection (EA)

Art.-No. K272

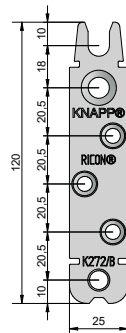

RICON® inox	Connection	Screw connection		Charact. charge. [GL24h] C.SER.1*	
		Joist	Header	F _{1,RK} [kN]	F _{2,RK} [kN]
120/25	EA	2 CS 8x80 3 CS 5x80	2 CS 8x50 3 CS 5x50	4.4	8.9
1 locking clip: F _{3,RK} = 1,0 kN			2 locking clips: F _{3,RK} = 2,0 kN		

Minimum timber cross section: 38 x 140 mm

* Homogeneous glulam - indoor

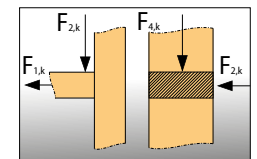

RICON® 160/25 EA inox - single connection (EA)

Art.-No. K273

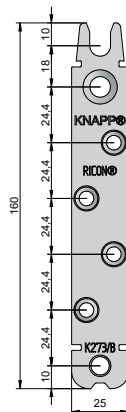

RICON® inox	Connection	Screw connection		Charact. charge. [GL24h] C.SER.1*	
		Joist	Header	F _{1,RK} [kN]	F _{2,RK} [kN]
160/25	EA	2 CS 8x80 4 CS 5x80	2 CS 8x50 4 CS 5x50	4.4	10.4
1 locking clip: F _{3,RK} = 1,0 kN			2 locking clips: F _{3,RK} = 2,0 kN		

Minimum timber cross section: 38 x 180 mm

* Homogeneous glulam - indoor

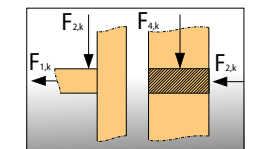

RICON® references



Post-beam wood-glass curtain wall
Primary school, Germany

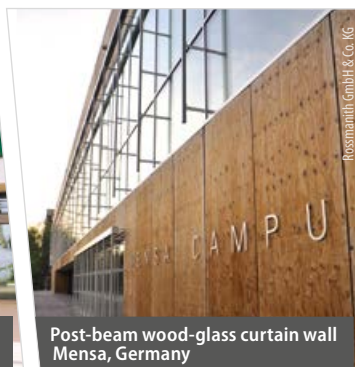

Post-beam wood-glass curtain wall
Mensa, Germany



Post-beam timber construction
Winter garden, Germany



Post-beam timber construction
Winter garden, Austria

RICON® inox 30

(Dimensions in mm)

Minimum timber cross section

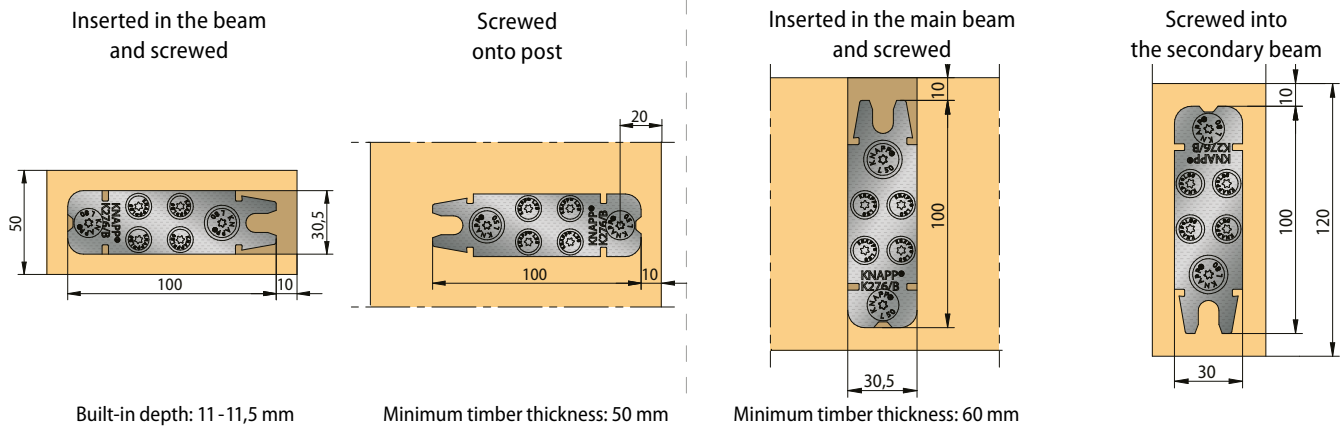

Built-in depth: 11 - 11,5 mm

Minimum timber thickness: 50 mm

Minimum timber thickness: 60 mm

RICON® inox 30

RICON® 60/30 EA inox - single connection (EA)

Art.-No.K274

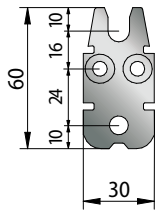
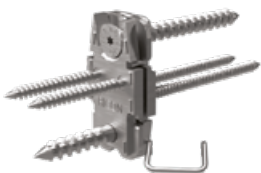

RICON® inox	Connection	Screw connection		Charact. charge. [GL24h] C.SER.1*	
		Joist	Header	F _{1,RK} [kN]	F _{2,RK} [kN]
60/30	EA	2 CS 5x80 1 CS 8x80	2 CS 5x50 1 CS 8x50	4.4	5.2
		1 locking clip: F _{3,RK} = 1.9 kN		2 locking clips: F _{3,RK} = 3.8 kN	

Minimum timber cross section: 50 x 80 mm

* Homogeneous glulam - indoor

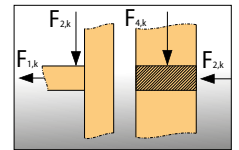

RICON® 80/30 EA inox - single connection (EA)

Art.-No.K275

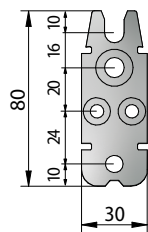

RICON® inox	Connection	Screw connection		Charact. charge. [GL24h] C.SER.1*	
		Joist	Header	F _{1,RK} [kN]	F _{2,RK} [kN]
80/30	EA	2 CS 8x80 2 CS 5x80	2 CS 8x50 2 CS 5x50	4.4	7.5
		1 locking clip: F _{3,RK} = 1.9 kN		2 locking clips: F _{3,RK} = 3.8 kN	

Minimum timber cross section: 50 x 100 mm

* Homogeneous glulam - indoor

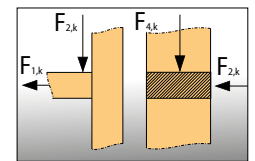

RICON® 100/30 EA inox - single connection (EA)

Art.-No.K276

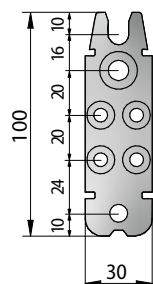

RICON® inox	Connection	Screw connection		Charact. charge. [GL24h] C.SER.1*	
		Joist	Header	F _{1,RK} [kN]	F _{2,RK} [kN]
100/30	EA	2 CS 8x80 4 CS 5x80	2 CS 8x50 4 CS 5x50	4.4	10.4
		1 locking clip: F _{3,RK} = 1.9 kN		2 locking clips: F _{3,RK} = 3.8 kN	

Minimum timber cross section: 50 x 120 mm

* Homogeneous glulam - indoor

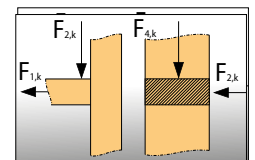

(Dimensions in mm)

RICON® 120/30 EA inox - single connection (EA)

Art.-No.K277

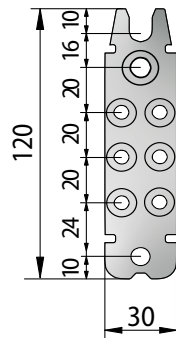

RICON® inox	Connection	Screw connection		Charact. charge. [GL24h] C.SER.1*	
		Joist	Header	F _{1,Rk} [kN]	F _{2,Rk} [kN]
120/30	EA	2 CS 8x80 6 CS 5x80	2 CS 8x50 6 CS 5x50	4.4	13.2
1 locking clip: F _{3,Rk} = 1.9 kN			2 locking clips: F _{3,Rk} = 3.8 kN		

Minimum timber cross section: 50 x 140 mm

* Homogeneous glulam - indoor

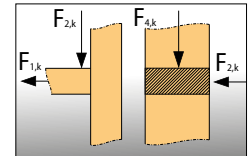
**RICON® 140/30 EA inox - single connection (EA)**

Art.-No.K278

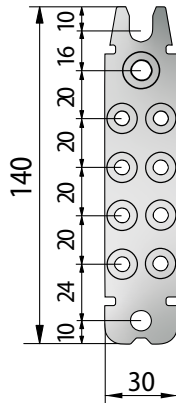

RICON® inox	Connection	Screw connection		Charact. charge. [GL24h] C.SER.1*	
		Joist	Header	F _{1,Rk} [kN]	F _{2,Rk} [kN]
140/30	EA	2 CS 8x80 8 CS 5x80	2 CS 8x50 8 CS 5x50	4.4	16.1
1 locking clip: F _{3,Rk} = 1.9 kN			2 locking clips: F _{3,Rk} = 3.8 kN		

Minimum timber cross section: 50 x 160 mm

* Homogeneous glulam - indoor

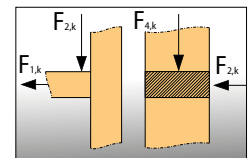
**RICON® 160/30 EA inox - single connection (EA)**

Art.-No.K279

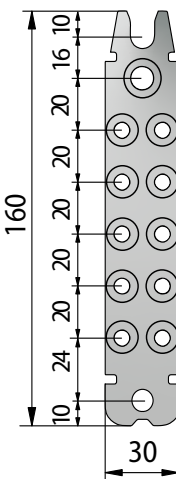

RICON® inox	Connection	Screw connection		Charact. charge. [GL24h] C.SER.1*	
		Joist	Header	F _{1,Rk} [kN]	F _{2,Rk} [kN]
160/30	EA	2 CS 8x80 10 CS 5x80	2 CS 8x50 10 CS 5x50	4.4	17.4
1 locking clip: F _{3,Rk} = 1.9 kN			2 locking clips: F _{3,Rk} = 3.8 kN		

Minimum timber cross section: 50 x 180 mm

* Homogeneous glulam - indoor

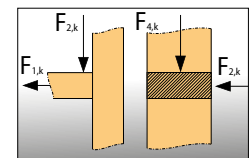
**Installing RICON® inox - Main-secondary beam connection type**

Mill with with routing-jig



Pre-drill and screw



Assemble



Secured connection using a locking clip

RICON® inox 40

(Dimensions in mm)

Minimum timber cross section

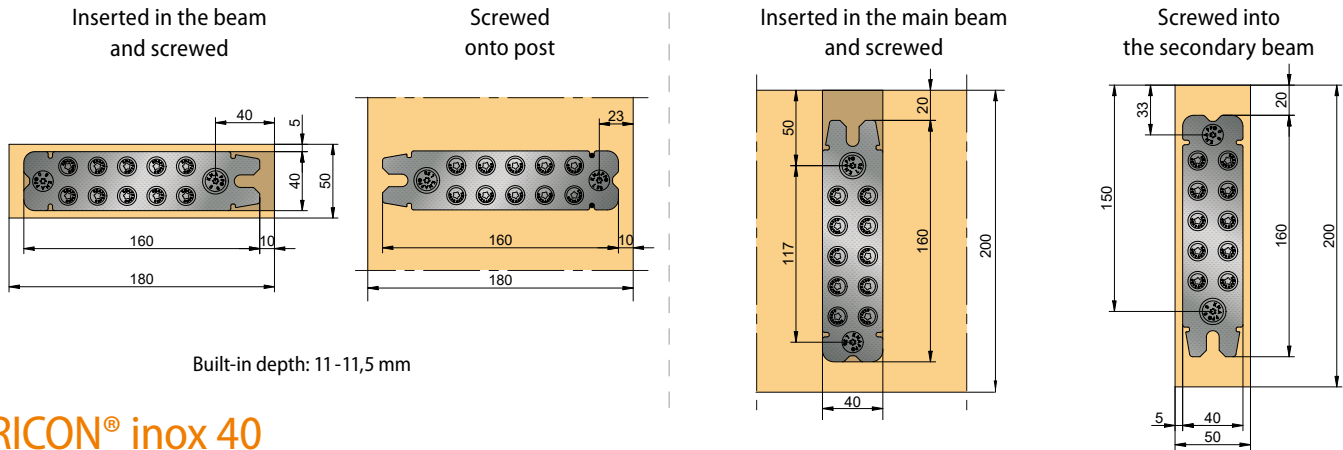

Built-in depth: 11-11,5 mm

RICON® inox 40

RICON® 40/40 EA inox - single connection (EA)

Art.-No.K378

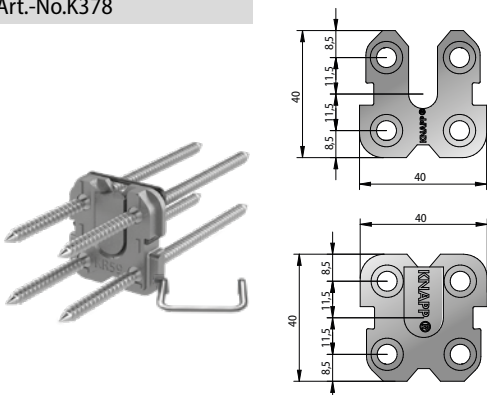

RICON® inox	Connection	Screw connection		Charact. charge. [GL24h] C.SER.1*	
		Joist	Header	F _{1,RK} [kN]	F _{2,RK} [kN]
40/40	EA	4 CS 5x80	4 CS 5x50	7.5	4.0
1 locking clip: F _{3,RK} = 2.7 kN			2 locking clips: F _{3,RK} = 5.4 kN		

Minimum timber cross section: 50 x 60 mm

* Homogeneous glulam - indoor

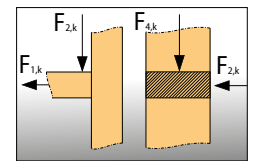

RICON® 80/40 EA inox - single connection (EA)

Art.-No.K372

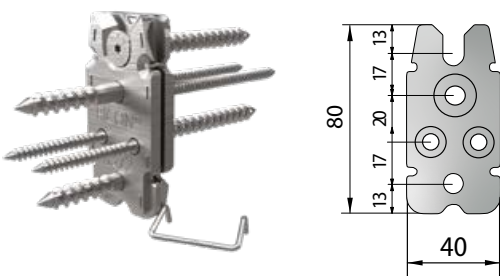

RICON® inox	Connection	Screw connection		Charact. charge. [GL24h] C.SER.1*	
		Joist	Header	F _{1,RK} [kN]	F _{2,RK} [kN]
80/40	EA	2 CS 8x80 2 CS 5x80	2 CS 8x50 2 CS 5x50	4.4	7.5
1 locking clip: F _{3,RK} = 2.7 kN			2 locking clips: F _{3,RK} = 5.4 kN		

Minimum timber cross section: 50 x 100 mm

* Homogeneous glulam - indoor

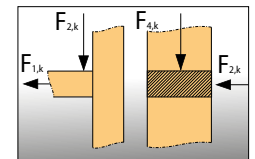

RICON® 160/40 EA inox - single connection (EA)

Art.-No.K376

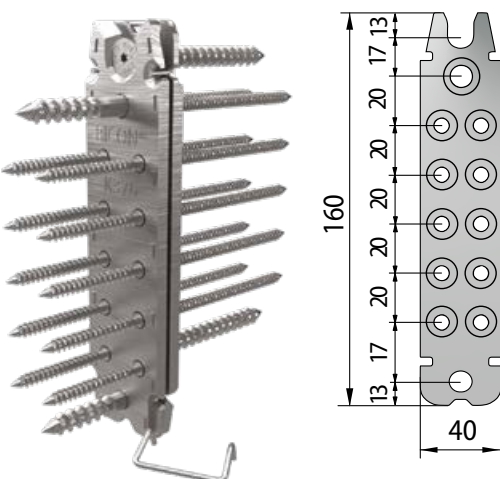

RICON® inox	Connection	Screw connection		Charact. charge. [GL24h] C.SER.1*	
		Joist	Header	F _{1,RK} [kN]	F _{2,RK} [kN]
160/40	EA	2 CS 8x80 10 CS 5x80	2 CS 8x50 10 CS 5x50	4.4	17.4
1 locking clip: F _{3,RK} = 2.7 kN			2 locking clips: F _{3,RK} = 5.4 kN		

Minimum timber cross section: 50 x 180mm

* Homogeneous glulam - indoor

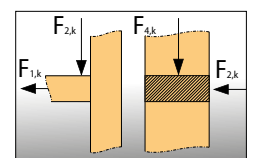

RICON® inox DA and EAR for all sizes

Double connection with connecting nuts and RICON® inox CS-screws (available upon request)

Single or double connection with inserts and RICON® inox CS-screws (available upon request)

DA

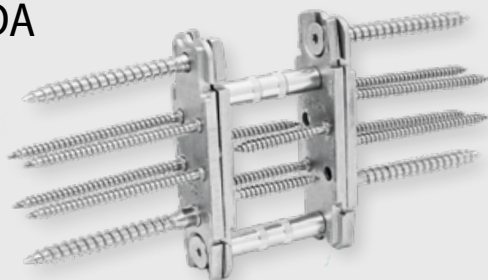

EAR



RICON DA



RICON EAR

RICON® inox screws

RICON® Self-tapping CS-screws with reinforced shaft
(delivery includes CS-screws with the matching RICON® connectors)

Art.-No. Z950

Inox A2 CS-screws 5x50



Art.-No. Z953

Inox A2 CS-screws 8x50



Application: to screw the RICON® inox plate into the side grain of main beam/post.



Art.-No. Z952

Inox A2 CS-screws 5x80



Art.-No. Z954

Inox A2 CS-screws 8x80



Application: to screw the RICON® inox plate into the side grain of secondary beam/latch.



RICON® inox DA - EAR CS-screws

Art.-No. Z955

Inox A2 CS-screws M5x16 (for RICON® 60/40 DA)



Art.-No. Z956

Inox A2 CS-screws M8x18 (for RICON® DA and EAR)



Application: to mount RICON® plate in a cross joint double connector (DA or EAR).



RICON® DA connecting nuts

(delivery includes connecting nuts with the matching RICON® connectors)

Art.-No. K540

Connecting nut M5 8x48

50 mm post thickness

Art.-No. K541

Connecting nut M5 8x53

55 mm post thickness

Art.-No. K542

Connecting nut M5 8x58

60 mm post thickness

Art.-No. K543

Connecting nut M5 8x78

80 mm post thickness



Application: to mount RICON® inox 60/40 double connector (DA).

Art.-No. K544

Connecting nut M8 10x36

<50 mm post thickness

Art.-No. K545

Connecting nut M8 10x48

50 mm post thickness

Art.-No. K546

Connecting nut M8 10x53

55 mm post thickness

Art.-No. K547

Connecting nut M8 10x58

60 mm post thickness

Art.-No. K548

Connecting nut M8 10x68

70 mm post thickness

Art.-No. K549

Connecting nut M8 10x78

80 mm post thickness



Application: to mount RICON® and RICON® inox bigger sizes double connectors (DA).

Insert RICON® inox EAR

(delivery for connecting nuts with the matching RICON® connectors are available upon request)

Art.-No. Z540

Insert M5x14 for RICON® 60/40

Art.-No. Z541

Insert M8x18



Application: to mount unique applications and post sizes.

Connector for curtain walls

Connecting post-beam curtain walls
up to 700 kg as glass load and
main to secondary beam
up to 23 kN* as vertical load

- Minimum timber width up from 50 mm
- Can be assembled and disassembled at will, repeatedly
- High degree of prefabrication in factory for fast and precise assembly on site
- Elements are assembled on site without the need for any further screw fastening
- Later adjustment of gap between joints
- Compensating for structural tolerances
- Application also permitted on interlayer
- For 90°-45° screw connection along the grain

RICON®

Available in 6 sizes and 3 versions.

The values only apply when used with original KNAPP® screws! Design values are available on our website under Planer Service.

* Characteristic value $F_{2,Rk}$ in slide-in direction according to ETA 10/0189 (2022/08/25), for hardwood D30 (e.g. oak).



RICON®

- Applications: concealed post-beam and main-secondary beam connections
- Connections: wood materials e.g. laminated veneer lumber (Kerto®), BauBuche, hardwoods, steel and concrete
- Areas of application: aluminum-wood-glass curtain wall, winter garden, canopy, pergola, timber frame construction in service class 1 and 2.



Installation example: RICON® Mensa Schloss Holte

© Dietel
©Hecker-System Holzbau

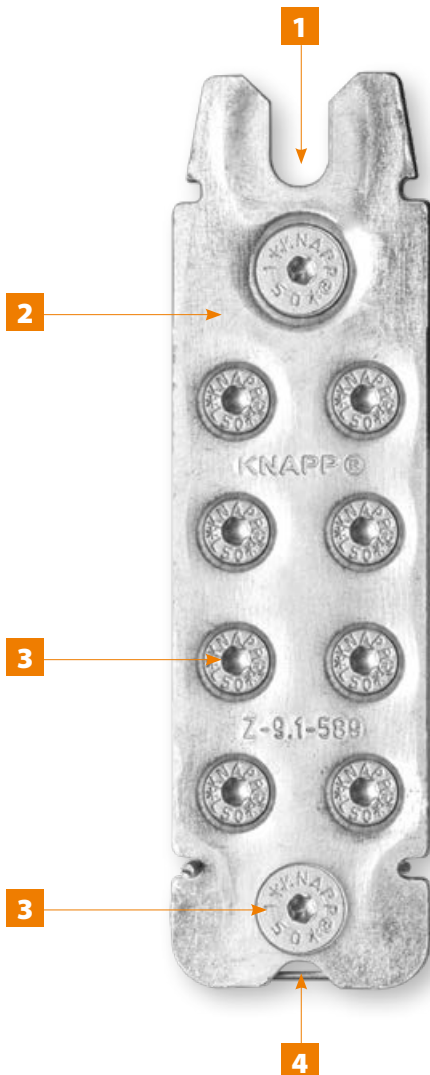

- The dovetail shape ensures optimum reception of the RICON® retaining CS-screws. The short clamping distance makes it easy to hook in, while engaging the plates, ensuring tightness and fast assembly of the elements.
- RICON® consists of two identical parts. It is made in Austria from a premium quality steel and is also available hot-dip galvanized.
- Ø 5 mm and Ø 8 mm RICON® CS-screws. These adjustable holding screws compensate fabrication tolerances. The reinforced shaft with integrated stop guarantees exact positioning.
- The stainless spring steel locking clip can be installed into the locating slots prior to final assembly. It locks the connection against the slide-indirection and can be released again.

Fire rating: Fire resistance (EN 1995-1-2) through 3-4 sided concealed, joint-tight installation (R30 ≥ 28 mm, R60 ≥ 49 mm)



RICON®

Application examples and connection details

Wood curtain wall up to 700 kg

(Dimensions in mm)

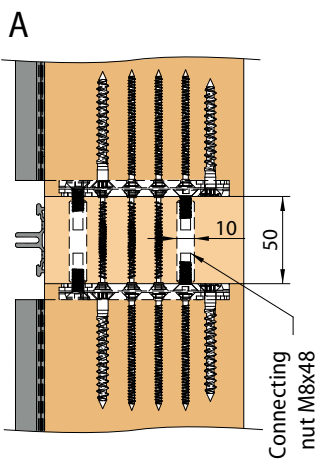
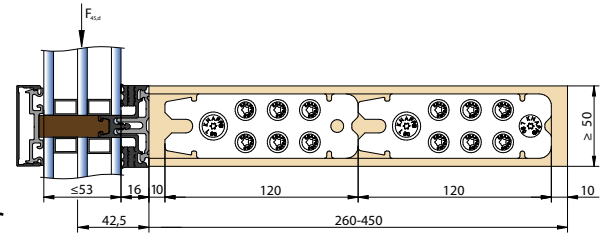
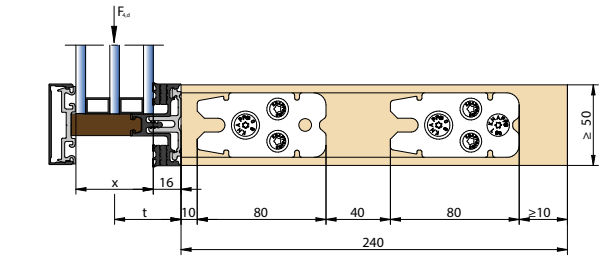
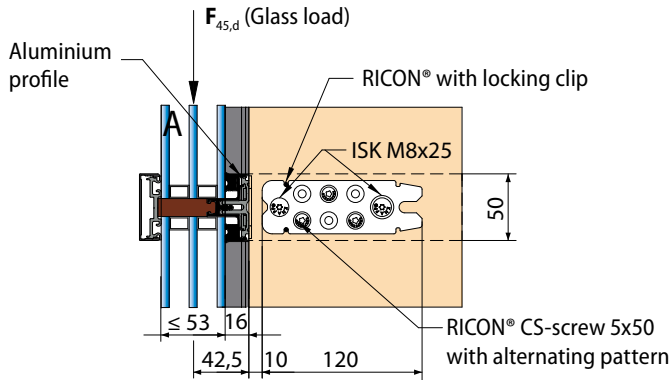

RICON® double connection

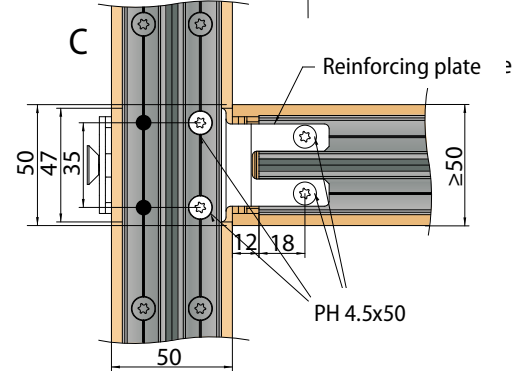
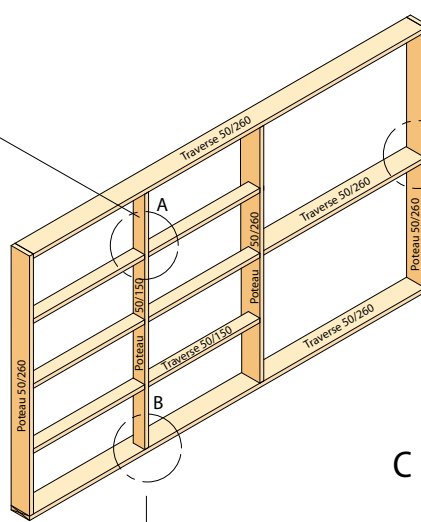

RICON® double connection with reinforcing plate (RP)

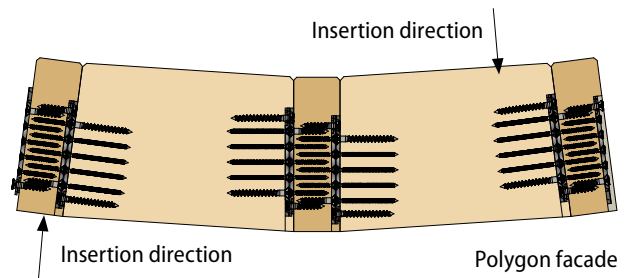
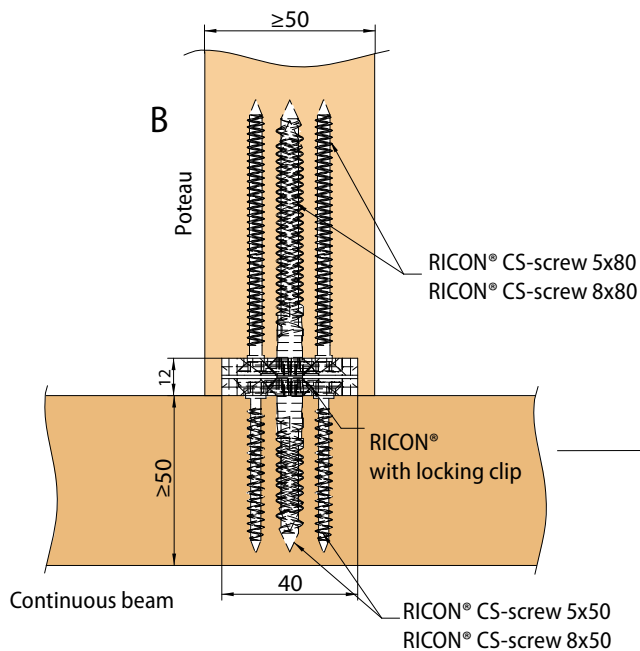

RICON®

Application examples and assembly details

Main-secondary beam connections
e.g. wood beam ceilings, roofs and sunrooms.

Wood to steel
connection

Wood to concrete connection
e.g. with RICON® 140/40

(Dimensions in mm)

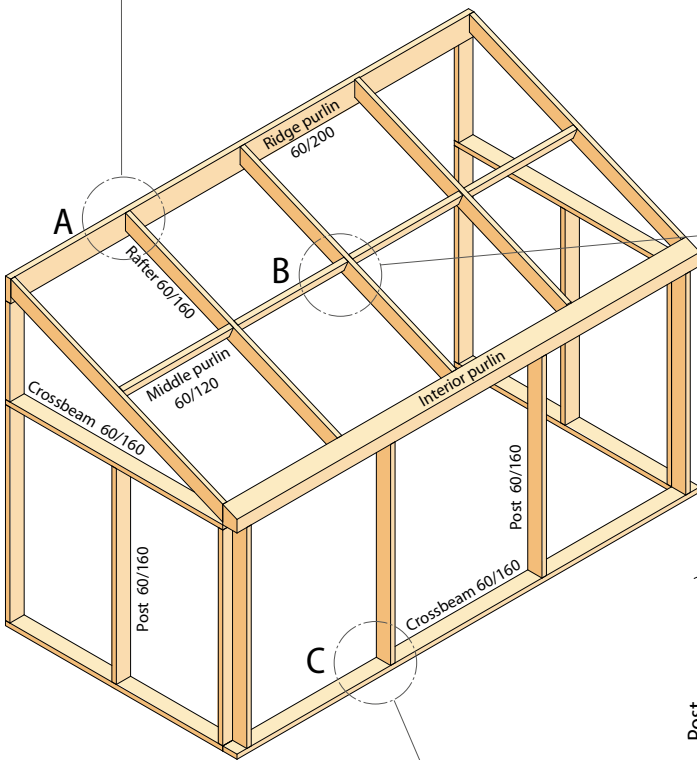
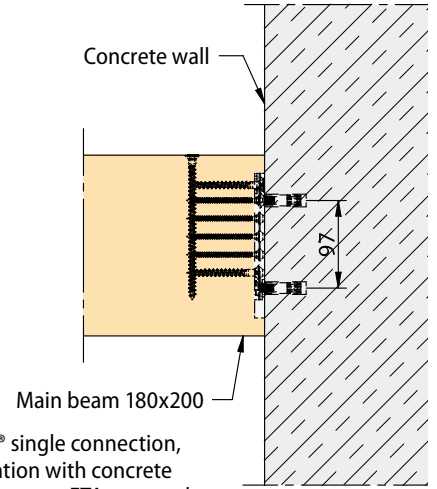
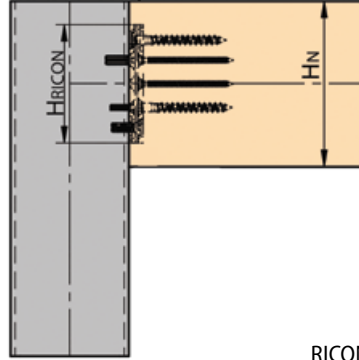
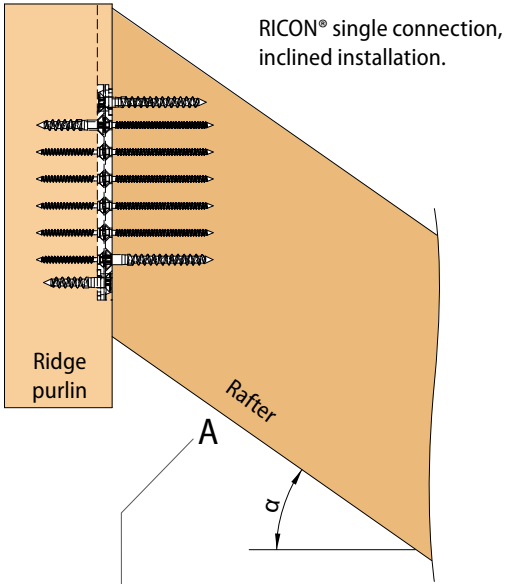

RICON®
double
connection

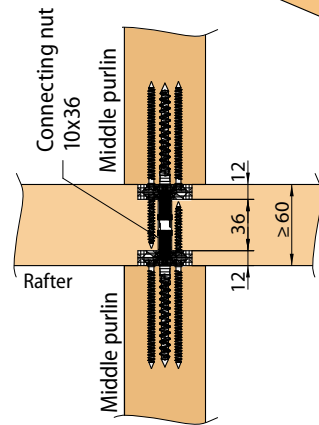
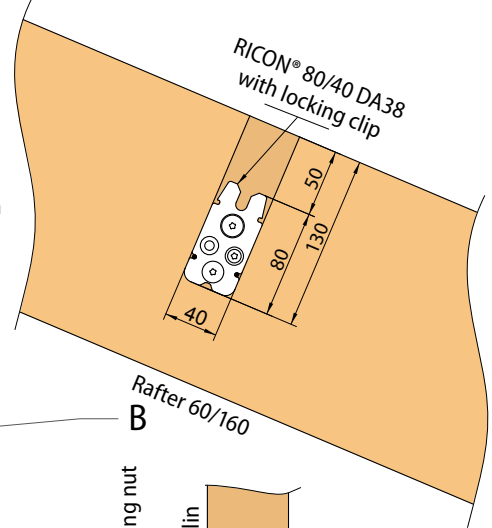

RICON®
single connection

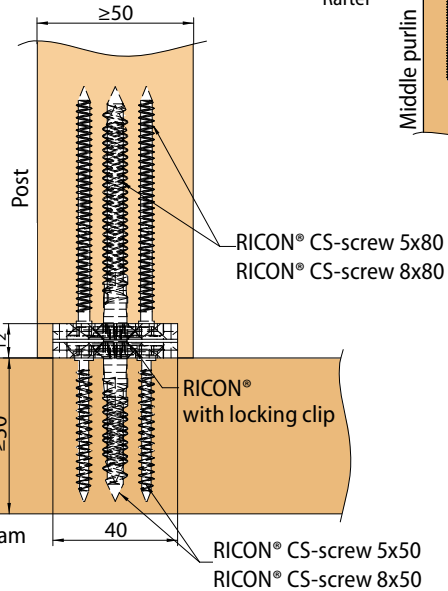

© Solarlux

Construction of a sunroom.

RICON® 60/40

(Dimensions in mm)

Minimum timber cross section

Inserted in the beam and screwed

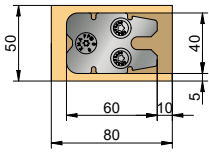

Built-in depth: 12-12.5 mm

Screwed onto post

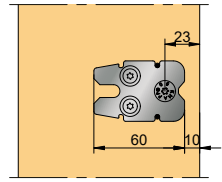

Min. width of beam and post: 50 mm

Inserted in the main beam and screwed

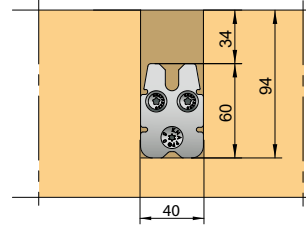

Min. width of of main beam: 60 mm

Screwed into the secondary beam

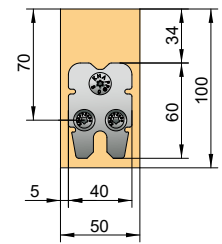

RICON® 60/40 EA - single connection

Art.-No. K360

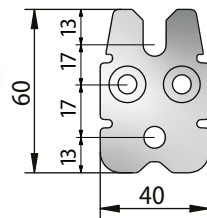

Connector	Connection	Screw connection		Charact. charge. [GL24h] C.SER.1*	
		Joist	Header	F _{1,Rk} [kN]	F _{2,Rk} [kN]
60/40	EA	2 CS 5x80 1 CS 8x80	2 CS 5x50 1 CS 8x50	4.4	5.0
1 locking clip: F _{3,Rk} = 2.7 kN			2 locking clips: F _{3,Rk} = 5.15 kN		

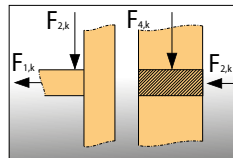

Minimum timber dimensions: 50 x 80 mm

Single connection for post and beam connection with a minimum timber cross section of 50 mm (stress at mid to the axis of beam)

* alternatively, longer screws can be used in end grain.

1 CS-screw 8x160 - F_{2,Rk} = 6.3 kN

RICON® 80/40

Minimum timber cross section

Inserted in the beam and screwed

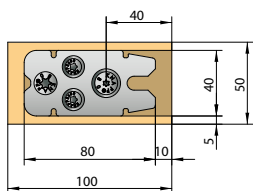

Built-in depth: 12-12.5 mm

Screwed onto post

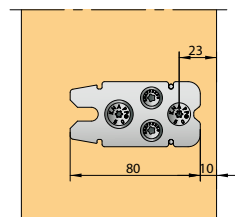

Min. width of beam and post: 50 mm

Inserted in the main beam and screwed

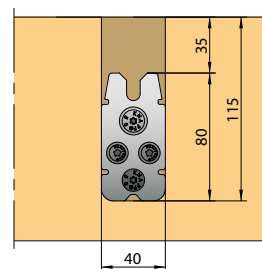

Min. width of of main beam: 60 mm

Screwed into the secondary beam

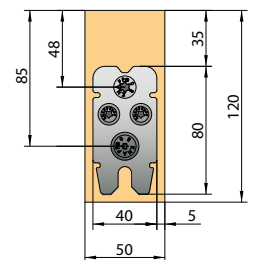

RICON® 80/40 EA - single connection

Art.-No. K361

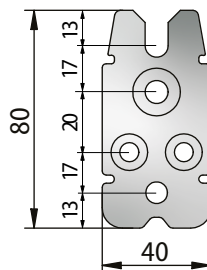

Connector	Connection	Screw connection		Charact. charge. [GL24h] C.SER.1*	
		Joist	Header	F _{1,Rk} [kN]	F _{2,Rk} [kN]
80/40	EA	2 CS 5x80 2 CS 8x80	2 CS 5x50 2 CS 8x50	4.4	7.3
1 locking clip: F _{3,Rk} = 2.7 kN			2 locking clips: F _{3,Rk} = 5.4 kN		

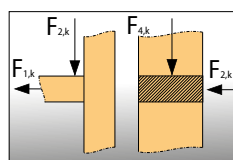

Minimum timber dimensions: 50 x 100 mm

Single connection for post and beam connection with a minimum timber cross section of 50 mm (stress at mid to the axis of beam)

* alternatively, longer screws can be used in end grain.

2 CS-screws 8x160 - F_{2,Rk} = 10.3 kN

RICON® 100/40

(Dimensions in mm)

Minimum timber cross section

Inserted in the beam and screwed

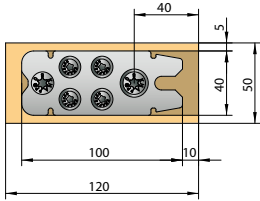

Built-in depth: 12 - 12.5 mm

Screwed onto post

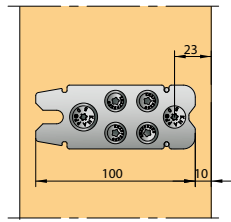

Min. width of beam and post: 50 mm

Inserted in the main beam and screwed

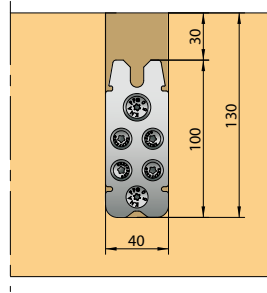

Min. width of of main beam: 60 mm

Screwed into the secondary beam

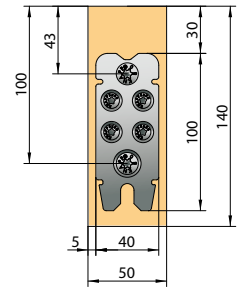

RICON® 100/40 EA - single connection

Art.-No. K362

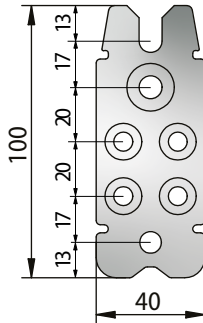

Connector	Connection	Screw connection		Charact. charge. [GL24h] C.SER.1*	
		Joist	Header	F _{1,RK} [kN]	F _{2,RK} [kN]
100/40	EA	4 CS 5x80 2 CS 8x80	4 CS 5x50 2 CS 8x50	4.4	10.0
1 locking clip: F _{3,RK} = 2.7 kN			2 locking clips: F _{3,RK} = 5.4 kN		

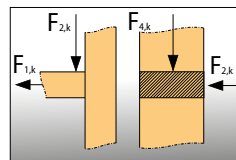

Minimum timber dimensions: 50 x 120 mm

Single connection for post and beam connection with a minimum timber cross section of 50 mm (stress at mid to the axis of beam)

* alternatively, longer screws can be used in end grain.
2 CS-screws 8x160 - F_{2,RK} = 13.9 kN

RICON® 120/40

Minimum timber cross section

Inserted in the beam and screwed

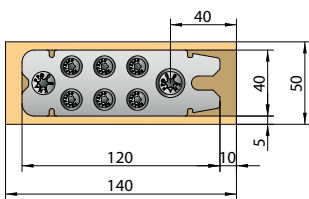

Built-in depth: 12 - 12.5 mm

Screwed onto post

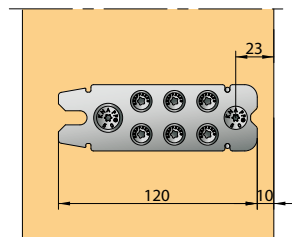

Min. width of beam and post: 50 mm

Inserted in the main beam and screwed

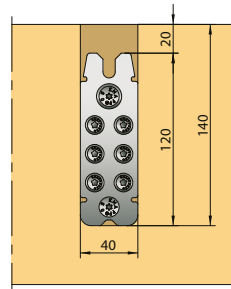

Min. width of of main beam: 60 mm

Screwed into the secondary beam

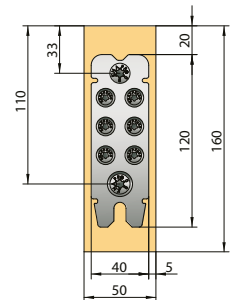

RICON® 120/40 EA - single connection

Art.-No. K363

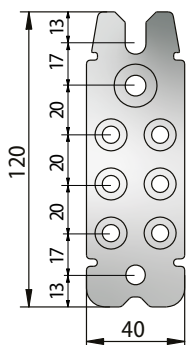

Connector	Connection	Screw connection		Charact. charge. [GL24h] C.SER.1*	
		Joist	Header	F _{1,RK} [kN]	F _{2,RK} [kN]
120/40	EA	6 CS 5x80 2 CS 8x80	6 CS 5x50 2 CS 8x50	4.4	12.8
1 locking clip: F _{3,RK} = 2.7 kN			2 locking clips: F _{3,RK} = 5.4 kN		

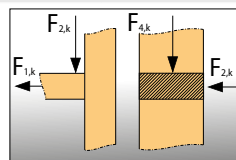

Minimum timber dimensions: 50 x 140 mm

Single connection for post and beam connection with a minimum timber cross section of 50 mm (stress at mid to the axis of beam)

* alternatively, longer screws can be used in end grain.
2 CS-screws 8x160 - F_{2,RK} = 16.6 kN

RICON® 140/40

(Dimensions in mm)

Minimum timber cross section

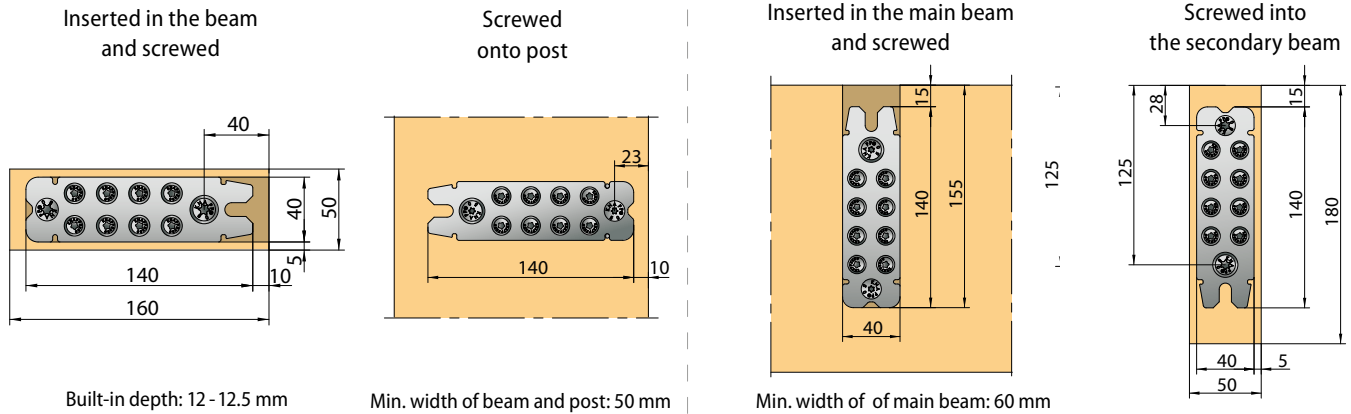

RICON® 140/40 EA - single connection

Art.-No. K365

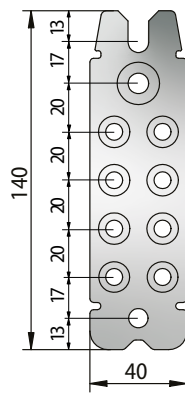

Connector	Connection	Screw connection		Charact. charge. [GL24h] C.SER.1*	
		Joist	Header	F _{1,Rk} [kN]	F _{2,Rk} [kN]
140/40	EA	8 CS 5x80 2 CS 8x80	8 CS 5x50 2 CS 8x50	4.4	15.5
			1 locking clip: F _{3,Rk} = 2,7 kN		2 locking clips: F _{3,Rk} = 5,4 kN

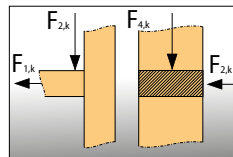

Minimum timber dimensions: 50 x 160 mm

Single connection for post and beam connection with a minimum timber cross section of 50 mm (stress at mid to the axis of beam)

* alternatively, longer screws can be used in end grain.
2 CS-screws 8x160 - F_{2,Rk} = 19,3 kN

RICON® 160/40

Minimum timber cross section

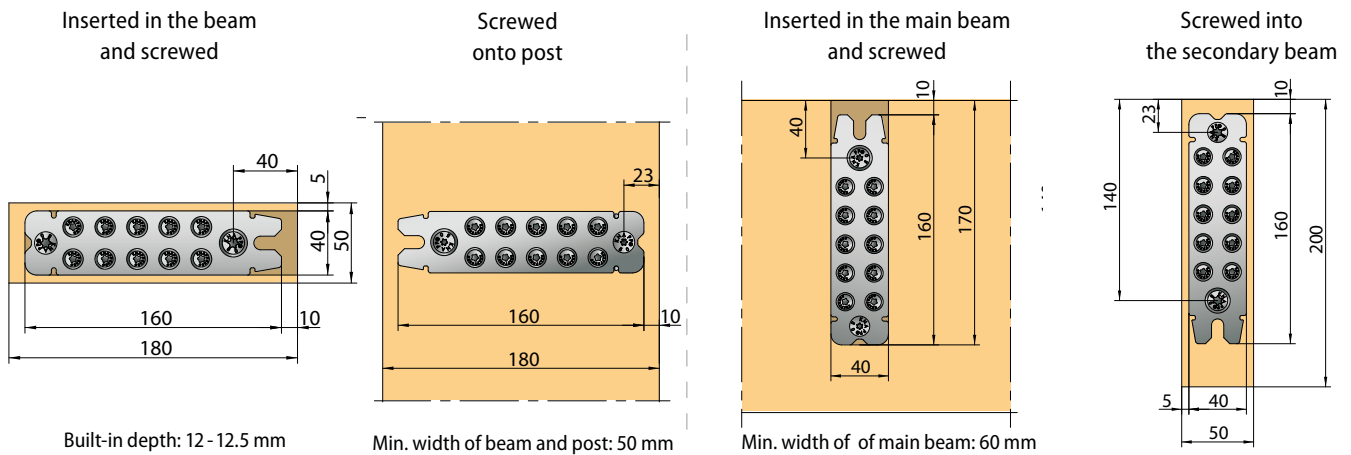

RICON® 160/40 EA - single connection

Art.-No. K364

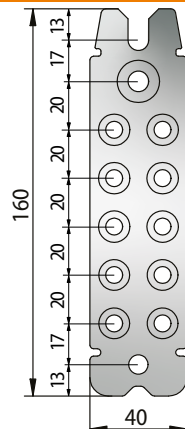

Connector	Connection	Screw connection		Charact. charge. [GL24h] C.SER.1*	
		Joist	Header	F _{1,Rk} [kN]	F _{2,Rk} [kN]
160/40	EA	10 CS 5x80 2 CS 8x80	10 CS 5x50 2 CS 8x50	4.4	18.2
			1 locking clip: F _{3,Rk} = 2,7 kN		2 locking clips: F _{3,Rk} = 5,4 kN

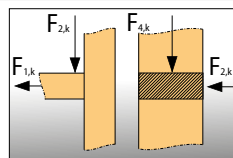

Minimum timber dimensions: 50 x 180 mm

Single connection for post and beam connection with a minimum timber cross section of 50 mm (stress at mid to the axis of beam)

* alternatively, longer screws can be used in end grain.
2 CS-screws 8x160 - F_{2,Rk} = 22.0 kN

RICON®

Load bearing capacities for timber curtain wall example

(Dimensions in mm)

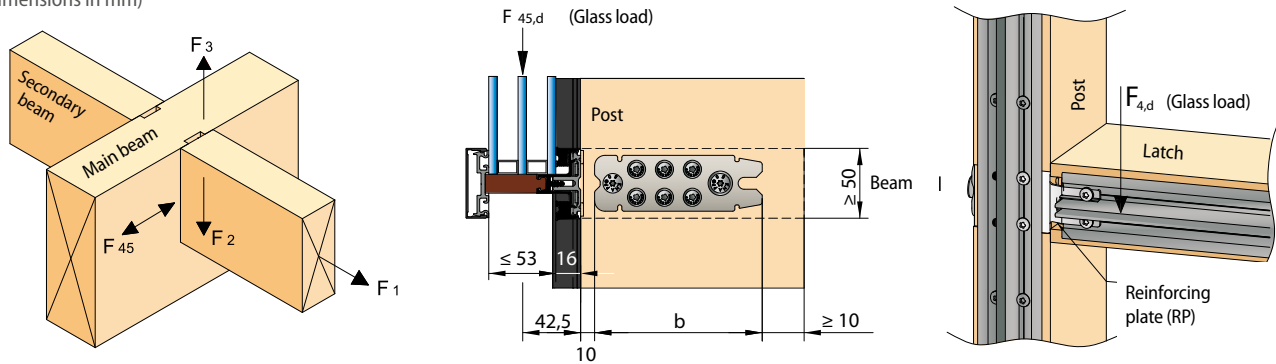

RICON®	Timber grade	Characteristic values			Charact. charge. [kN] $F_{3,Rk}$		Eccentric glass loads/post $F_{4,Rd}$	
		$F_{1,Rk}$ [kN]	$F_{2,Rk}$ [kN]	Centred $F_{45,Rk}$ [kN]	Locking clip(s)		without VP [kg]	with VP [kg]
					1	2		
60/40	C24	4,1	4,7	5,2	2,7	5,0	43	317
	GL24h	4,4	5,0	5,2			47	320
	GL32h	4,9	5,5	5,2			52	326
80/40	C24	4,1	6,8	8,0	2,7	5,4	59	332
	GL24h	4,4	7,3	8,7			64	337
	GL32h	4,9	8,1	9,7			71	345
100/40	C24	4,1	9,4	11,8	2,7	5,4	94	368
	GL24h	4,4	10,0	12,8			102	376
	GL32h	4,9	11,0	14,3			114	388
120/40	C24	4,1	12,0	15,4	2,7	5,4	131	404
	GL24h	4,4	12,8	15,6			142	415
	GL32h	4,9	14,0	15,6			158	432
140/40	C24	4,1	14,5	15,6	2,7	5,4	169	443
	GL24h	4,4	15,5	15,6			183	457
	GL32h	4,9	16,9	15,6			205	478
160/40	C24	4,1	17,1	15,6	2,7	5,4	210	484
	GL24h	4,4	18,2	15,6			227	501
	GL32h	4,9	19,9	15,6			254	528
2 x 80/40	C24	4,1	11,5	10,4	2,7	5,4	180	453
	GL24h	4,4	12,3	10,4			195	468
	GL32h	4,9	13,6	10,4			218	491
2 x 100/40	C24	4,1	16,6	15,6	2,7	5,4	270	543
	GL24h	4,4	17,8	15,6			292	566
	GL32h	4,9	19,5	15,6			327	600
2 x 120/40	C24	4,1	21,8	15,6	2,7	5,4	356	630
	GL24h	4,4	23,2	15,6			385	659
	GL32h	4,9	25,4	15,6			431	704

Tested at the University of Karlsruhe (KIT), **Building certification:** ETA-10/0189

Monitored by Univ.-Prof. Dr.-Ing. Blaß. at the University of Karlsruhe (KIT) Research Center for Steel, Timber and Masonry.

$F_{1,Rk}/F_{1,Rd}$ Characteristic/Design values of load-bearing capacity in the case of single stress perpendicular to the connector plate (tension)

$F_{2,Rk}/F_{2,Rd}$ Characteristic/Design values in slide-in direction

$F_{3,Rk}/F_{3,Rd}$ Characteristic/Design values against the slide-in direction

$F_{45,Rk}/F_{45,Rd}$ Characteristic/Design values perpendicular to slide-in direction

Glazing up to 1100 kg with the Schüco AOC.TI curtain wall profile system:

In combination with RICON® connectors for the assembly of the wooden supporting structure and with the help of suitable glazing supports, this system allows glazing loads of up to 1,100 kg per crossbar.
www.schueco.com

RICON® reinforcing plate (inox)**

K519	K523	K530	K531	K533	K534	K535	K536	K537	K538	K539
Schüco GP 50/50 50 mm*	Schüco GP 50/60 60 mm*	RP RP-tecline 50A0-HA 50mm*	RP RP-tecline 60A0-HA 60mm*	RP RP-tecline 80A0-HA 80mm*	Gutmann P GF 50 50 mm*	Gutmann P GF 60 60 mm*	Gutmann P GF 80 80 mm*	RAICO GP 41 and 47 50 mm*	RAICO GP 41 and 47 60 mm*	RAICO GP 67 80 mm*

Application: The reinforcing plate connects the base aluminium profiles and increases the load capacity of the post and beam connection. The reinforcing plate is available for different base profiles (see table). Reinforcing plates for other profiles on request.

*width of post and beam



** Reinforcing plates are approved by the building authorities for all common systems as shown in ETA-10/0189.

RICON® DA and EAR for all sizes

Double connection with connecting nuts and RICON® CS-screws

DA

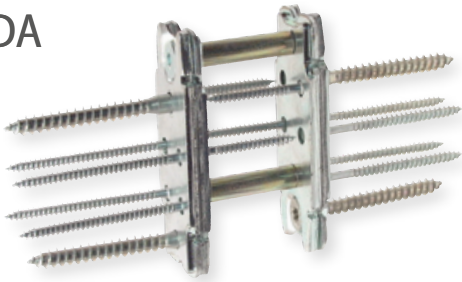

RICON DA

Single- or dual connection with insert and RICON® CS-screws

EAR



RICON EAR

RICON® screws

RICON® Self-tapping CS-screws with reinforced shaft
(CS-screws are included with all RICON® connectors)

Art.-No. Z533	CS-screws 5x50
Art.-No. Z531	CS-screws 8x50



Application: to mount RICON plate into the side grain of main beam/post.

Art.-No. Z534	CS-screws 5x80
Art.-No. Z532	CS-screws 8x80
Art.-No. Z581	CS-screws 8x160



Application: to mount RICON plate into the end grain of secondary beam.

CS-screws (CS) RICON® DA

Art.-No. Z545	CS-screws RICON® M5x20 (for RICON® 60/40 DA)
Art.-No. Z548	CS-screws RICON® M8x25



Application: to mount RICON plate in a cross joint double connector application.

Connecting nuts RICON® DA

(Connecting nuts are included with all RICON DA connectors)

Art.-No. K540	Connecting nut M5 8x48	50 mm post thickness
Art.-No. K541	Connecting nut M5 8x53	55 mm post thickness
Art.-No. K542	Connecting nut M5 8x58	60 mm post thickness
Art.-No. K543	Connecting nut M5 8x78	80 mm post thickness



Application: to mount RICON® 60/40 double connector (DA).

Art.-No. K544	Connecting nut M8 10x36	<50 mm post thickness
Art.-No. K545	Connecting nut M8 10x48	50 mm post thickness
Art.-No. K546	Connecting nut M8 10x53	55 mm post thickness
Art.-No. K547	Connecting nut M8 10x58	60 mm post thickness
Art.-No. K548	Connecting nut M8 10x68	70 mm post thickness
Art.-No. K549	Connecting nut M8 10x78	80 mm post thickness



Application: to mount RICON 80/40 and bigger sizes double connectors.

Inserts RICON® EAR

(connecting inserts can be included upon request)

Art.-No. Z540	Insert M5x14 for RICON® 60/40
Art.-No. Z541	Insert M8x18



Application: for unique applications and post sizes.

RICON® accessories

Routing-jig for all RICON® sizes

Art.-No. K502 Routing-jig MULTI F40 (plywood)

Note: the routing-jig MULTI F is suitable for a \varnothing 30 mm bushing guide (for plunge router) and a \varnothing 15 mm TCT router cutter.

Application: for milling the pocket to recess connector for concealed mounting.



RICON® EA/DA drilling-jig guide (galvanized steel)

Art.-No.	K621	K622	K623	K624	K629	K630
	60/40	80/40	100/40	120/40	140/40	160/40

Application: for installation into the drilling-jig and exact pre-drilling of the positioning screws.



TCT slotting cutter

Art.-No. Z066 2 flute straight router bits \varnothing 15 mm, 25 mm length with \varnothing 8 mm shank

Application: to recess the rebate for RICON® and GIGANT.



RICON® locking clip (stainless spring steel)

Art.-No. K064 RICON® locking clip

Application: to lock the connectors against slide-in direction. If necessary, the connection can be released again.



RICON® EA/DA drilling-jig for post-beam connections

Art.-No.	K634	K635	K636	K637	K638	K639
	60/40 Set	80/40	100/40	120/40	140/40	160/40

RICON® EA/DA drilling-jig for header-joint connections

Art.-No.	K634	K642	K643	K644	K645	K646
	60/40 Set	80/40	100/40	120/40	140/40	160/40

Application: guide for pre-drilling holes of all RICON® connectors.



RICON® drilling-jig with adjustable drilling blocks

Art.-No.	-	K647	K647	K647	K647	K647
Drilling blocks:	-	80/40	100/40	120/40	140/40	160/40

Application: guide for pre-drilling holes of all RICON® connectors.

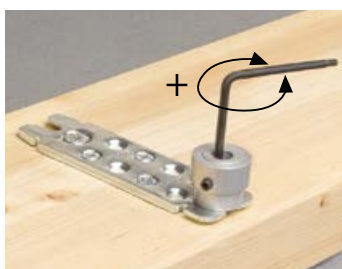

RICON® mounting set

Art.-No. K065 Consisting of: 1 RICON®-depth gauge incl. 1 Torx wrench T25 combined with Allen key SW5

Application: for fine tuning of RICON® CS-screws.



RICON® and RICON® inox

Post-beam connection for curtain walls (EA and DA)

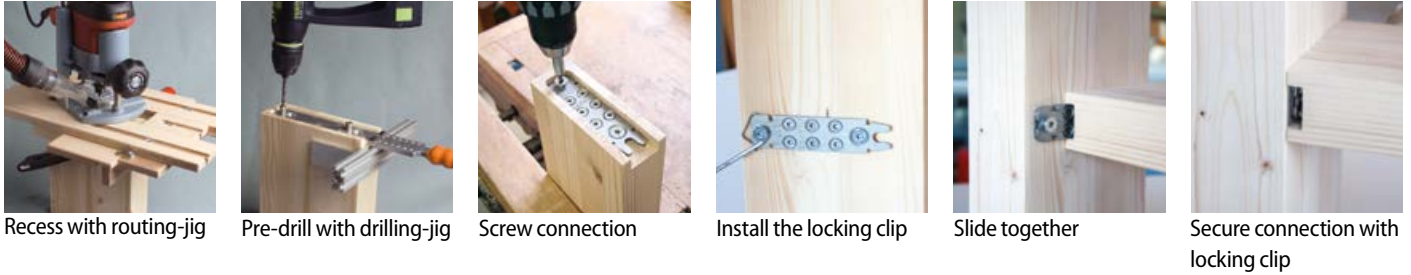

Locking clip

Depending on load requirements, the locking clip can be inserted on one or on both sides. If the connection is accessible, it can be unlocked.



To unlock the connection, it is necessary to bend up the locking clip in its center e.g. with a screwdriver.

Routing dimension RICON® inox

Width	Height	Depth
40.5 mm	variable	11.5 ^{+0,5} mm
30.5 mm	variable	11.5 ^{+0,5} mm
20.0 mm	80 mm	11.0 ^{+0,5} mm
16.0 mm	66 mm	11.0 ^{+0,5} mm

Routing dimension RICON®

Width	Height	Depth
40 mm	variable	12 mm

The recess can be routed on either side depending on the application. In this case (left picture), the connector plate is recessed into the beam/latch.

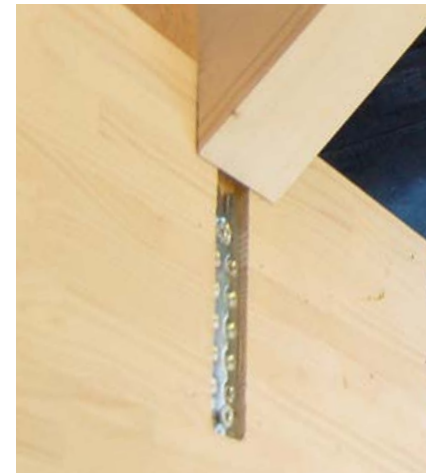

Rafter connection with RICON® 160/40.

RICON® wood to steel connection

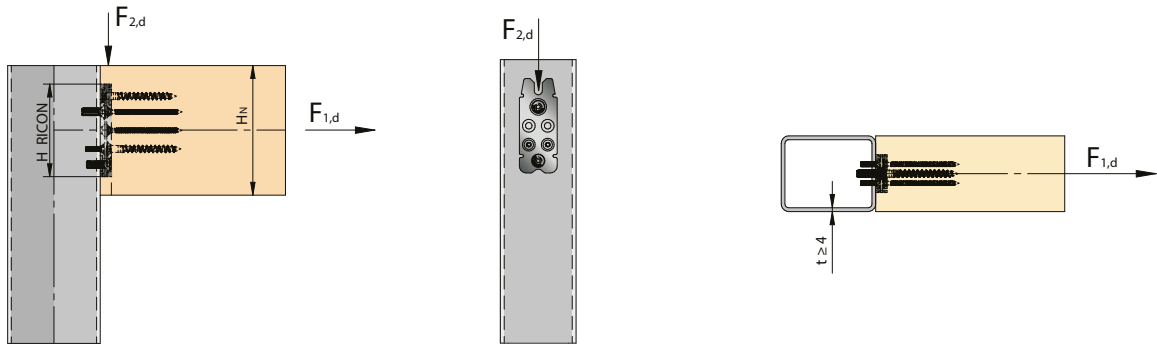

KNAPP® connector	Traction		Shear force	
	$F_{t,Rk}$ [kN]* on 4 mm steel	$F_{1,Rk}$ [kN]* on glulam GL24h	$F_{v,Rk}$ [kN]* on 4 mm steel	$F_{2,Rk}$ [kN]* on glulam GL24h
RICON 60x40	30,8	4,4	31,6	5,0
RICON 80x40				7,3
RICON 100x40				10,0
RICON 120x40				12,8
RICON 140x40				15,5
RICON 160x40				18,2
Sizing value calculation	$F_{t,Rd} = F_{t,Rk} / \gamma_{M,2}$	$F_{1,Rd} = k_{mod} \times F_{1,Rk} / \gamma_M$	$F_{v,Rd} = F_{v,Rk} / \gamma_{M,2}$	$F_{1,Rd} = k_{mod} \times F_{1,Rk} / \gamma_M$
	$\gamma_{M,2} = 1,25$	$\gamma_M = 1,3$	$\gamma_{M,2} = 1,25$	$\gamma_M = 1,3$
		$k_{mod} = 0,8$ KLED medium		$k_{mod} = 0,8$ KLED medium
		$k_{mod} = 0,9$ KLED short		$k_{mod} = 0,9$ KLED short
*Screw connection	2 CS M8x25 2 CS M5x20	RICON® end-grain screw connection CS 8x80, CS 5x80	2 CS M8x25 2 CS M5x20	RICON® end-grain screw connection CS 8x80, CS 5x80

RICON® wood to concrete connection

Header-joist connection with glued anchor

(Dimensions in mm)

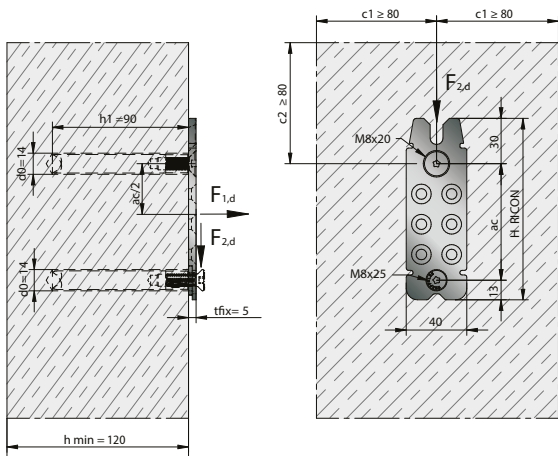

Concrete strength class C20/25

fischer RG 12x90 M18 I (8.8) with CS M8x25 and CS M8x20 (zinc-coated steel)

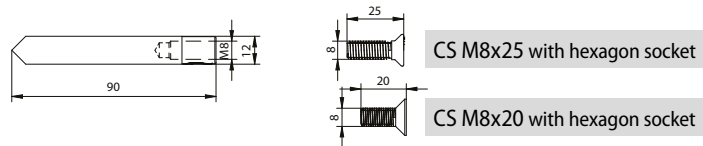

CS M8x25 with hexagon socket

CS M8x20 with hexagon socket

fischer Superbond-System: FIS SB 390 S

Drill hole diameter d_0	= 14 mm
Drill hole depth h_1	= 90 mm
Total fixing thickness C_{fix}	= 5 mm
Spacing a_c	= cf. table
Minimal edge distance $c_{1,\text{min}} = c_{2,\text{min}}$	= 80 mm
Minimal concrete wall thickness h_{min}	= 120 mm
Approval:	ETA-12/0258



Wood to concrete connection in slide-in direction F_2

F_2 load-bearing values in the direction of insertion

KNAPP® connector	Concrete connection		Timber connection						
	$F_{2,\text{Rd,concrete}}$	Spacing	Wood material		$F_{2,\text{Rd,timber}}$				
	Shear force $F_{2,\text{Rd,concrete}}$ [kN]	Dowel spacing a_c [mm]	Wood type	Char. Density ρ_k [kg/m³]	Characteristic values [kN]		Design values $F_{2,\text{Rd}, Y_M = 1,3}$ [kN]		
					$F_{2,\text{KCC,Rk}}, Y_M = 1,0$	$F_{2,\text{Rk}}$	$k_{\text{mod}} = 0,6$	$k_{\text{mod}} = 0,8$	$k_{\text{mod}} = 0,9$
RICON® 100/40	14,00	57,00	C24	350	14,00	9,40	4,34	5,78	6,51
			GL24h	385					
RICON® 120/40	18,00	77,00	C24	350	14,00	12,00	5,54	7,38	8,31
			GL24h	385					
RICON® 140/40	18,00	97,00	C24	350	18,00	14,50	6,69	8,92	10,04
			GL24h	385					
RICON® 160/40	18,00	117,00	C24	350	18,00	17,10	7,89	10,52	11,84
			GL24h	385					

Service class: 1-2

$Y_{M,\text{timber}} = 1,3$

Calculation of $F_{2,\text{Rd}}$ for timber-concrete connection:

$$F_{2,\text{Rk}} = \min \left\{ \begin{array}{l} \min F_{2,\text{Rd,timber}} \\ \min F_{2,\text{Rd,concrete}} \end{array} \right. \quad F_{2,\text{Rk,timber}} = \min \left\{ \begin{array}{l} \min F_{2,\text{KCC,Rk}} / Y_M \\ \min F_{2,\text{Rk}} \cdot k_{\text{mod}} \end{array} \right. / Y_{M,\text{timber}}$$

Note:

The fischer anchors for KNAPP wood-to-concrete connections were determined according to the above tables and on the basis of a concrete class C20/25 with the fischer C-FIX calculation tool. They have been specially checked by fischer. Any cases outside the tables must be checked by KNAPP®, fischer or a competent engineer. In many cases, dimensioning with the C-FIX calculation tool is sufficient. The complete analysis of concrete fasteners is available on request from KNAPP®. KNAPP® accepts no liability for the incorrect use of the tables in this document. The condition of the concrete elements (strength classes and surfaces) must be checked by a professional, KNAPP® accepts no responsibility for this. KNAPP® products and KNAPP® connectors must be installed in accordance with the respective installation rules and instructions as well as the respective Technical Assessments.

Other anchoring solutions are possible, they must be technically suitable and have an ETA technical assessment.

Header-joist connection with heavy duty anchor

fischer FH II 12/M8 I (8.8) with CS M8x30 (zinc-coated steel)

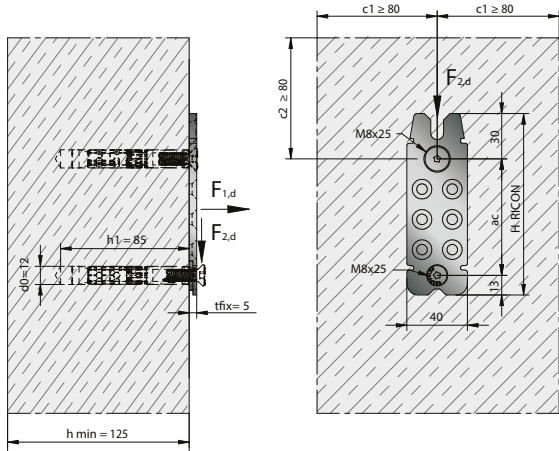

Concrete strength class C20/25

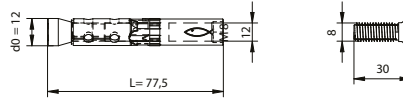

CS M8x30 with hexagon socket

Drill hole diameter $d_0 =$	12 mm
Drill hole depth $h_1 =$	85 mm
Total fixing thickness $C_{fix} =$	5 mm
Spacing $a_c =$	cf. table
Minimal edge distance $c_{1,min} = c_{2,min} =$	80 mm
Minimal concrete wall thickness $h_{min} =$	125 mm
Approval:	ETA-07/0025, Option 1

Wood to concrete connection in slide-in direction F_2

F_2 load-bearing values in the direction of insertion

KNAPP® connector	Concrete connection		Timber connection						
	$F_{2,Rd,concrete}$	Spacing	Wood material		$F_{2,Rd,timber}$				
	Shear force $F_{2,Rd,concrete}$ [kN]	Dowel spacing a_c [mm]	Wood type	Char. Density, ρ_k [kg/m³]	Design values $F_{2,Rd, \gamma_M = 1,3}$ [kN]				
					$F_{2,KCC,Rk} \cdot \gamma_M = 1,0$	$F_{2,Rk}$	$k_{mod} = 0,6$	$k_{mod} = 0,8$	$k_{mod} = 0,9$
RICON® 100/40	14,00	57,00	C24	350	14,00	9,40	4,34	5,78	6,51
			GL24h	385					
RICON® 120/40	16,00	77,00	C24	350	14,00	12,00	5,54	7,38	8,31
			GL24h	385					
RICON® 140/40	18,00	97,00	C24	350	18,00	14,50	6,69	8,92	10,04
			GL24h	385					
RICON® 160/40	18,00	117,00	C24	350	18,00	17,10	7,89	10,52	11,84
			GL24h	385					

Service class : 1-2
 $\gamma_{M,bois} = 1,3$

Calculation of $F_{2,Rd}$ for timber-concrete connection:

$$F_{2,Rk} = \min \left\{ \begin{array}{l} \min F_{2,Rd, timber} \\ \min F_{2,Rd, concrete} \end{array} \right. \quad F_{2,Rd, timber} = \min \left\{ \begin{array}{l} \min F_{2,KCC, Rk} / \gamma_M \\ \min F_{2,Rk} \cdot k_{mod} \end{array} \right. / \gamma_{M, timber}$$

Note:
 The fischer anchors for KNAPP wood-to-concrete connections were determined according to the above tables and on the basis of a concrete class C20/25 with the fischer C-FIX calculation tool. They have been specially checked by fischer. Any cases outside the tables must be checked by KNAPP®, fischer or a competent engineer. In many cases, dimensioning with the C-FIX calculation tool is sufficient. The complete analysis of concrete fasteners is available on request from KNAPP®. KNAPP® accepts no liability for the incorrect use of the tables in this document. The condition of the concrete elements (strength classes and surfaces) must be checked by a professional, KNAPP® accepts no responsibility for this. KNAPP® products and KNAPP® connectors must be installed in accordance with the respective installation rules and instructions as well as the respective Technical Assessments.

Other anchoring solutions are possible, they must be technically suitable and have an ETA technical assessment.

Connection types and fire rating

Connection options

- The Beam Hanger System can be installed with various housing options to provide an architecturally appealing and fully concealed connection in mass timber elements.
- This concealed arrangement also helps provide fire protection, as explained in the following sections.

Typical concealed configuration achieved through routing for fire-rated connections

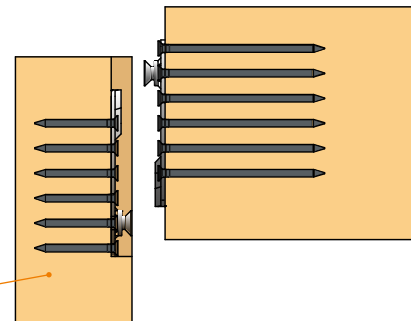

Application examples and connection details

Top view of 3 concealed installation options

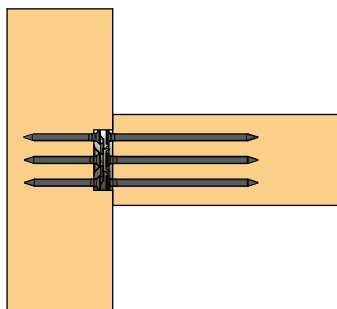

Connector housed in main beam

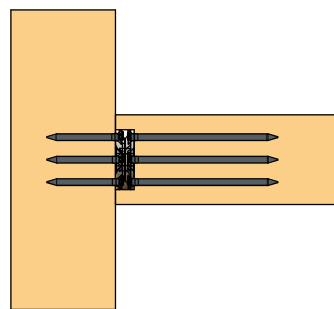

Connector housed in secondary beam

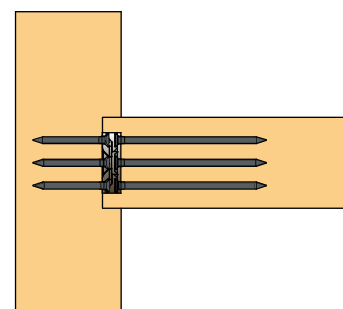

Connector housed in secondary beam

Fire protection

- Due to the concealed installation of the connectors on three or four sides, the wooden cover can provide the appropriate fire protection.
- Due to the joint-tight connection, no additional coverings or fire or fire protection tapes are required. According to EN 1995-1-2 point 3.4.3.1 the joint must not exceed 2 mm.
- If, due to manufacturing tolerances or for installation reasons, larger joints are required (2 - 10 mm), PROMASEAL®-PL* intumescent sealant can be used as protection. The flexible joint tape is placed around the connector, expands and fills the joint in the event of fire in the event of fire, thus protecting the connector.
- According to Eurocode EN 1995-1-2 5, 30 minutes of fire resistance requires a wood covering of 60 minutes - 49 mm, 90 minutes - 70 mm, 120 minutes - 91 mm (see calculations on page 35).
- In special situations (e.g. where the wood overlap is not respected), combustion can be reduced by using Promat PROMADUR®** transparent fireproof paint. In the event of fire, the material expands and forms a protective insulating foam that delays combustion by 6 to 17 min (depending on the thickness of the paint) and allows smaller sections of wood to be used.



RICON®S connector after 120 minutes and MEGANT® connector after 60 minutes fire tests. The wood is charred all around. The connectors withstood the the vertical load applied in the fire test.

© Softwood Lumber Board, Atrop, MTC, DR Johnson

* For more information on the use and specification of fire protection materials, please contact our Planer Service department.

Connectors

Fire resistance / Fire protection

RICON®

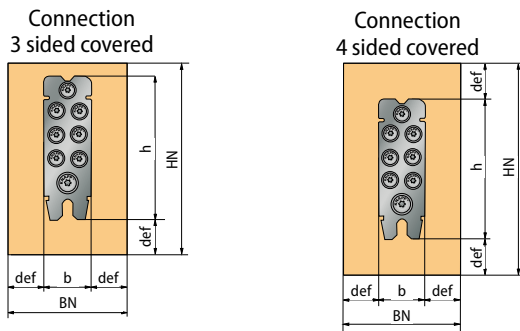

RICON®S

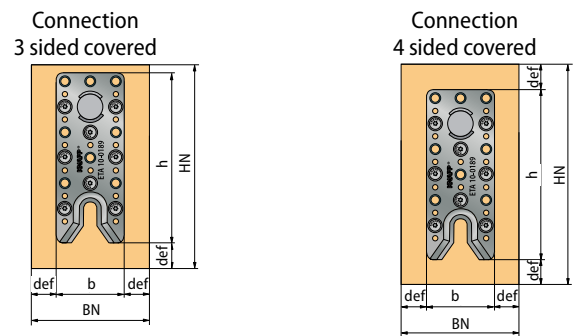

- Fully concealed connections (3 - 4 sides) possible where required by architect or fire code consultant.
- Jointless connection (joint < 2 mm according to EN 1995-1-2 chap. 3.4.3.1) => no additional covers or fire protection tapes required.
- According to EN 1995-1-2 ch. 4, 28 mm of timber covering is required for 30 minutes of fire resistance. Higher coverages are also possible through larger timber cross-sections for R60, R90 and R120.

Calculation of the protecting wood covering for the fire resistance of the KNAPP® connectors according to EN 1995-1-2 ch. 4:

Common formula: $d_{ef} = \beta_n \cdot t + k_0 \cdot d_0$

Mass burning rate β_n :

Softwood and beach glulam with charact. density $\rho_k \geq 290 \text{ kg/m}^3$	$\beta_n = 0,7 \text{ mm/min}$
Softwood and beach solid wood with charact. density $\rho_k \geq 290 \text{ kg/m}^3$	$\beta_n = 0,8 \text{ mm/min}$
Hardwood and Hardwood glulam with charact. density $\rho_k \geq 290 \text{ kg/m}^3$	$\beta_n = 0,7 \text{ mm/min}$
Hardwood and Hardwood glulam with charact. density $\rho_k \geq 450 \text{ kg/m}^3$	$\beta_n = 0,55 \text{ mm/min}$
LVL with charact. density $\rho_k \geq 480 \text{ kg/m}^3$	$\beta_n = 0,7 \text{ mm/min}$
Duration of fire exposure	$t = 30, 60, 90, 120 \text{ min}$
Temperature-dependent reduction factor for strength and stiffness properties	$k_0 = 1 (t \geq 20 \text{ min})$
Time factor	$k_0 = t / 20 (t < 20 \text{ min})$
Layer depth with the strength and stiffness properties equal to zero	$d_0 = 7 \text{ mm}$

Softwood Gluelam, Beach solid wood and laminated wood

Wood overlap for 30 minutes fire resistance	$d_{ef} = 0,7 \times 30 + 1,0 \times 7 =$	28 mm for R30
Wood overlap for 60 minutes fire resistance	$d_{ef} = 0,7 \times 60 + 1,0 \times 7 =$	49 mm for R60
Wood overlap for 90 minutes fire resistance	$d_{ef} = 0,7 \times 90 + 1,0 \times 7 =$	70 mm for R90
Wood overlap for 120 minutes fire resistance	$d_{ef} = 0,7 \times 120 + 1,0 \times 7 =$	91 mm for R120

Solid Hardwood and Hardwood Gluelam (e.g. oak):

Wood overlap for 30 minutes fire resistance	$d_{ef} = 0,55 \times 30 + 1,0 \times 7 =$	23,5 mm for R30
Wood overlap for 60 minutes fire resistance	$d_{ef} = 0,55 \times 60 + 1,0 \times 7 =$	40 mm for R60
Wood overlap for 90 minutes fire resistance	$d_{ef} = 0,55 \times 90 + 1,0 \times 7 =$	56,5 mm for R90
Wood overlap for 120 minutes fire resistance	$d_{ef} = 0,55 \times 120 + 1,0 \times 7 =$	73 mm for R120

Connectors installation options

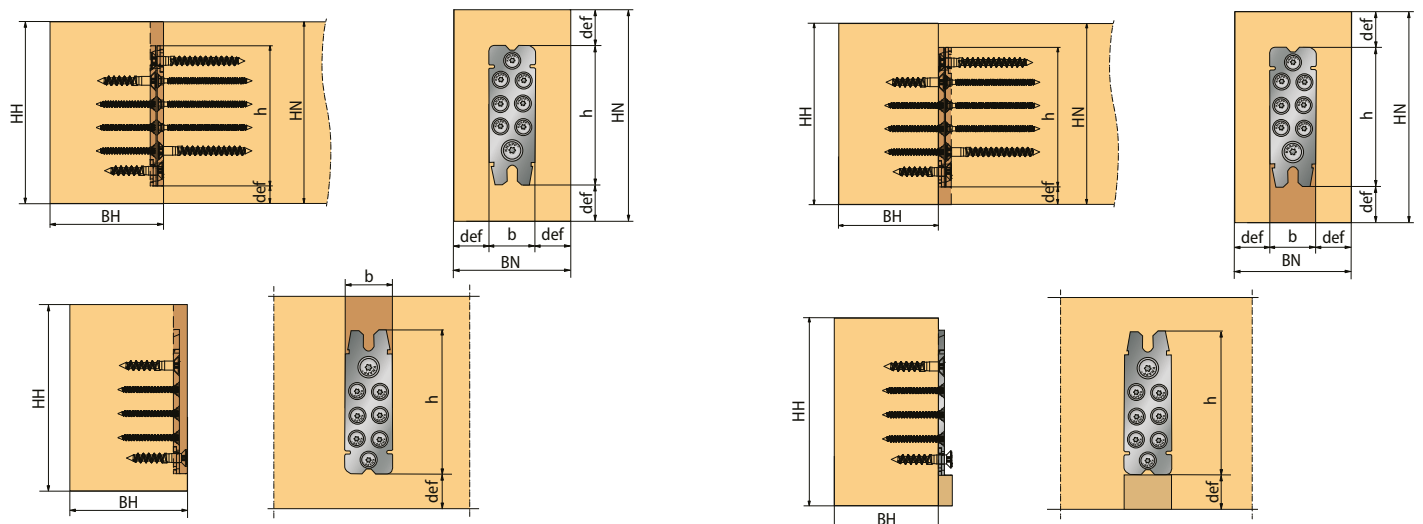

3 sided fire protection, milling in main beam

3 sided fire protection, milling in secondary beam

RICON® EA Startbox

RICON® Boxes - for post-beam and main-secondary beam connections up to 23.4 kN

Art.-No. K364/B



RICON®



TCT slotting
cutter 15x25 mm



Routing-jig
MULTI F



Drilling-jig



Depth gauge



Locking clip

Each RICON® Box includes:

6, 12 or 24 pairs RICON®,
1 HM routing cutter,
1 routing-jig MULTI F 40/R,
1 drilling-jig,
1 depth gauge, CS-screws and
the locking clips

Applications : Curtain wall,
Winter garden, carport, etc.

RICON® EA Box | Art.-No. K364/B
6 pairs of 60/40 EA, 80/40 EA, 100/40 EA
and 120/40 EA, 24 locking clips and
RICON® CS-screws



RICON® EA 60 Box

Art.-No. K366
24 pairs of RICON® 60/40
48 CS-screws RICON® 5x50 mm
48 CS-screws RICON® 5x80 mm
24 CS-screws RICON® 8x50 mm
24 CS-screws RICON® 8x80 mm
24 locking clips



RICON® EA 80 Box

Art.-No. K367
24 pairs of RICON® 80/40
48 CS-screws RICON® 5x50 mm
48 CS-screws RICON® 5x80 mm
48 CS-screws RICON® 8x50 mm
48 CS-screws RICON® 8x80 mm
24 locking clips



RICON® EA 100 Box

Art.-No. K368
24 pairs of RICON® 100/40
96 CS-screws RICON® 5x50 mm
96 CS-screws RICON® 5x80 mm
48 CS-screws RICON® 8x50 mm
48 CS-screws RICON® 8x80 mm
24 locking clips



RICON® EA 120 Box

Art.-No. K369
12 pairs of RICON® 120/40
72 CS-screws RICON® 5x50 mm
72 CS-screws RICON® 5x80 mm
24 CS-screws RICON® 8x50 mm
24 CS-screws RICON® 8x80 mm
12 locking clips



RICON® EA 140 Box

Art.-No. K370
12 pairs of RICON® 140/40
96 CS-screws RICON® 5x50 mm
96 CS-screws RICON® 5x80 mm
24 CS-screws RICON® 8x50 mm
24 CS-screws RICON® 8x80 mm
12 locking clips



RICON® EA 160 Box

Art.-No. K371
12 pairs of RICON® 160/40
120 CS-screws RICON® 5x50 mm
120 CS-screws RICON® 5x80 mm
24 CS-screws RICON® 8x50 mm
24 CS-screws RICON® 8x80 mm
12 locking clips



RICON® is also available in A2 stainless steel up to 17.4 kN and in 13 sizes.

T-JOINT Box

T-JOINT Box - for inclined screw connection

Art.-No. Z606/Box

T-JOINT (Startbox)

50 T-JOINT 20, 25 CS-screws 6x100 mm,
25 CS-screws 6x120 mm,
1 drilling-jig T-JOINT D20, 1 adjustable drilling-jig,
1 HM drill bit 20 mm depth stop, 1 HSS drill bit 6/160 mm

Applications : angle cylinder for flush 30° and 45°
angled screw connections with rigid connections
and and tensile joints.



Beam Hangers

Connecting main / secondary beams
and column up to 39 kN*

- | Timber width up from 60mm
- | Multiple disassembly and reassembly possible
- | High degree of prefabrication for rapid on-site assembly
- | Load-bearing in all directions
- | Short hooking way – only 50 mm
- | Tight joints - self-tightening due to permanent permanent contact pressure
- | Locking clip secures the connection against the slide-in direction (e.g. wind suction)

GIGANT

Available in 3 sizes.

The values only apply when used with original KNAPP® screws! Design values are available on our website under Planer Service.

* Characteristic value $F_{z,Rk}$ in slide-in direction according to ETA 10/0189 (2022/08/25), for hardwood D30 (e.g. oak).



© Christina Wurm, TW Holzbau

GIGANT

- Applications: concealed main-secondary beam connections
- Connection: wood materials e.g. hardwoods (e.g. oak)
- Areas of application: hall construction, timber frame construction, timber frame construction, canopy, pergola



Safe, simple and quick assembly.

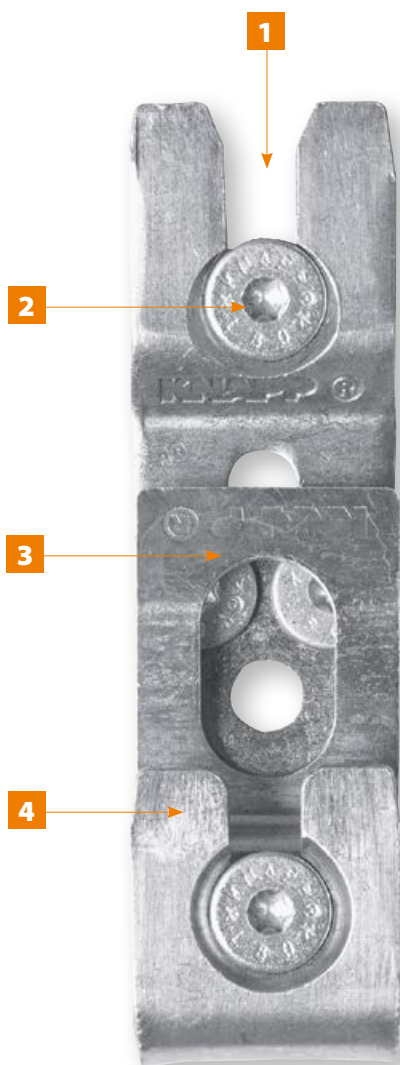

- 1 The dovetail receiving bracket catches the counter bracket and CS-screw with ease, while the angle on the dovetail ensures a self-tightening connection.
- 2 Ø10 mm self-tapping CS-screws guarantee fast installation and the reinforced shank provides an additional strong connection.
- 3 Locking clip latches the connector against the slide-in direction.
- 4 GIGANT is made of premium quality steel and blue galvanized and produced in Austria. Hot-dip galvanizing is available upon request.

Fire rating: Fire resistance (EN 1995-1-2) through 3-4 sided concealed, joint-tight installation (R30 ≥ 28 mm, R60 ≥ 49 mm)



GIGANT 120/40

Application examples and connection details

Art.-No. K051

(Dimensions in mm)

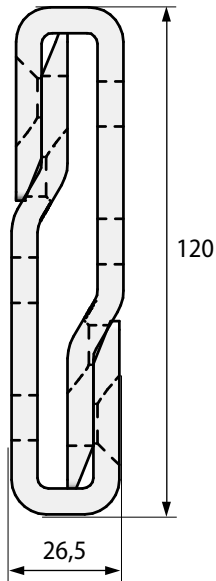

Connector	Connection	Screw connection		Charact. values [GL24h]	
		Joint	Header	F _{1,Rk} [kN]	F _{2,Rk} [kN]
120/40	without locking clip	3 x CS 10x120	3 x CS 10x80	12,5	12,5
120/40	without locking clip	3 x CS 10x200	3 x CS 10x80	14,0	12,5
120/40	with locking clip	3 x CS 10x120	3 x CS 10x80	12,5	12,5

Clip lock: F_{3,Rk} = 12,0 kN

Minimum timber dimensions with/without locking clip: 60 x 150 mm

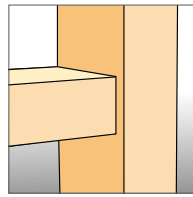

Single connection for post-latch connections

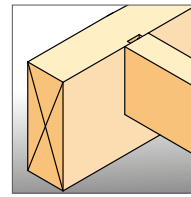

Single connection:
Header thickness from 100 mm;
Joint thickness from 60 mm

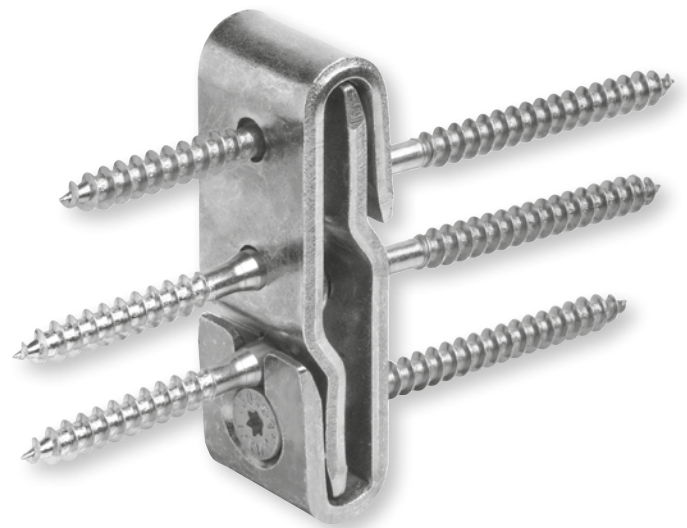
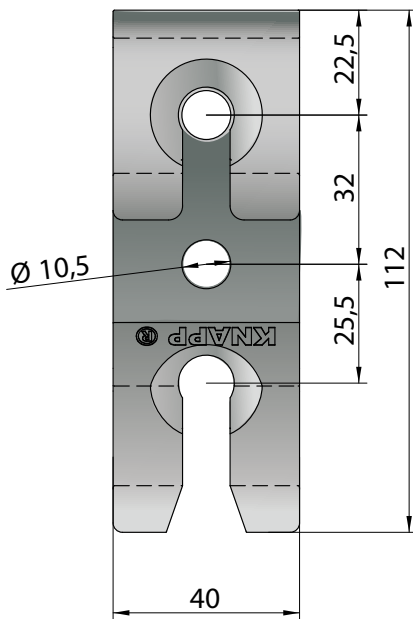

Standard screw connection without locking clip

GIGANT locking clip

Functionality of the locking clip (galvanized steel plate)

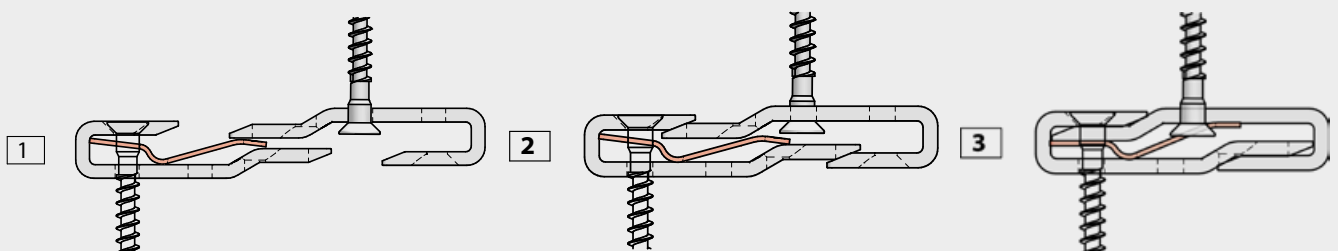

GIGANT 150/40

Application examples and connection details

Art.-No. K050

(Dimensions in mm)

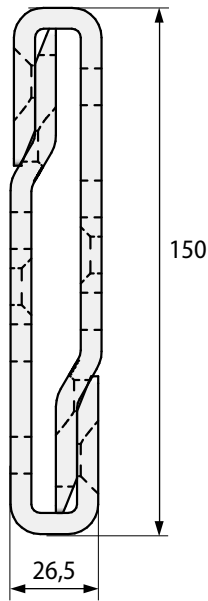

Connector	Connection	Screw connection		Charact. values [GL24h]	
		Joint	Header	$F_{1,Rk}$ [kN]	$F_{2,Rk}$ [kN]
150/40	without locking clip	4 x CS 10x120	4 x CS 10x80	12,5	16,7
150/40	without locking clip	4 x CS 10x200	4 x CS 10x80	14,0	19,2
150/40	with locking clip	4 x CS 10x120	4 x CS 10x80	12,5	16,7

Clip lock: $F_{3,Rk} = 12,0$ kN

Minimum timber dimensions without locking clip: 80 x 200 mm

Minimum timber dimensions with locking clip: 60 x 200 mm

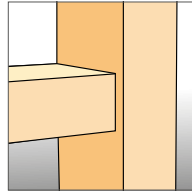

Single connection for post-latch connections

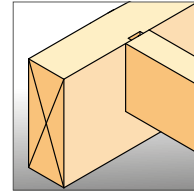

Single connection:
Header thickness from 100 mm;
Joint thickness from 60 mm

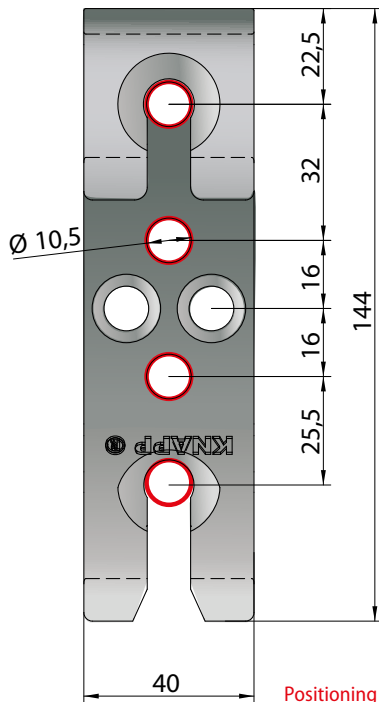

Positioning of screws in the centre when using the locking clip



Standard screw connection without locking clip

GIGANT locking clip

Functionality of the locking clip (galvanized steel plate)

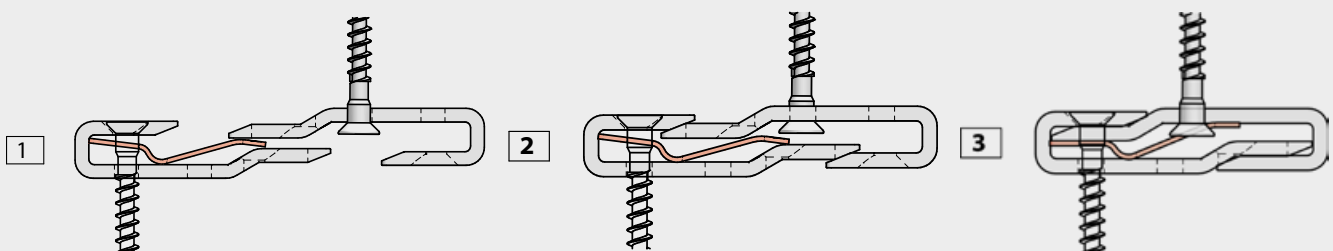

GIGANT 180/40

Application examples and connection details

Art.-No. K052
(Dimensions in mm)

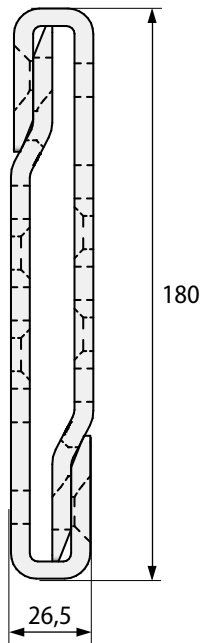

Connector	Connection	Screw connection		Charact. values [GL24h]	
		Joint	Header	F _{1,Rk} [kN]	F _{2,Rk} [kN]
180/40	without locking clip	6 x CS 10x120	6 x CS 10x80	12,5	25,0
180/40	without locking clip	6 x CS 10x200	6 x CS 10x80	14,0	30,7
180/40	with locking clip	5 x CS 10x120	6 x CS 10x80	12,5	20,8

Clip lock: F_{3,Rk} = 12,0 kN

Minimum timber dimensions without locking clip: 80 x 200 mm
Minimum timber dimensions withlocking clip: 60 x 200 mm

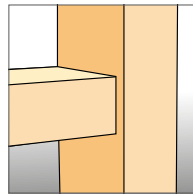

Single connection for post-latch connections

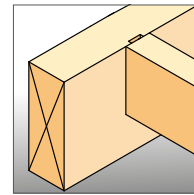

Single connection:
Header thickness from 100 mm;
Joint thickness from 60 mm

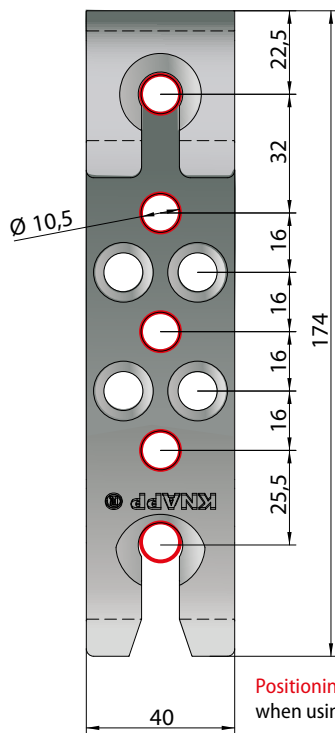

Positioning of screws in the centre when using the locking clip



Standard screw connection without locking clip

GIGANT locking clip

Functionality of the locking clip (galvanized steel plate)

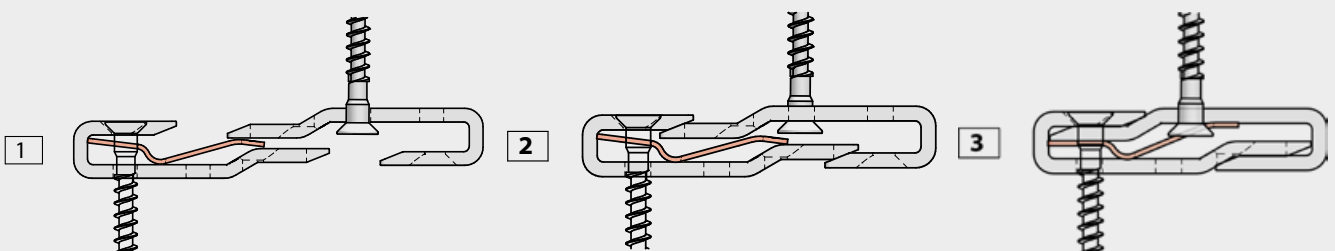

GIGANT 150/40 and 180/40 wood to concrete connection

Wood to concrete connection with injection mortar

(Dimensions in mm)

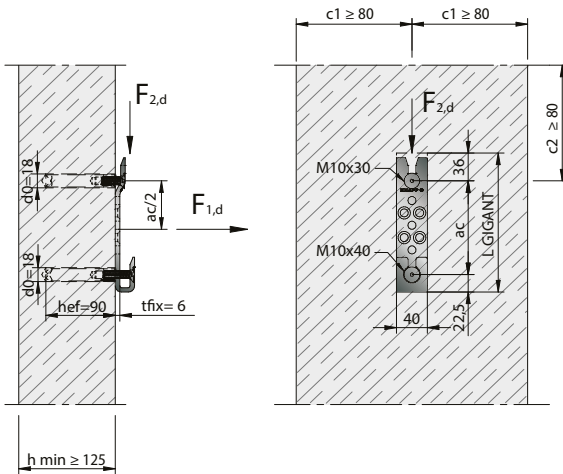

Concrete C20/25

fischer RG 16x90 M10 I (8.8) with CS M10x30 and CS M10x40 (zinc plated steel)

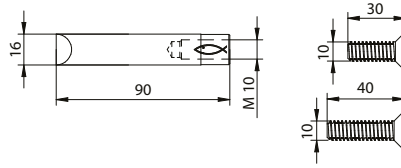

CS M10x30 with hexagon socket

CS M10x40 with hexagon socket

fischer Superbond-System: FIS SB 390 S

Drill hole diameter d_0	= 18 mm
Drill hole depth h_1	= 90 mm
Total fixing thickness t_{fix}	= 6 mm
Spacing a_c	= see table below
Minimal edge distance $c_{1,min} = c_{2,min}$	= 80 mm
Minimal concrete wall thickness h_{min}	= 125 mm
Approval:	ETA-12/0258



F_2 Load direction in the direction of insertion

KNAPP® Connectors	Concrete connection		Timber connection											
	$F_{2,Rd,concrete}$	Distances	Wood material		$F_{2,Rd,timber}$									
	Shear force $F_{2,Rd,concrete}$ [kN]	Dowel spacing a_c [mm]	Wood type	Char. density ρ_k [kg/m³]	Charact. values [kN]		Design values $F_{2,Rd} \cdot Y_M = 1,3$ [kN]							
					$F_{2,KCC,Rk} \cdot Y_M = 1,0$	$F_{2,Rk}$	$k_{mod} = 0,6$	$k_{mod} = 0,8$	$k_{mod} = 0,9$					
GIGANT 150/40 * Concrete: 2 RG M10 I	18,00	90	C24	350	24,0	15,4	7,1	9,5	10,7					
			GL24h	385										
GIGANT 150/40 max ** Concrete: 2 RG M10 I	18,00	90	C24	350						33,0	17,7	8,2	10,9	12,3
			GL24h	385										
GIGANT 180/40 * Concrete: 2 RG M10 I	22,00	122	C24	350	23,1	10,7	14,2	16,0						
			GL24h	385										
GIGANT 180/40 max ** Concrete: 2 RG M10 I	22,00	122	C24	350					25,0	11,5	15,4	17,3		
			GL24h	385										
			C24	350	28,3	13,1	17,4	19,6						
			GL24h	385										
			C24	350					30,7	14,2	18,9	21,3		
			GL24h	385										

* GIGANT standard screw connection in end-grain with CS-screws 10x120

** GIGANT maximal screw connection in end-grain with CS-screws 10x200

Service class timber: 1-2

$Y_{M,timber} = 1,3$

Calculation of $F_{2,Rd}$ for timber-concrete connection:

$$F_{2,Rk} = \min \left\{ \begin{array}{l} \min F_{2,Rd,timber} \\ \min F_{2,Rd,concrete} \end{array} \right.$$

$$F_{2,Rk,timber} = \min \left\{ \begin{array}{l} \min F_{2,KCC,Rk} / Y_M \\ \min F_{2,Rk} \cdot k_{mod} \\ Y_{M,timber} \end{array} \right.$$

Notes

The fischer anchors for KNAPP® wood-concrete connections were defined with the dimensions shown on the drawings and a concrete strength class of C20/25. The calculations were made with the C-FIX design tool and verified by fischer. All other configurations must be checked. This can be done by KNAPP®, fischer or a professional (engineer or competent technician). KNAPP® accepts no liability for the inappropriate use of the value tables given in this catalogue. The condition of the concrete element (concrete strength class and surface) must be checked by a specialist. KNAPP® accepts no liability in this respect. KNAPP® products and connectors must be installed according to the installation instructions manuals. KNAPP® - fischer wood-concrete joints must be made in accordance with their respective ETA technical evaluations.

Equivalent anchoring solutions (e.g. Hilti,...) permitted if technically tested beforehand by a qualified design professional and have a European Technical Assessment.

Header-joist connection with bolt anchor

(Dimensions in mm)

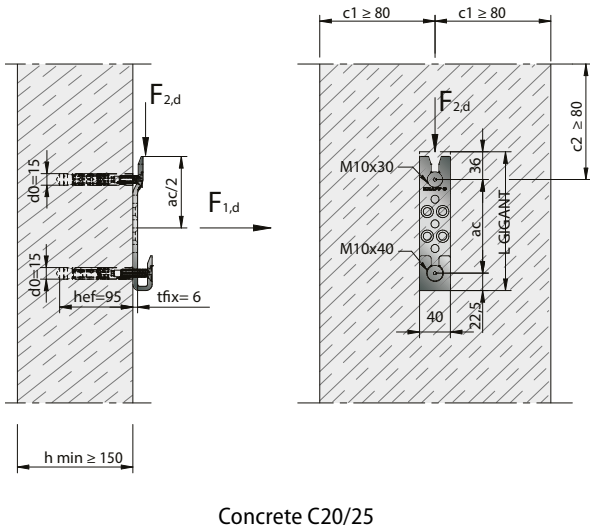

fischer RG 16x90 M10 I (8.8) with CS M10x30 and CS M10x40 (zinc plated steel)

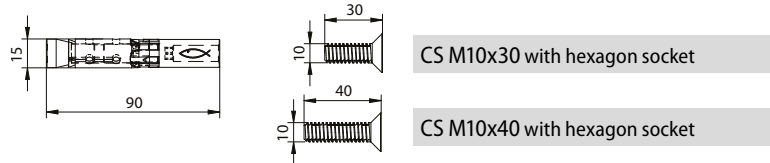

Drill hole diameter d_0	= 15 mm
Drill hole depth h_1	= 95 mm
Total fixing thickness t_{fx}	= 6 mm
Spacing a_c	= see table below
Minimal edge distance $c_{1,min} = c_{2,min}$	= 80 mm
Minimal concrete wall thickness h_{min}	= 150 mm
Approval:	ETA-07/0025, Option 1

F_2 Load direction in the direction of insertion

KNAPP® Connectors	Concrete connection		Timber connection						
	$F_{2,Rd,concrete}$	Distances	Wood material		$F_{2,Rd,timber}$				
	Shear force $F_{2,Rd,concrete}$ [kN]	Dowel spacing a_c [mm]	Wood type	Char. density ρ_k [kg/m³]	Charact. values [kN]		Design values $F_{2,Rd, Y_M = 1,3}$ [kN]		
					$F_{2,KCC,Rk} \cdot Y_M = 1,0$	$F_{2,Rk}$	$k_{mod} = 0,6$	$k_{mod} = 0,8$	$k_{mod} = 0,9$
GIGANT 180/40 * Concrete: 2 RG M10 I	21,00	122	C24	350	33,0	23,1	10,7	14,2	16,0
			GL24h	385		25,0	11,5	15,4	17,3
GIGANT 180/40 max ** Concrete: 2 RG M10 I	21,00	122	C24	350	33,0	28,3	13,1	17,4	19,6
			GL24h	385		30,7	14,2	18,9	21,3

* GIGANT standard screw connection in end-grain with CS-screws 10x120

** GIGANT maximal screw connection in end-grain with CS-screws 10x200

Service class timber: 1-2

$Y_{M,timber} = 1,3$

Calculation of $F_{2,Rd}$ for timber-concrete connection:

$$F_{2,Rk} = \min \left\{ \begin{array}{l} \min F_{2,Rd,timber} \\ \min F_{2,Rd,concrete} \end{array} \right. \quad F_{2,Rk,timber} = \min \left\{ \begin{array}{l} \min F_{2,KCC,Rk} / Y_M \\ \min F_{2,Rk} \cdot k_{mod} \\ Y_{M,timber} \end{array} \right.$$

Notes

The fischer anchors for KNAPP® wood-concrete connections were defined with the dimensions shown on the drawings and a concrete strength class of C20/25. The calculations were made with the C-FIX design tool and verified by fischer. All other configurations must be checked. This can be done by KNAPP®, fischer or a professional (engineer or competent technician). KNAPP® accepts no liability for the inappropriate use of the value tables given in this catalogue. The condition of the concrete element (concrete strength class and surface) must be checked by a specialist. KNAPP® accepts no liability in this respect. KNAPP® products and connectors must be installed according to the installation instructions manuals. KNAPP® - fischer wood-concrete joints must be made in accordance with their respective ETA technical evaluations.

Equivalent anchoring solutions (e.g. Hilti,...) permitted if technically tested beforehand by a qualified design professional and have a European Technical Assessment.

GIGANT wood to steel connection

Main and secondary beam and post and beam connections.

(Dimensions in mm)

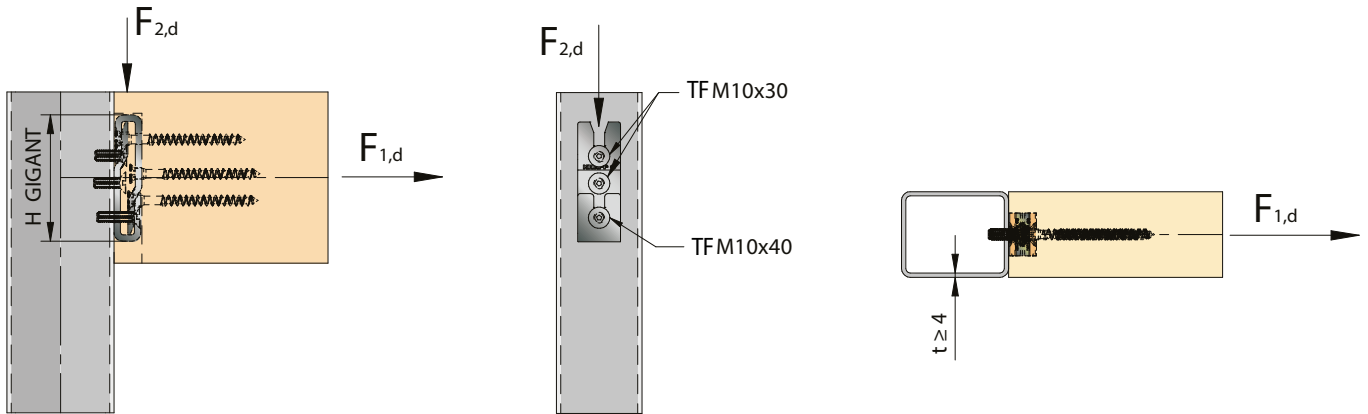

KNAPP® Connectors	Traction		Shear force	
	$F_{t,Rk}$ [kN]* on 4 mm steel	$F_{t,Rk}$ [kN]* on glulam GL24h	$F_{v,Rk}$ [kN]* on 4 mm steel	$F_{2,Rk}$ [kN]* on glulam GL24h
GIGANT 120/40 *	57,0	12,5	38,4	12,5
GIGANT 120/40 max **		14,0		12,5
GIGANT 150/40 *		12,5		16,7
GIGANT 150/40 max **		14,0		19,2
GIGANT 180/40 *		12,5		25,0
GIGANT 180/40 max **		14,0		30,7
Sizing value calculation	$F_{t,Rd} = F_{t,Rk} / Y_{M,2}$	$F_{t,Rd} = k_{mod} \times F_{t,Rk} / Y_M$	$F_{v,Rd} = F_{v,Rk} / Y_{M,2}$	$F_{1,Rd} = k_{mod} \times F_{1,Rk} / Y_M$
	$Y_{M,2} = 1,25$	$Y_M = 1,3$	$Y_{M,2} = 1,25$	$Y_M = 1,3$
		$k_{mod} = 0,8$ LDC medium		$k_{mod} = 0,8$ LDC medium
		$k_{mod} = 0,9$ LDC short		$k_{mod} = 0,9$ LDC short
Screw connection *	2 CS M10x30	End-grain screw connection	2 CS M10x30	End-grain screw connection
	1 CS M10x40	Self-tapping CS-screw 10x120 / CS 10x200 for max	1 CS M10x40	CS 10x120 / CS 10x200 for max

* GIGANT standard screw connection in end-grain with CS 10x120

** GIGANT maximal screw connection in end-grain with CS 10x200

Service class timber: 1-2

Case studies



GIGANT

Installation

Manufacturing with CNC joinery machine is possible – all datas are available on the standard CNC joinery machine programs.
Milling with KNAPP® routing-jig.



Mill



Pre-drill header



Screw on connector



Pre-drill secondary beam



Screw on connector



Optionally installed with locking clip



Easy assembling without jamming



GIGANT routing dimension		
Width	Length	Depth
40 mm	variable	26,5 mm

Recommended software partners for machine processing:



Vis GIGANT

KNAPP® self-tapping CS-screws with reinforced shaft
(GIGANT comes in a set including CS-screws)

Art.-No. Z523	CS-screw 10x80
Art.-No. Z524	CS-screw 10x120 (end grain and CLT)
Art.-No. Z583	CS-screw 10x200

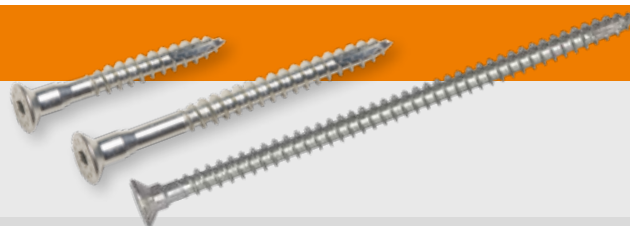

Application: pour le vissage de GIGANT sur les poutres principales (poteaux) ou secondaires (traverses).

GIGANT

GIGANT locking clip (galvanized steel plate)

Art.-No. Z525	GIGANT Locking Clip
---------------	---------------------



Application: to latch the connection against the slide-in direction.

GIGANT accessories

Routing-jig for all GIGANT sizes

Art.-No. K502	MULTI F40 Routing-jig (plywood)
---------------	---------------------------------

Note: The MULTI F40 routing template is designed for the use of a Ø30 mm copying sleeve (for router) and a Ø15 mm TCT straight router bit. MULTI F is adjustable depending on wood sizes.

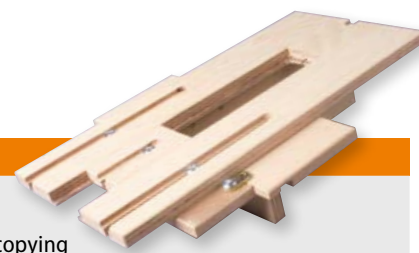

Application: for milling the pocket to recess GIGANT.

TCT slotting cutter

Art.-No. Z068	TCT straight slotting bit with Ø15 mm, 40 mm length and Ø12 mm shank
---------------	--

Application: for milling the pocket to recess GIGANT.



GIGANT drilling-jig (galvanized steel)

Art.-No. K631	Drilling-jig guide GIGANT 120
Art.-No. K632	Drilling-jig guide GIGANT 150
Art.-No. K633	Drilling-jig guide GIGANT 180

Application: place into MULTI F routing jig for exact positioning and pre-drilling of GIGANT CS-screws.



GIGANT drilling-jig (adjustable)

Art.-No. K463	Drilling-jig GIGANT 120
Art.-No. K464	Drilling-jig GIGANT 150
Art.-No. K465	Drilling-jig GIGANT 180

Jig with hardened drill bushes for Ø6 mm

Application: for pre-drilling of GIGANT CS-screws.



Connectors for timber construction engineering

Connecting main and secondary beams up to 230 kN*

- | Minimum timber width up from 100 mm
- | Multiple disassembly and reassembly possible
- | High degree of prefabrication for industrial production
- | Simple screw connection without pre-drilling
- | Can be assembled crosswise, lengthwise and diagonally
- | Assembly made easy due to V-shaped bracket and only 35 mm hook way
- | Installation tolerances due to adjustable collar bolts
- | Three- and four-sided concealed connection
- | Secured connection against the direction of insertion with matching locking clip

RICON[®]S

Available in 5 sizes and 4 versions.

The values only apply when used with original KNAPP[®] screws! Design values are available on our website under Planer Service.

* Characteristic value $F_{z,Rk}$ in slide-in direction according to ETA 10/0189 (2022/08/25), for hardwood D30 (e.g. oak).



© Huf Haus



© Rührer

Installation example: pillar connection, Sky project, Sophia in the South of France.

RICON®S

- | Applications: concealed main-secondary beam connections.
- | Connections: wood to wood, wood to steel, steel to steel, and wood to concrete
- | Applications: timber engineering, timber frame, timber frame and hall construction
- | Service class 1 and 2

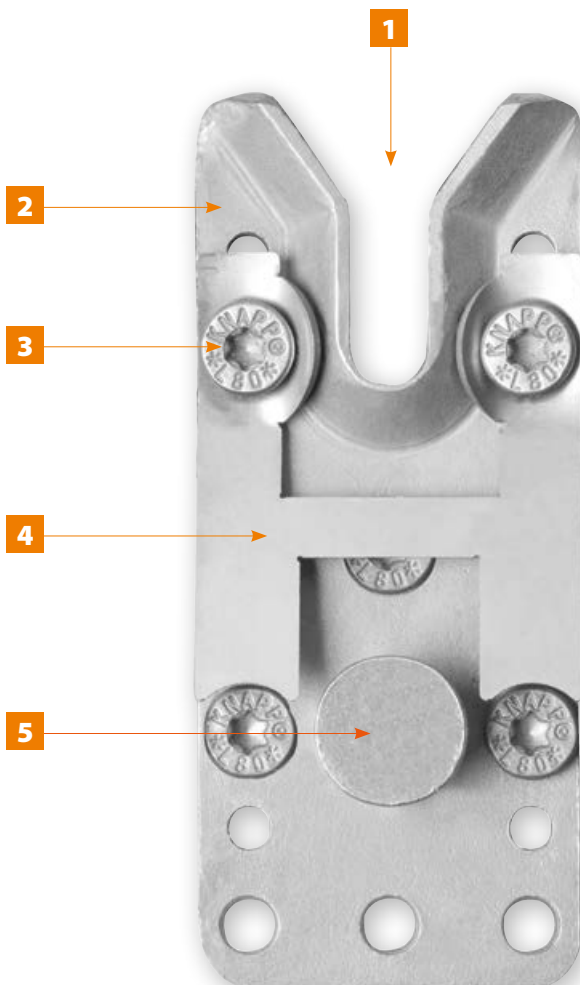

- 1** The V-shaped receiver provides perfect catch of the collar bolt. The strong tension and the short slide-in alleviates the connecting and guarantees joint sealing.
- 2** RICON® S is made of premium quality steel, hot-dip galvanized and produced in Germany.
- 3** KNAPP® CS-screws with cut point for extra fast starting and screw connection. The reinforced shaft provides a force-fit connection.
- 4** The RICON®S locking clip, made from stainless spring steel, locks the connection against slide-in direction and can optionally be used for stress against slide-in direction or wind suction.
- 5** VS = welded collar bolt, for highest load capacities
 EK = retaining screw collar bolt, for tolerance adjustment
 VK = screwed collar bolt, for moderate charge capacities
 GK = spring-loaded collar bolt for special assembly requirements

Fire rating: Fire resistance (EN 1995-1-2) through 3-4 sided concealed, joint-tight installation (R30 ≥ 28 mm, R60 ≥ 49 mm)

made
in
Germany



ETA ETA-10/0189
(2022/08/25)



RICON®S

RICON®S

RICON®S Standard Sizes

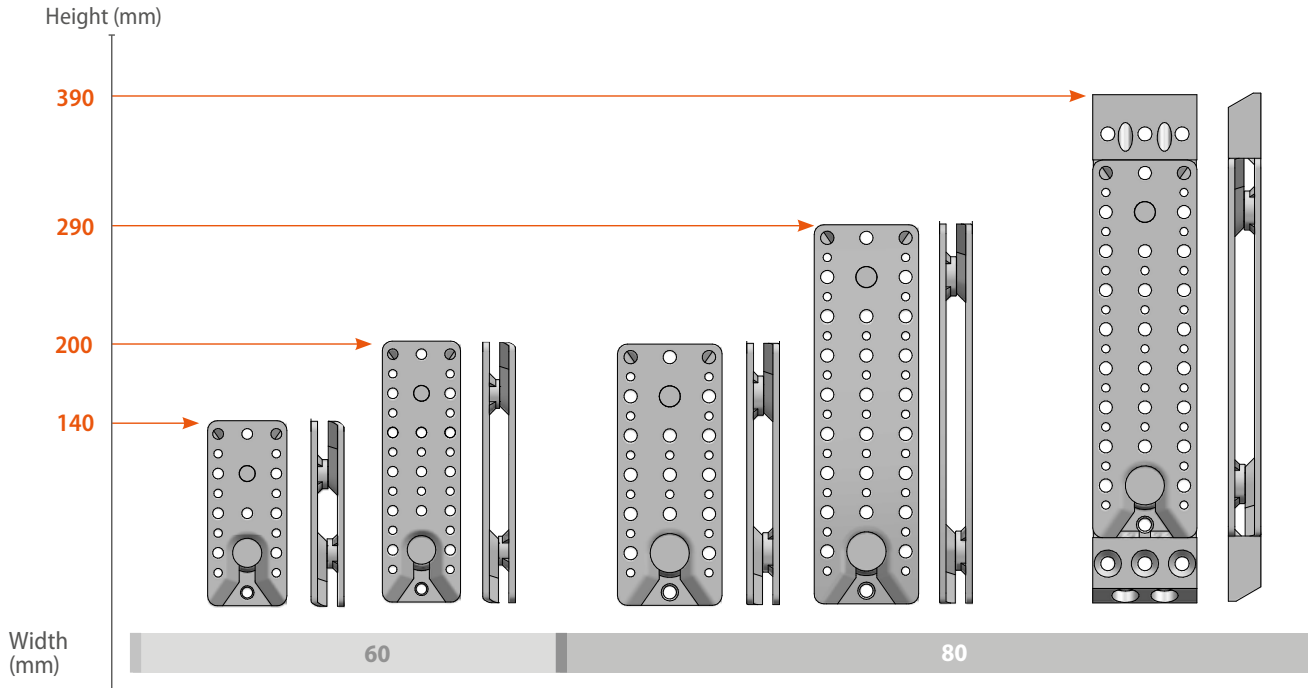

RICON®S views

Top view of RICON®S collar bolt versions

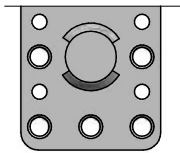

Welded collar bolt

VS

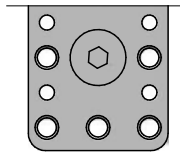

Adjustable collar bolt

EK

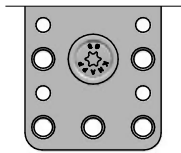

Screwed collar bolt

VK

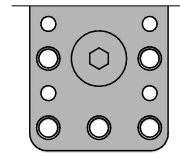

Spring-loaded collar bolt

GK

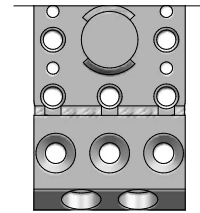

Welded collar bolt XL version

VS + ZP

Side view of RICON®S collar bolt



Welded collar bolt (VS)

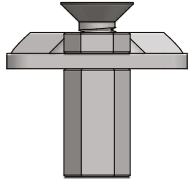

Adjustable collar bolt (EK)

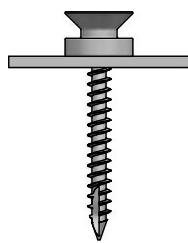

Screwed collar bolt (VK)

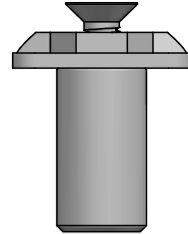

Spring-loaded collar bolt (GK)

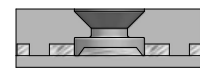

Welded collar bolt XL version

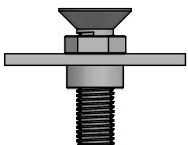

Adjustable collar bolt S80 with insert screw

RICON® S

Application examples and connection details

Ridged roof with purlins and post and beam connections

(Dimensions in mm)

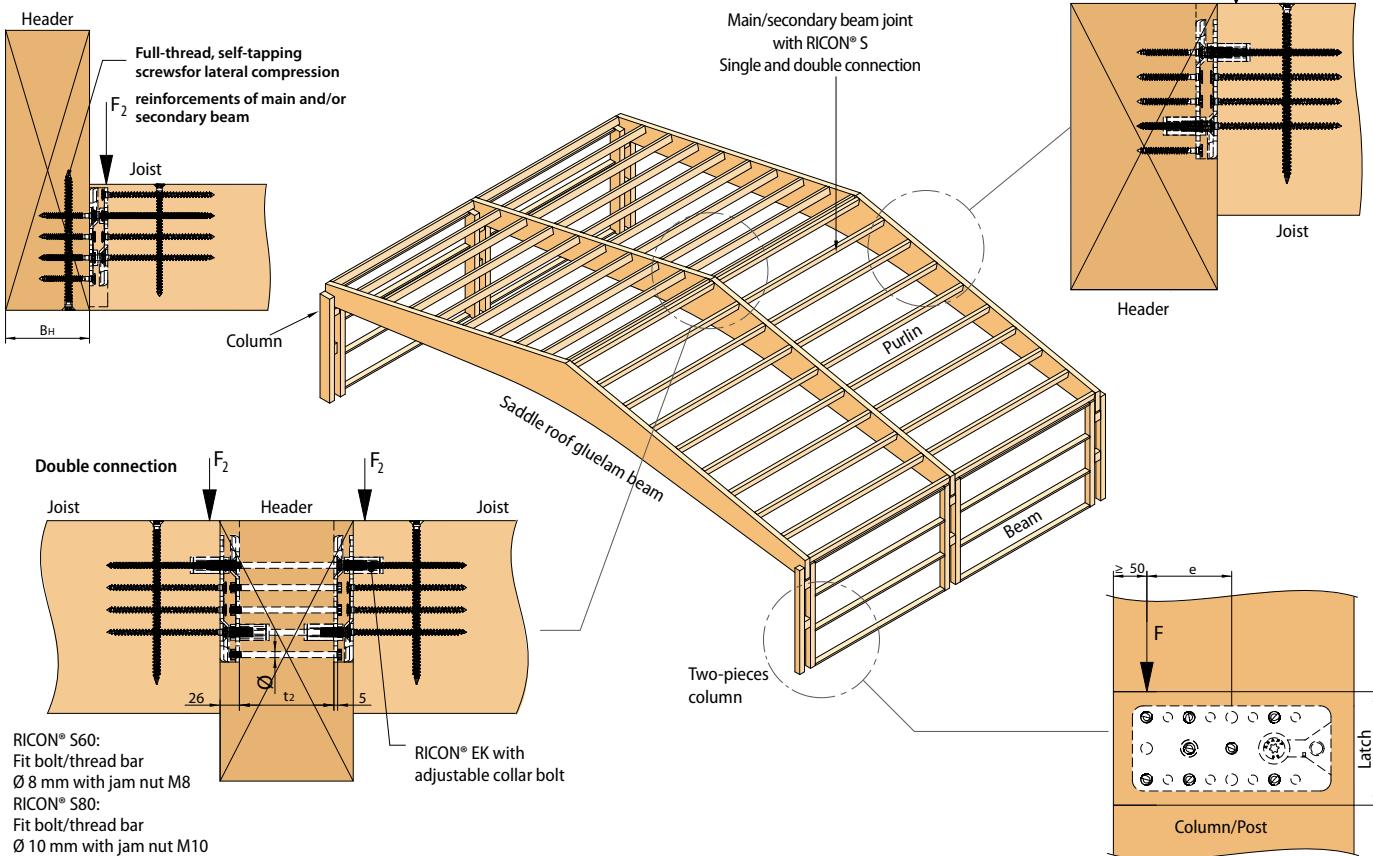

© Charpenterie S. Hinrichsen (DE)

Hall roof of carpentry S. Hinrichsen (Germany)

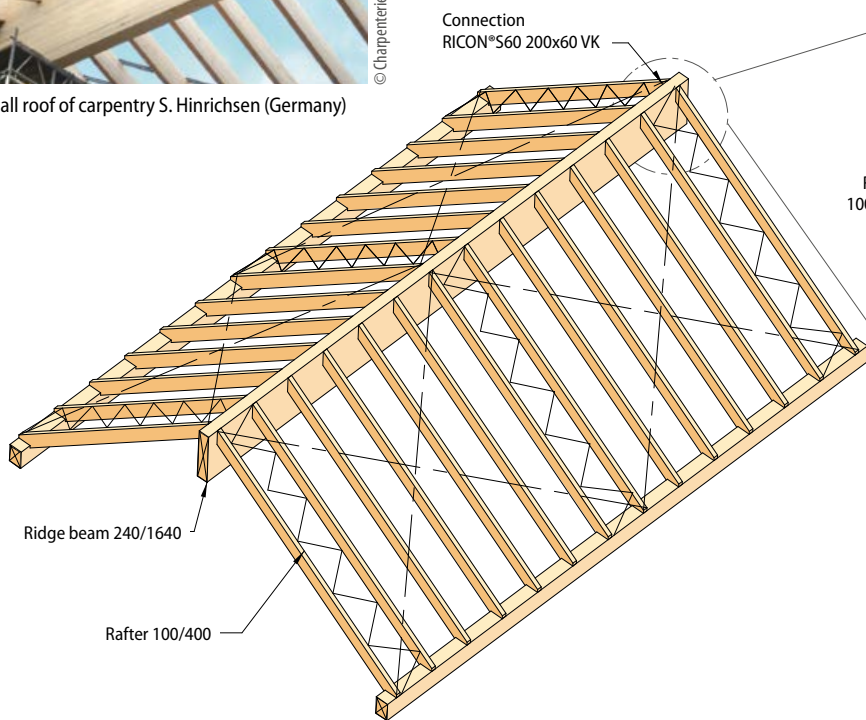

RICON® S housed into a rafter - totally concealed

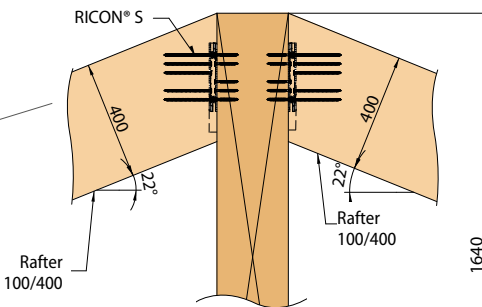

RICON® S housed into the ridge beam - totally concealed

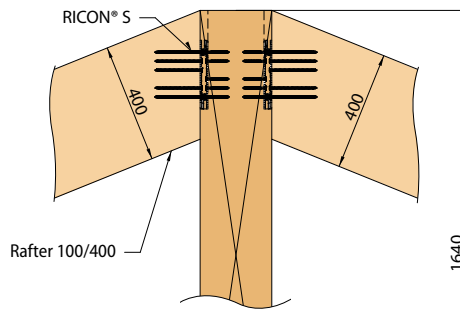

RICON® S

Timber engineering

Connecting header with timber frame construction or cross-laminated timber wall

(Dimensions in mm)

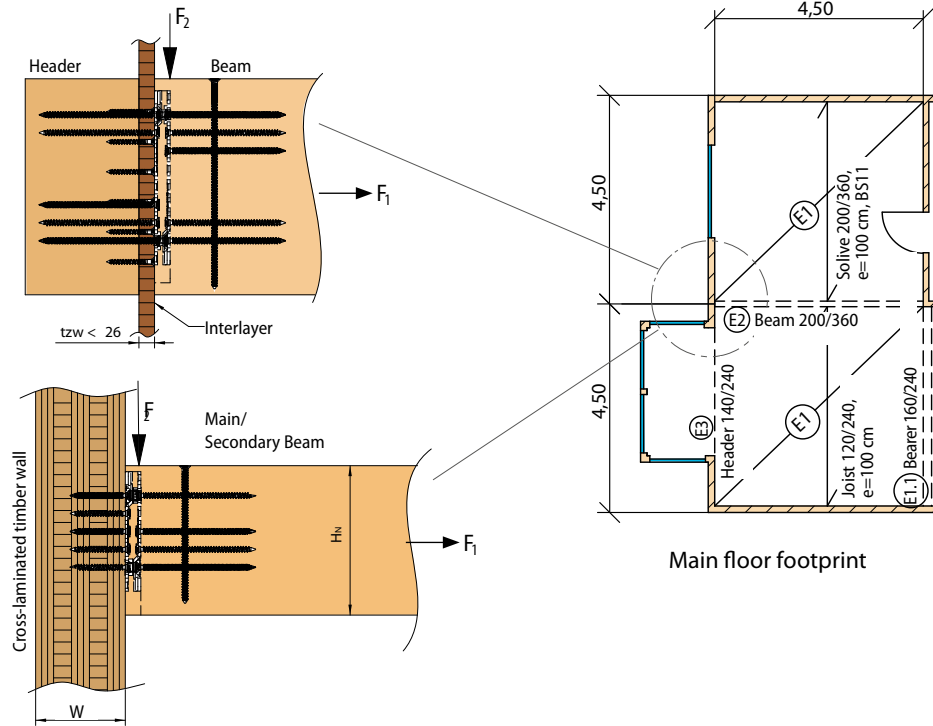

Steel connection



▮ Ridge node for dome

Ceiling of a timber frame construction

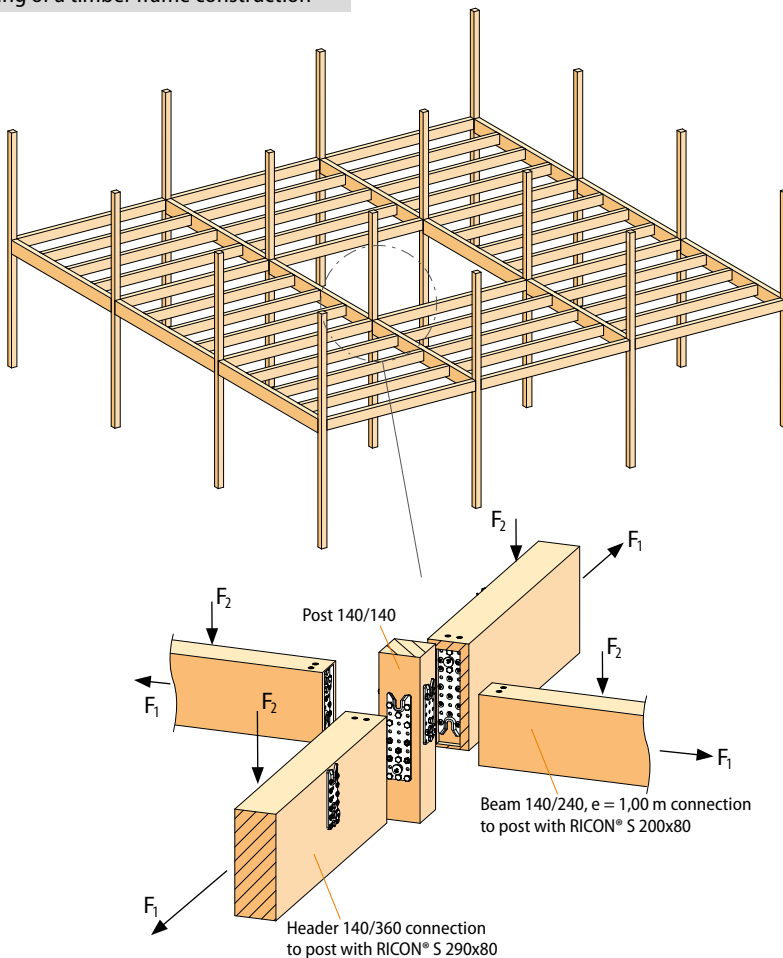

Alternative ways to connect

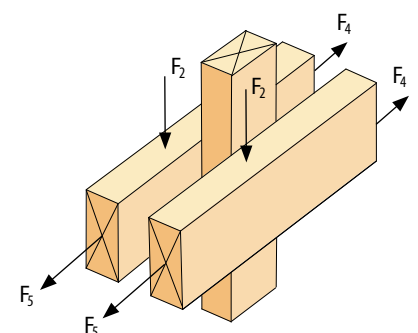
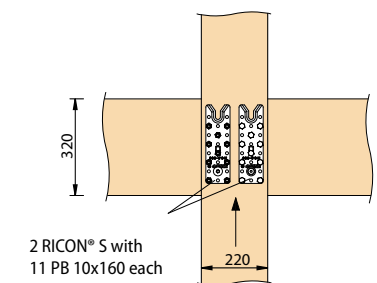
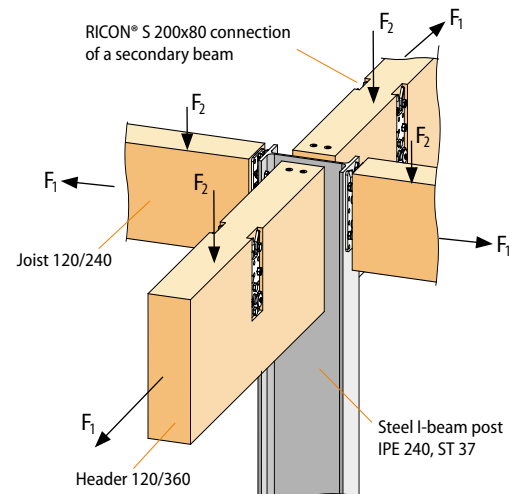

RICON® S 60 VS

RICON® S 140/60 VS - Welded collar bolt header-joist connection

Art.-No.K126

(Dimensions in mm)

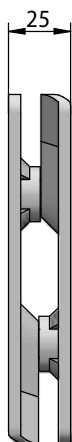
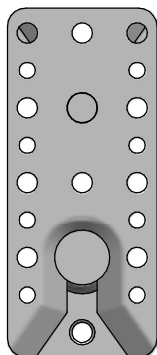

Art.-No.	RICON® S	Collar bolt	Screw connection		Charact. values [GL24h] $F_{2,Rk}$ [kN]
			Joist	Header	
K126 MIN ●	140/60	VS	7 x CS 8x160	7 x CS 8x80	26.9
K126 ST	140/60	VS	10 x CS 8x160	10 x CS 8x80	37.1
K126 MAX	140/60	VS	10 x CS 8x240	10 x CS 8x80	40.2
Axial tension: $F_{1,Rk} = 31.5$ kN					
Clip lock: $F_{3,Rk} = 18.0$ kN					

MIN = minimum screw cxn. ST = standard screw cxn.

Min. timber cross-section: 100 x 160 mm

All design values are available on our website under the Planner Service tab.

Welded collar bolt

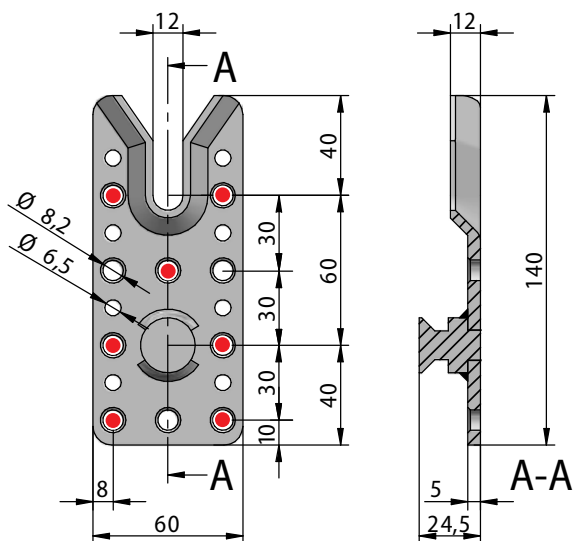
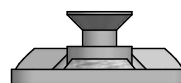

PRODUCT

RICON® S locking clip

RICON® S 60 locking clip (made of stainless spring steel)

Art.-No.K157

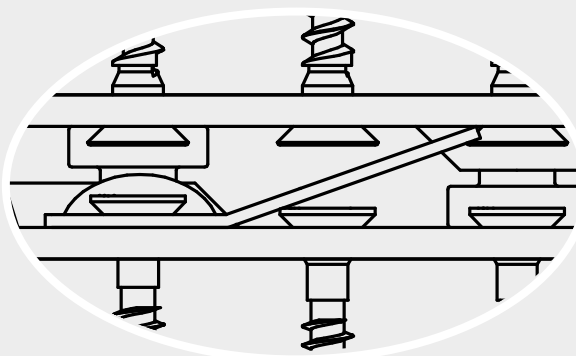
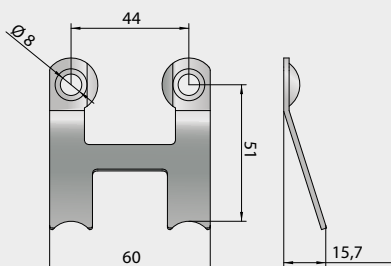

Application: the locking clip locks the connection against slide-in direction and is used for stress against slide-in direction or wind suction.

RICON®S 140/60 VS - Welded collar bolt post connection

Art.-No. K126

(Dimensions in mm)



Art.-No.	RICON® S	Collar bolt	Screw connection		Charact. values [GL24h] $F_{2,Rk}$ [kN]
			Joist	Column	
K126 MIN ●	140/60	VS	6 x CS 8x80	10 x CS 8x160	27.2
K126 ST	140/60	VS	8 x CS 8x80	10 x CS 8x160	29.7
Axial tension: $F_{1,Rk} = 31.5$ kN					
Clip lock: $F_{3,Rk} = 18.0$ kN					

MIN = minimum screw cxn. ST = standard screw cxn.

Min. timber cross-section: MIN = 100 x 100 mm ST = 120 x 120 mm

All design values are available on our website under the Planner Service tab.

Welded collar bolt

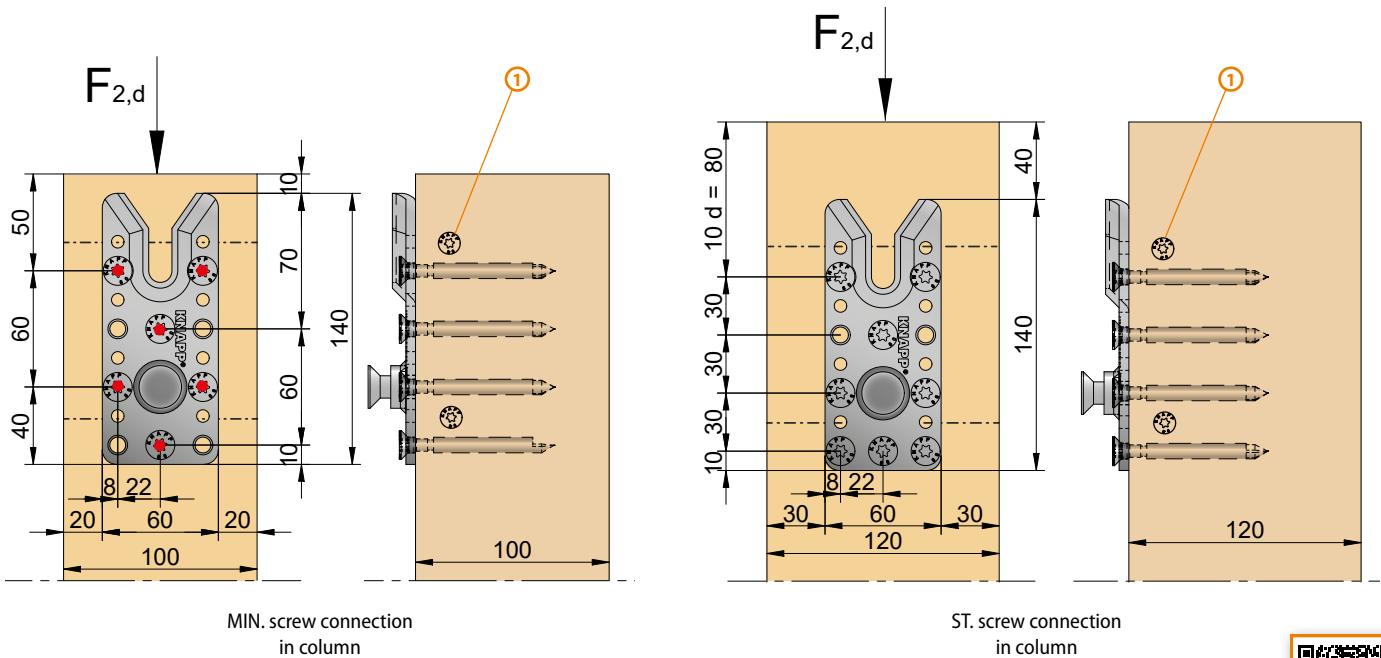
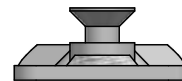

① Arrangement of fully threaded screws for transverse tensile reinforcement. According to the expert opinion (10.09.2021) of Prof. Dr. Blaß, the transverse tensile bolts should have the same screw diameter as the RICON®S screws used. These bolts should have the same length as the column cross-section width.



RICON®S locking clip

RICON®S 60 locking clip (made of stainless spring steel)

Art.-No. K157

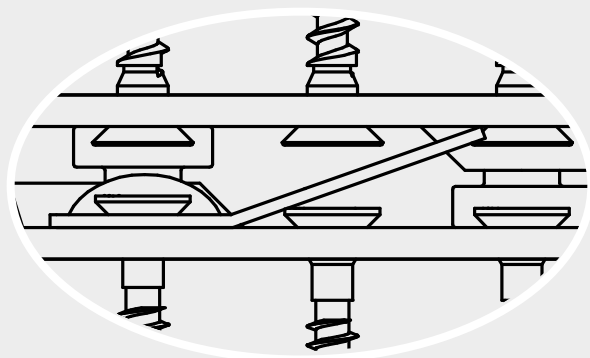
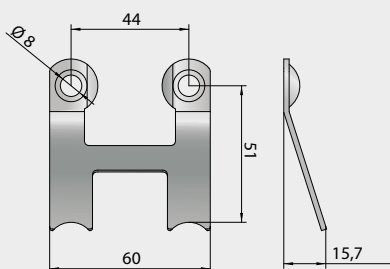

Application: the locking clip locks the connection against slide-in direction and is used for stress against slide-in direction or wind suction.

RICON®S 140/60 VS - Welded collar bolt double post connection

Art.-No.K126

(Dimensions in mm)



Art.-No.	RICON® S	Collar bolt	Screw connection		Charact. values [GL24h] $F_{2,Rk}$ [kN]
			Joist	Column	
K126 ST	2x 140/60	VS	16x CS 8x80	20x CS 8x160	57.6
Axial tension: $F_{1,Rk} = 63$ kN					
2 clip locks: $F_{3,Rk} = 36$ kN					

ST = standard screw cxn.

All design values are available on our website under the Planner Service tab.

Welded collar bolt

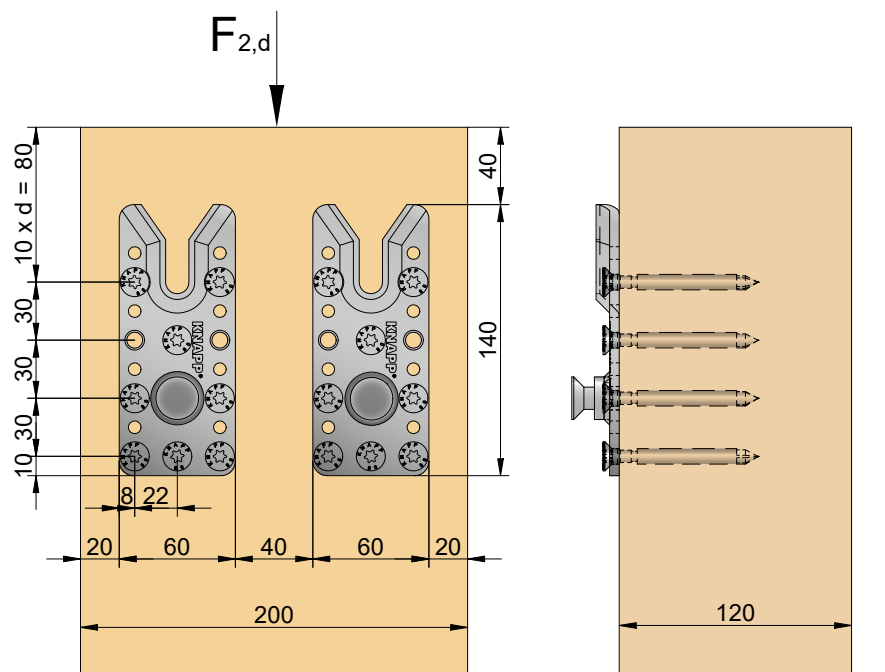
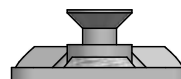

PRODUCT

RICON®S locking clip

RICON®S 60 locking clip (made of stainless spring steel)

Art.-No.K157

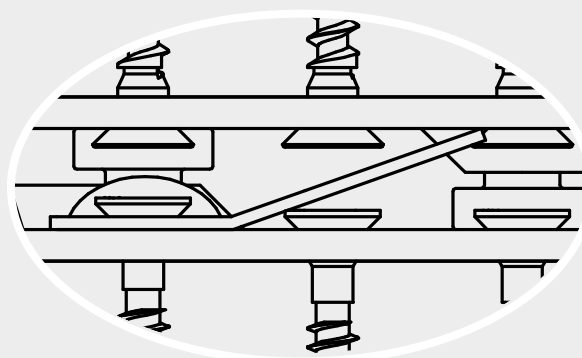
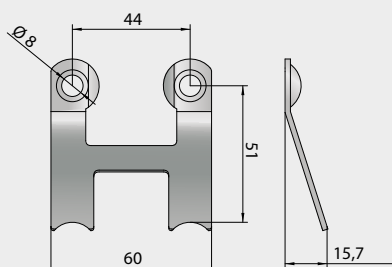

Application: the locking clip locks the connection against slide-in direction and is used for stress against slide-in direction or wind suction.

RICON® S 200/60 VS - Welded collar bolt header-joist connection

Art.-No.K127

(Dimensions in mm)

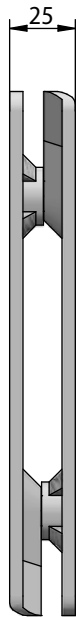
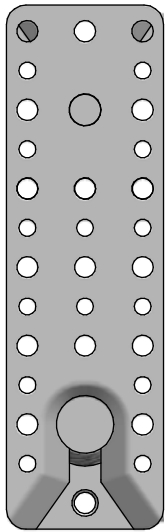

Art.-No.	RICON® S	Collar bolt	Screw connection		Charact. values [GL24h] $F_{2,Rk}$ [kN]
			Joist	Header	
K127 MIN ●	200/60	VS	8 x CS 8x160	8 x CS 8x80	30.4
K127 ST	200/60	VS	16 x CS 8x160	16 x CS 8x80	56.7
K127 MAX	200/60	VS	16 x CS 8x240	16 x CS 8x80	66.5
Axial tension: $F_{1,Rk} = 31.5$ kN					
Clip lock: $F_{3,Rk} = 18.0$ kN					

MIN = minimum screw cxn. ST = standard screw cxn. MAX = maximum screw cxn.

Min. timber cross-section: 100 x 220 mm

All design values are available on our website under the Planner Service tab.

Welded collar bolt

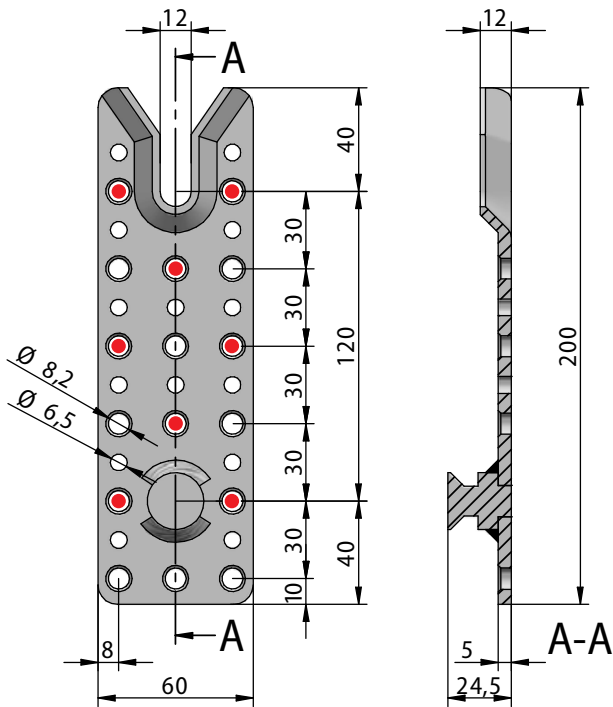
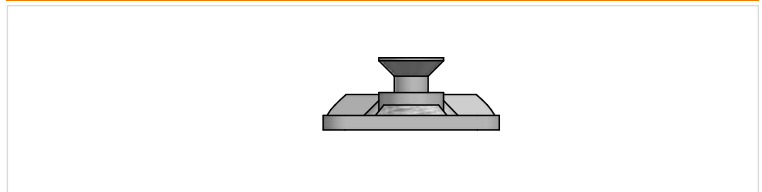

RICON® S locking clip

RICON® S 60 locking clip (made of stainless spring steel)

Art.-No.K157

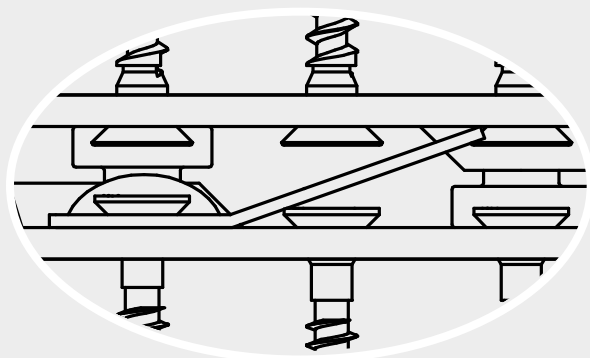
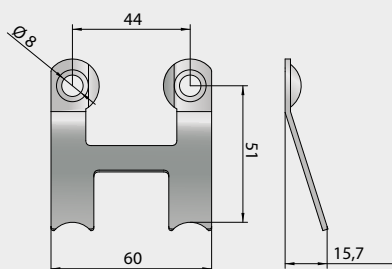

Application: the locking clip locks the connection against slide-in direction and is used for stress against slide-in direction or wind suction.

RICON®S 200/60 VS - Welded collar bolt post connection

Art.-No.K127

(Dimensions in mm)



Art.-No.	RICON® S	Collar bolt	Screw connection		Charact. values [GL24h] $F_{2,Rk}$ [kN]
			Joist	Column	
K126 MIN ●	200/60	VS	9 x CS 8x80	16 x CS 8x160	43.0
K126 ST	200/60	VS	13 x CS 8x80	16 x CS 8x160	51.7
Axial tension: $F_{1,Rk} = 31.5$ kN					
Clip lock: $F_{3,Rk} = 18.0$ kN					

MIN = minimum screw cxn. ST = standard screw cxn.

Min. timber cross-section: MIN = 100 x 100 mm ST = 120 x 120 mm

All design values are available on our website under the Planner Service tab.

Welded collar bolt

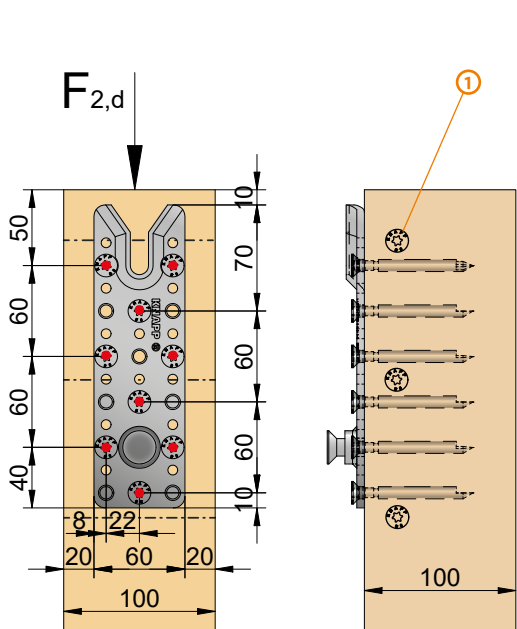
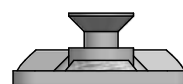
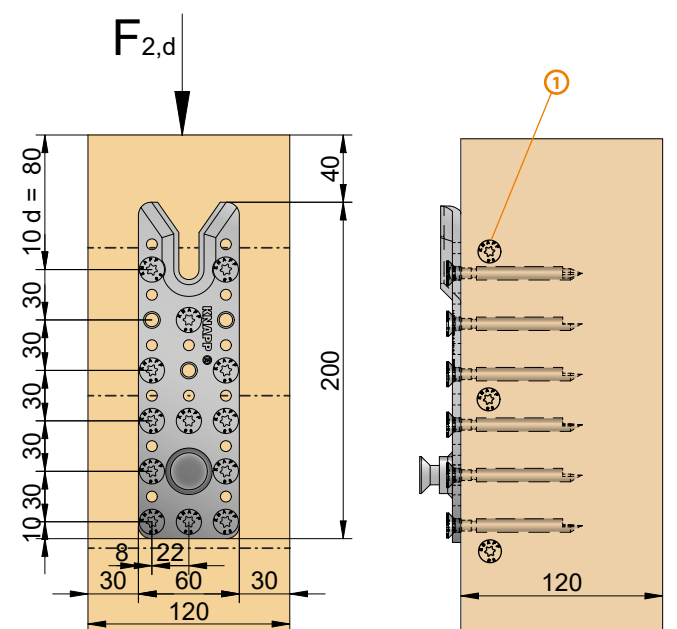
MIN. screw connection
in columnST. screw connection
in column

- ① Arrangement of fully threaded screws for transverse tensile reinforcement. According to the expert opinion (10.09.2021) of Prof. Dr. Blaß, the transverse tensile bolts should have the same screw diameter as the RICON®S screws used. These bolts should have the same length as the column cross-section width.



PRODUCT

RICON®S locking clip

RICON®S 60 locking clip (made of stainless spring steel)

Art.-No.K157

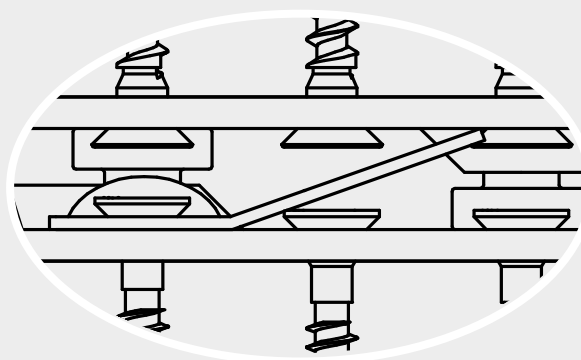
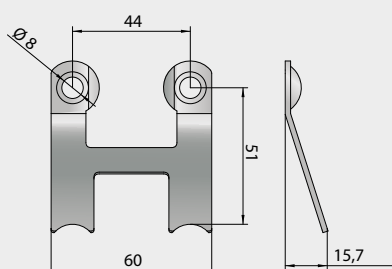

Application: the locking clip locks the connection against slide-in direction and is used for stress against slide-in direction or wind suction.

RICON®S 200/60 VS - Welded collar bolt double post connection

Art.-No.K127

(Dimensions in mm)



Art.-No.	RICON® S	Collar bolt	Screw connection		Charact. values [GL24h] $F_{2,Rk}$ [kN]
			Joist	Column	
K127 ST	2x 200/60	VS	26x CS 8x80	32 x CS 8x160	103.5
Axial tension: $F_{1,Rk} = 63$ kN					
2 clip locks: $F_{3,Rk} = 36$ kN					

ST = standard screw cxn.

All design values are available on our website under the Planner Service tab.

Welded collar bolt

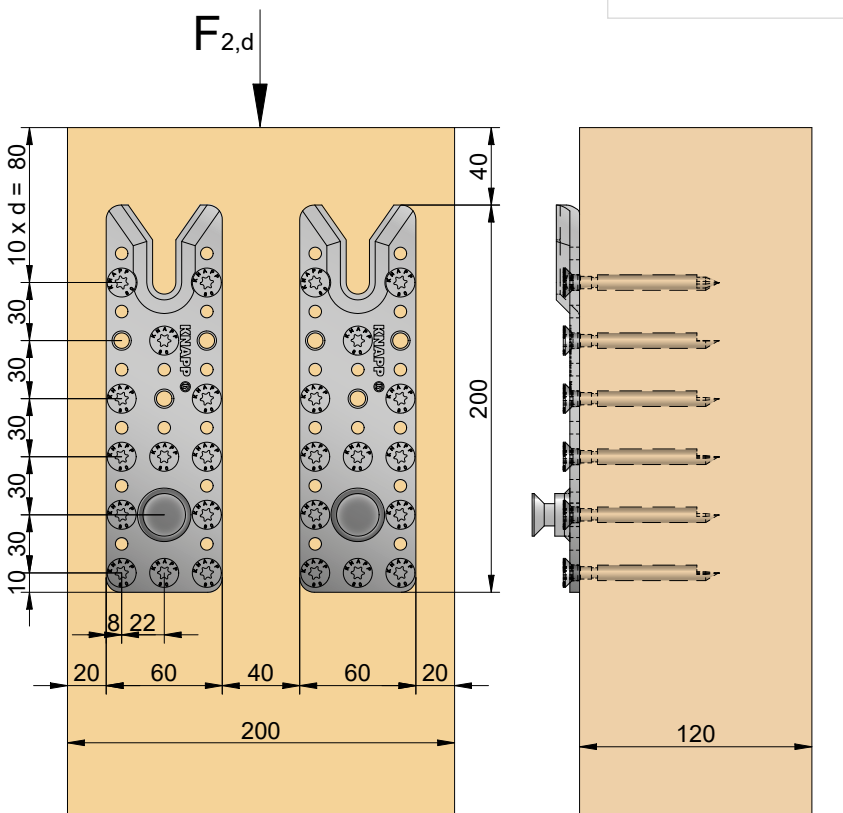
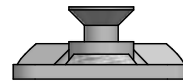

RICON®S locking clip

RICON®S 60 locking clip (made of stainless spring steel)

Art.-No.K157

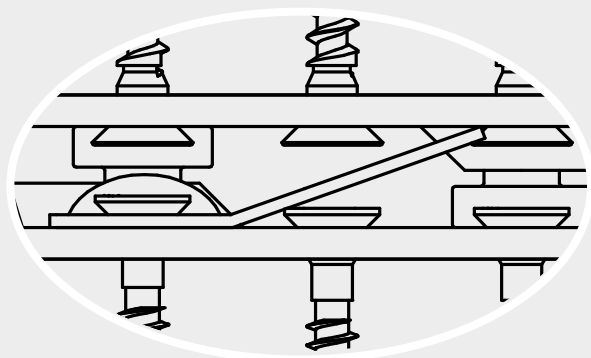
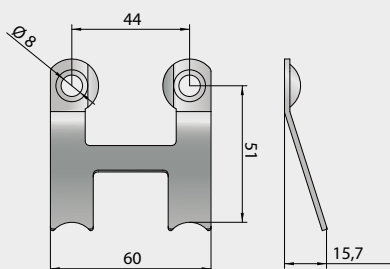

Application: the locking clip locks the connection against slide-in direction and is used for stress against slide-in direction or wind suction.

RICON® S 80 VS

RICON® S 200/80 VS - Welded collar bolt header-joist connection

Art.-No. K128

(Dimensions in mm)

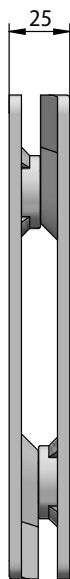
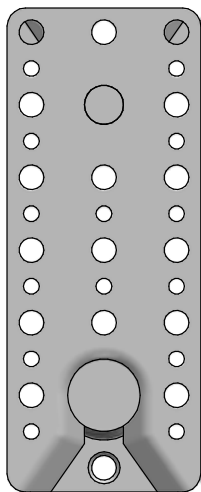

Art.-No.	RICON® S	Collar bolt	Screw connection		Charact. values [GL24h] F _{2,Rk} [kN]
			Joist	Header	
K128 MIN ●	200/80	VS	8 x CS 10x200	8 x CS 10x100	42.3
K128 ST	200/80	VS	16 x CS 10x200	16 x CS 10x100	79.0
K128 MAX	200/80	VS	16 x CS 10x300	16 x CS 10x100	92.4
Axial tension: F _{1,Rk} = 36.0 kN					
Clip lock: F _{3,Rk} = 18.0 kN					

MIN = minimum screw cxn. ST = standard screw cxn. MAX = maximum screw cxn.

Min. timber cross-section: 120 x 230 mm

All design values are available on our website under the Planner Service tab.

Welded collar bolt

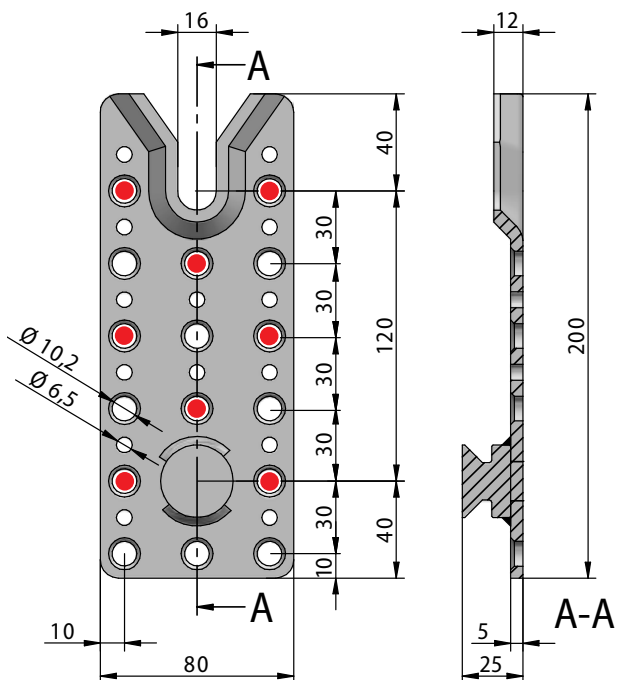
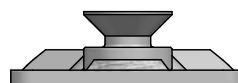

PRODUCT

RICON® S locking clip

RICON® S 80 locking clip (made of stainless spring steel)

Art.-No. K158

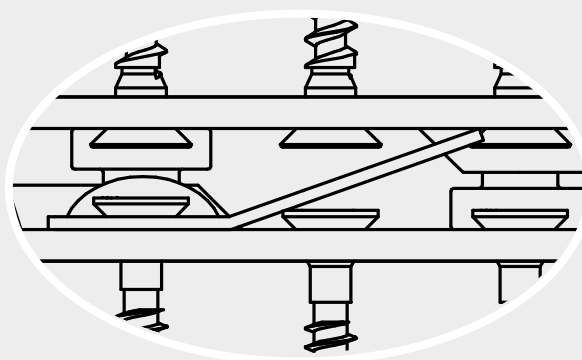
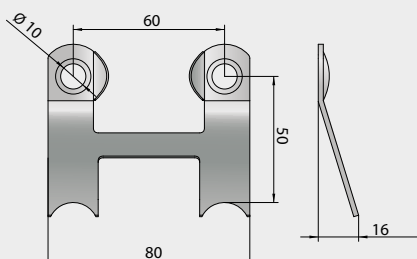

Application: the locking clip locks the connection against slide-in direction and is used for stress against slide-in direction or wind suction.

RICON®S 200/80 VS - Welded collar bolt post connection

Art.-No. K128

(Dimensions in mm)



Art.-No.	RICON® S	Collar bolt	Screw connection		Charact. values [GL24h] $F_{2,Rk}$ [kN]
			Joist	Column	
K128 MIN ●	200/80	VS	9 x CS 10x100	16 x CS 8x160	56.8
K128 ST	200/80	VS	13 x CS 10x100	16 x CS 8x160	68.3
Axial tension: $F_{1,Rk} = 36.0$ kN					
Clip lock: $F_{3,Rk} = 18.0$ kN					

MIN = minimum screw cxn. ST = standard screw cxn.

Min. timber cross-section: MIN = 120 x 120 mm ST = 160 x 160 mm

All design values are available on our website under the Planner Service tab.

Welded collar bolt

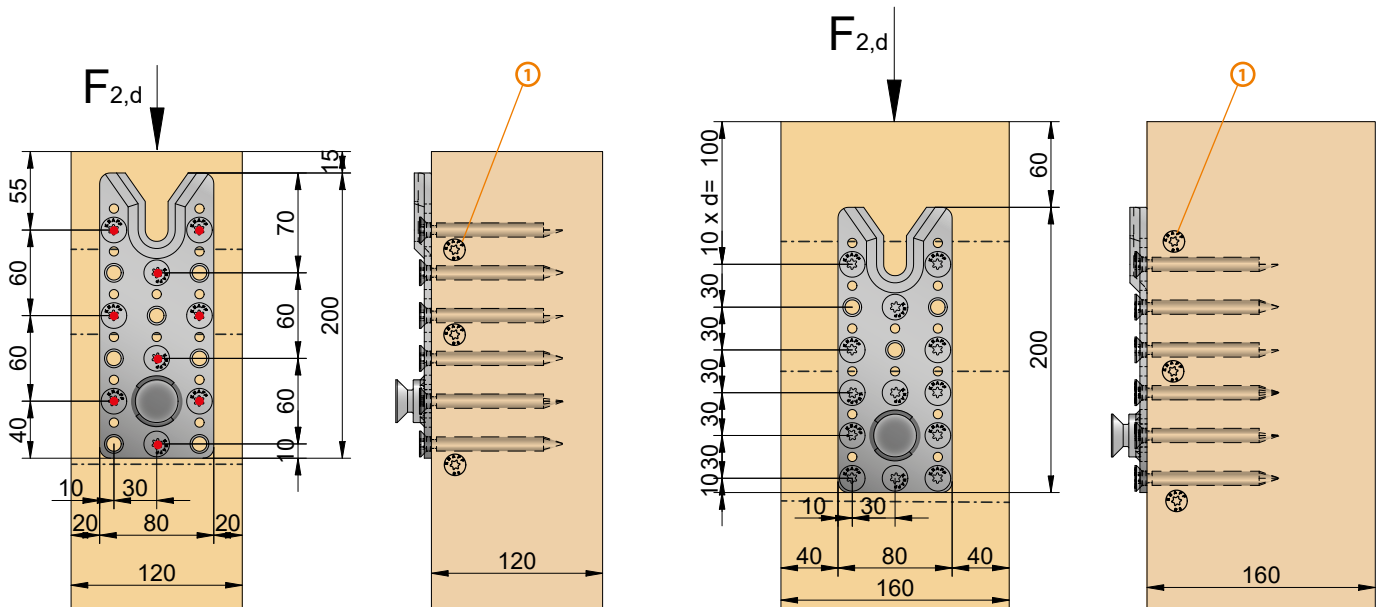
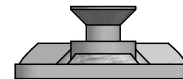

MIN. screw connection in column

ST. screw connection in column

① Arrangement of fully threaded screws for transverse tensile reinforcement. According to the expert opinion (10.09.2021) of Prof. Dr. Blaß, the transverse tensile bolts should have the same screw diameter as the RICON®S screws used. These bolts should have the same length as the column cross-section width.



RICON®S locking clip

RICON®S 80 locking clip (made of stainless spring steel)

Art.-No. K158

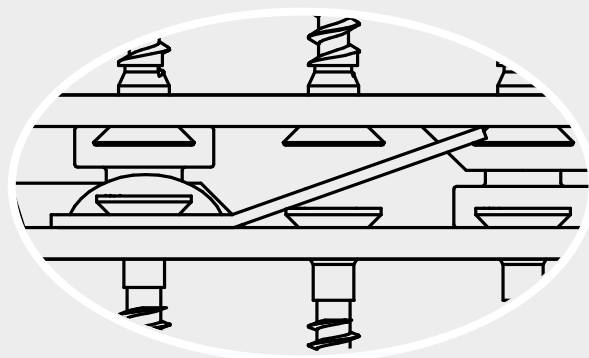
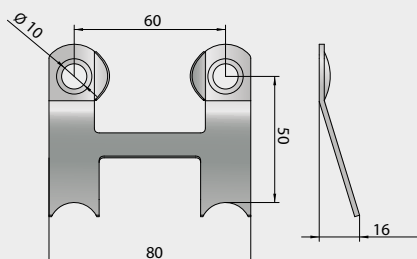

Application: the locking clip locks the connection against slide-in direction and is used for stress against slide-in direction or wind suction.

RICON®S 200/80 VS - Welded collar bolt double post connection

Art.-No. K128

(Dimensions in mm)



Art.-No.	RICON® S	Collar bolt	Screw connection		Charact. values [GL24h] $F_{2,Rk}$ [kN]
			Joist	Column	
K128 ST	2x 200/80	VS	26x CS 10x100	32 x CS 10x160	136.6
Axial tension: $F_{1,Rk} = 63$ kN					
2 clip locks: $F_{3,Rk} = 36$ kN					

ST = standard screw cxn.

Min. timber cross-section: 240x160 mm

All design values are available on our website under the Planner Service tab.

Welded collar bolt

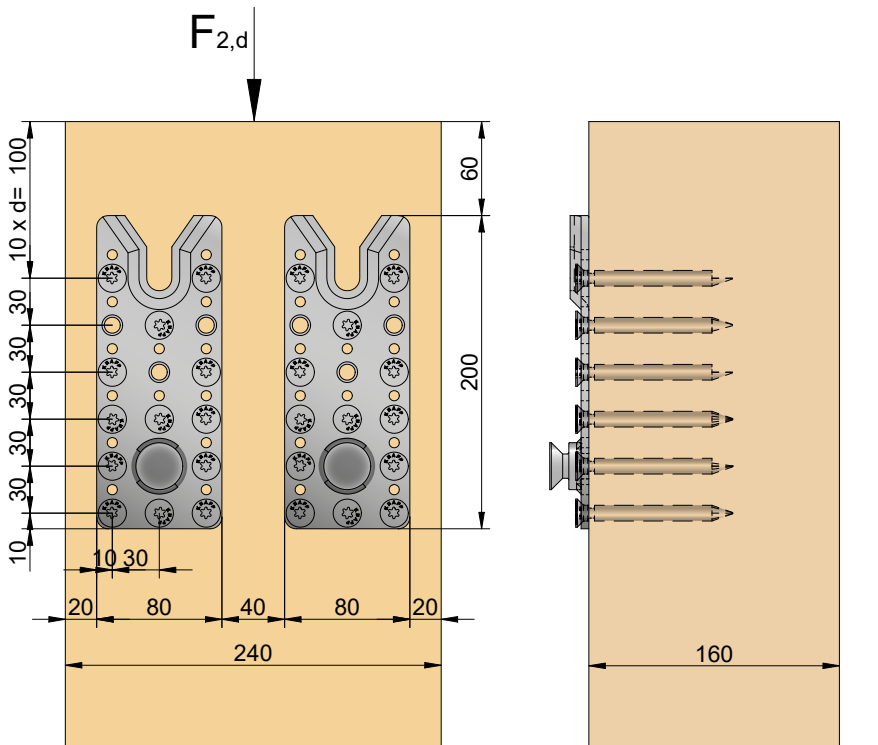
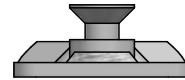

PRODUCT

RICON®S locking clip

RICON®S 80 locking clip (made of stainless spring steel)

Art.-No.K158

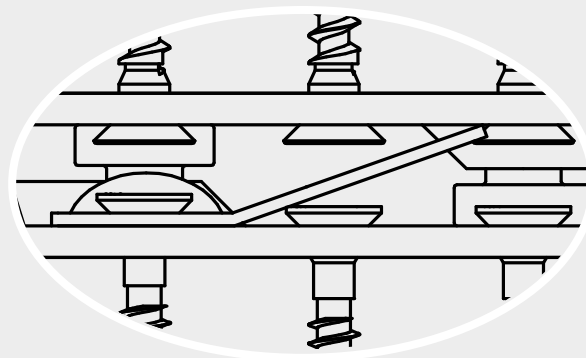
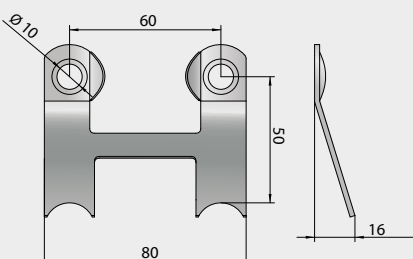

Application: the locking clip locks the connection against slide-in direction and is used for stress against slide-in direction or wind suction.

RICON®S 290/80 VS - Welded collar bolt header-joist connection

Art.-No.K129

(Dimensions in mm)

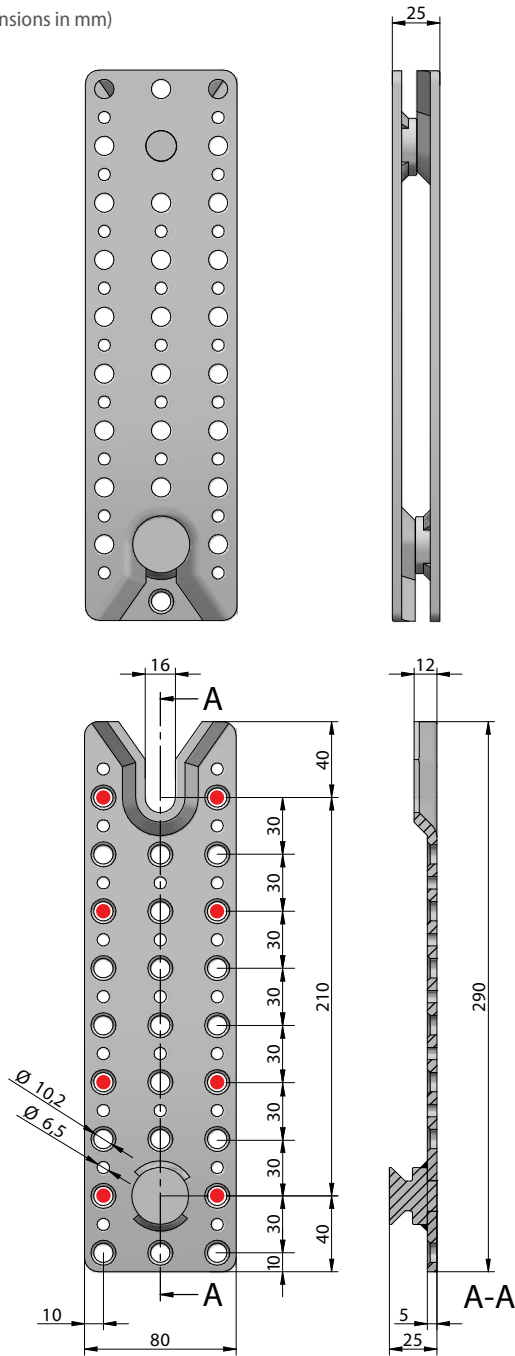

Art.-No.	RICON® S	Collar bolt	Screw connection		Charact. values [GL24h] F _{2,Rk} [kN]
			Joist	Header	
K129 MIN ●	290/80	VS	8 x CS 10x200	8 x CS 10x100	42.3
K129 ST	290/80	VS	25 x CS 10x200	25 x CS 10x100	118.0
K129 MAX	290/80	VS	25 x CS 10x300	25 x CS 10x100	142.7
Axial tension: F _{1,Rk} = 36.0 kN					
Clip lock: F _{3,Rk} = 18.0 kN					

MIN = minimum screw cxn. ST = standard screw cxn. MAX = maximum screw cxn.

Min. timber cross-section: 120 x 320 mm

All design values are available on our website under the Planner Service tab.

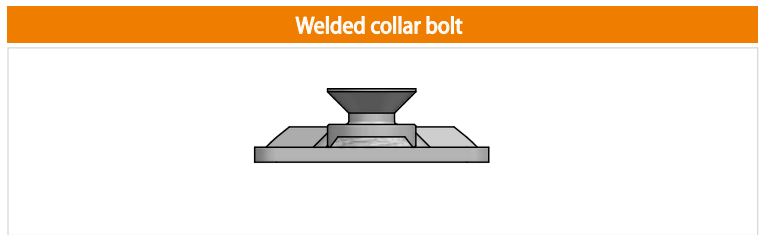

RICON®S locking clip

RICON®S 80 locking clip (made of stainless spring steel)

Art.-No.K158

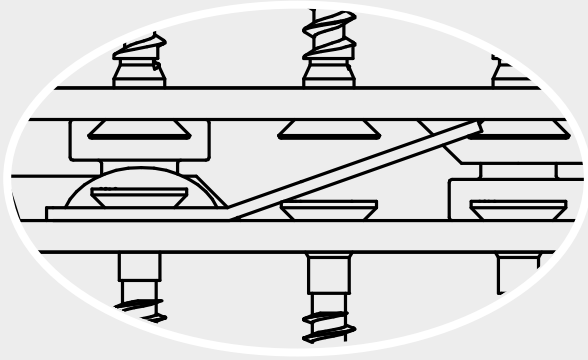
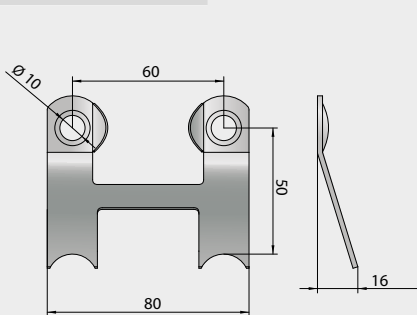

Application: the locking clip locks the connection against slide-in direction and is used for stress against slide-in direction or wind suction.

RICON® S 290/80 VS - Welded collar bolt post connection

Art.-No.K129

(Dimensions in mm)

(Dimensions in mm)



Art.-No.	RICON® S	Collar bolt	Screw connection		Charact. values [GL24h] $F_{2,Rk}$ [kN]
			Joist	Column	
K129 MIN ●	290/80	VS	13 x CS 10x100	25 x CS 10x200	84.4
K129 ST	290/80	VS	20 x CS 10x100	25 x CS 10x200	108.5
Axial tension: $F_{1,Rk} = 36.0$ kN					
Clip lock: $F_{3,Rk} = 18.0$ kN					

MIN = minimum screw cxn. ST = standard screw cxn.

Min. timber cross-section: MIN = 240x160 mm ST = 240x160 mm

All design values are available on our website under the Planner Service tab.

Welded collar bolt

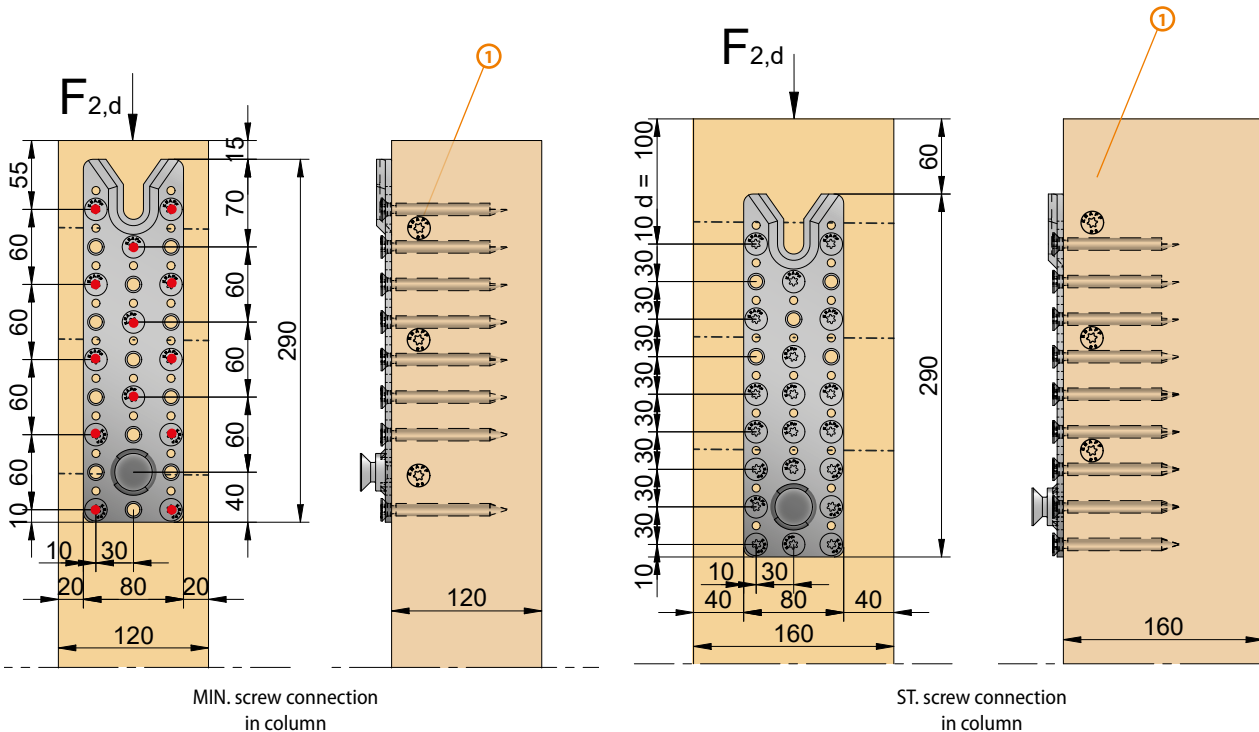
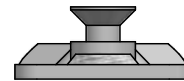

- ① Arrangement of fully threaded screws for transverse tensile reinforcement. According to the expert opinion (10.09.2021) of Prof. Dr. Blaß, the transverse tensile bolts should have the same screw diameter as the RICON®S screws used. These bolts should have the same length as the column cross-section width.



PRODUCT

RICON®S locking clip

RICON®S 80 locking clip (made of stainless spring steel)

Art.-No.K158

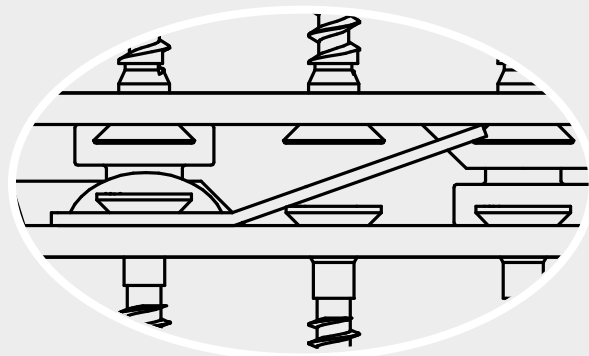
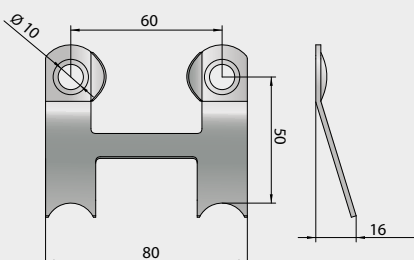

Application: the locking clip locks the connection against slide-in direction and is used for stress against slide-in direction or wind suction.

RICON®S 290/80 VS - Welded collar bolt double post connection

Art.-No.K129



$F_{2,d}$

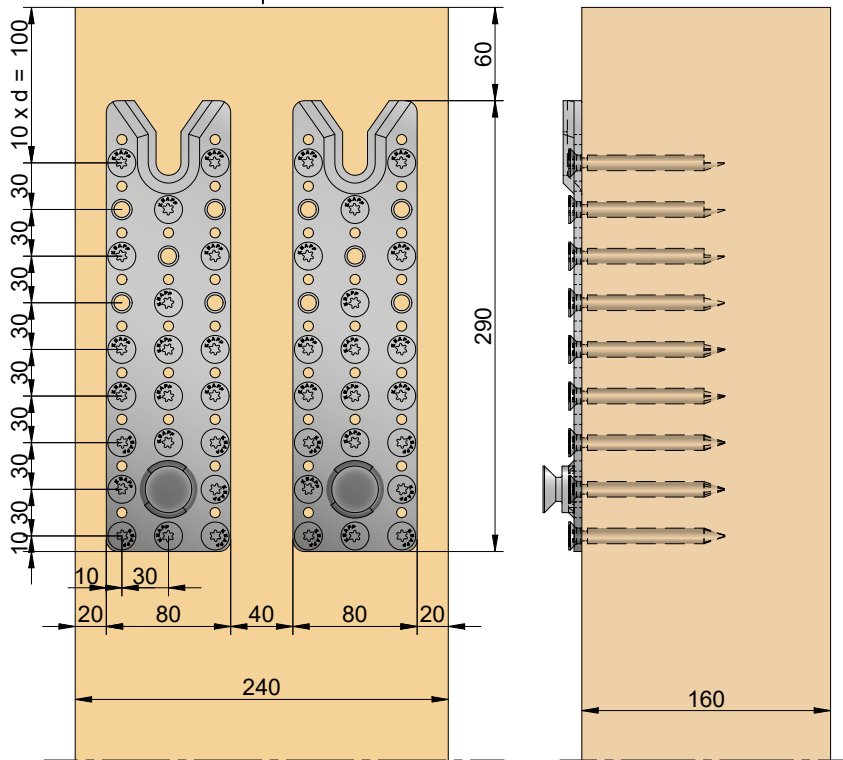

Art.-No.	RICON® S	Collar bolt	Screw connection		Charact. values [GL24h] $F_{2,Rk}$ [kN]
			Joist	Column	
K129 ST	2x 290/80	VS	40 x CS 10x100	240x160	216.9
Axial tension: $F_{1,Rk} = 63$ kN					
2 clip locks: $F_{3,Rk} = 36$ kN					

ST = standard screw cxn.

Min. timber cross-section: ST = 240x160 mm

All design values are available on our website under the Planner Service tab.

Welded collar bolt



PRODUCT

RICON®S locking clip

RICON®S 80 locking clip (made of stainless spring steel)

Art.-No.K158

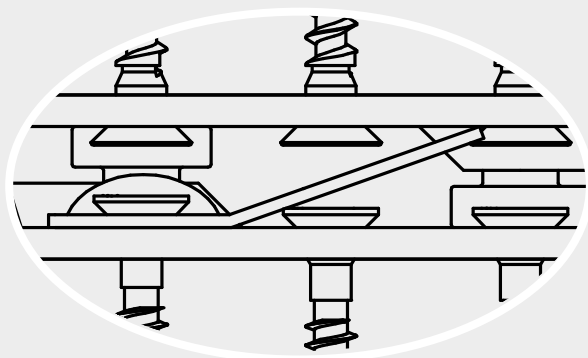
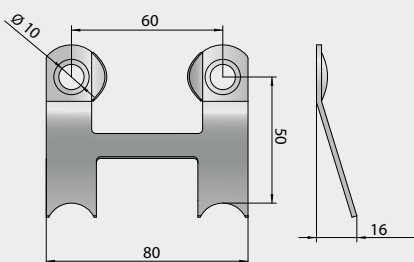

Application: the locking clip locks the connection against slide-in direction and is used for stress against slide-in direction or wind suction.

RICON® S 390/80 VS ZP - header-joint 30° screw connection

Art.-No.K191

(Dimensions in mm)

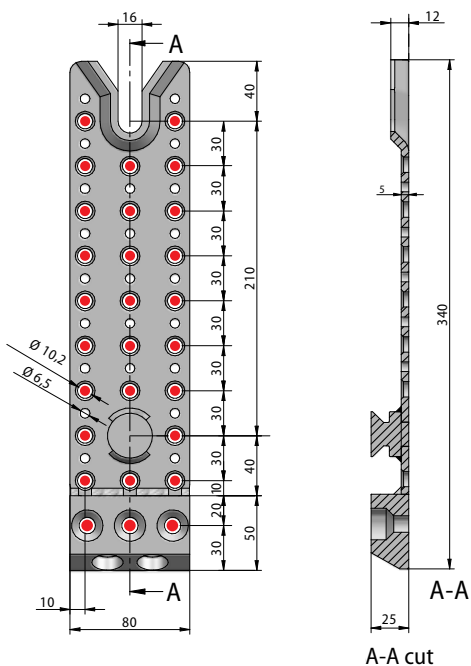
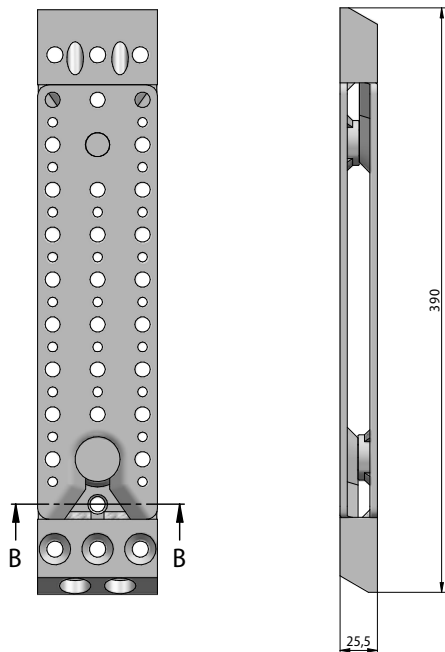

Art.-No.	RICON® S	Collar bolt	Screw connection		Charact. values [GL24h] $F_{2,Rk}$ [kN]
			Joist	Header	
K191 MIN ●	390/80	VS	28 x CS 10x200	28 x CS 10x100	130.6
K191 ST	390/80	VS	28 x CS 10x200 2 x CS 10x450	28 x CS 10x100 2 x CS 10x400	170.6
K191 MAX	390/80	VS	28 x CS 10x300 2 x CS 10x450	28 x CS 10x100 2 x CS 10x400	195.3
Axial tension: $F_{1,Rk} = 36.0$ kN					
Clip lock: $F_{3,Rk} = 18.0$ kN					

MIN = minimum screw cxn. ST = standard screw cxn. MAX = maximum screw cxn.

Min. timber cross-section: 120 x 720 mm ou 160 x 520 mm

All design values are available on our website under the Planner Service tab.

Welded collar bolt

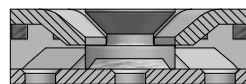

B-B cut

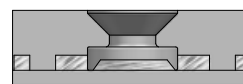

View with additional plate



PRODUCT

RICON® S locking clip

RICON® S 80 locking clip (made of stainless spring steel)

Art.-No.K158

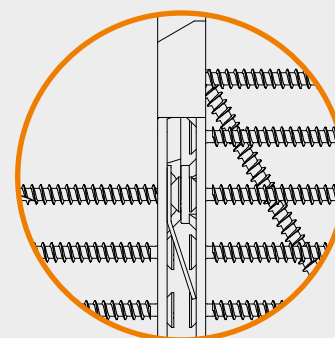
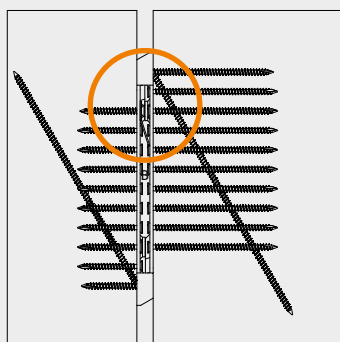
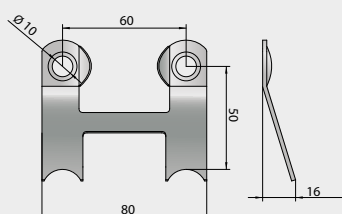

Application: the locking clip locks the connection against slide-in direction and is used for stress against slide-in direction or wind suction.

RICON®S390/80 VS - post 30° screw connection

Art.-No.K191

(Dimensions in mm)



Art.-No.	RICON® S	Collar bolt	Screw connection		Charact. values [GL24h] F _{2,Rk} [kN]
			Joist	Column	
K191 MIN ●	390/80	VS	23 x CS 10x100	28 x CS 10x200 2 x CS 10x450	124.8
K191 ST	390/80	VS	23 x CS 10x100 2 x CS 10x400	28 x CS 10x200 2 x CS 10x450	164.8
Axial tension: F _{1,Rk} = 36.0 kN					
Clip lock: F _{3,Rk} = 18.0 kN					

MIN = minimum screw cxn. ST = standard screw cxn.
Min. timber cross-section: 160 x 160 mm ou 160 x 200 mm
All design values are available on our website under the Planner Service tab.

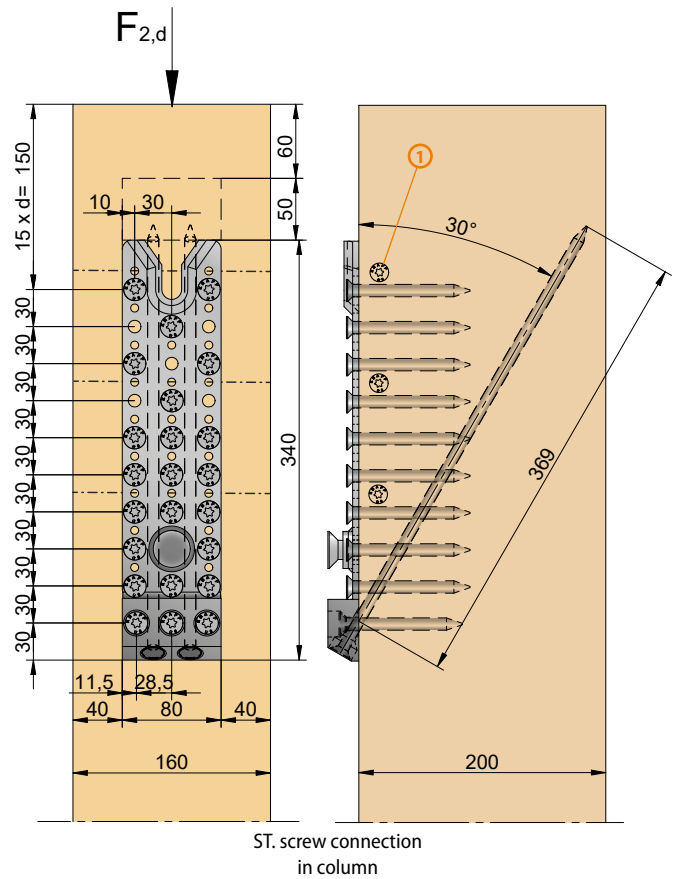
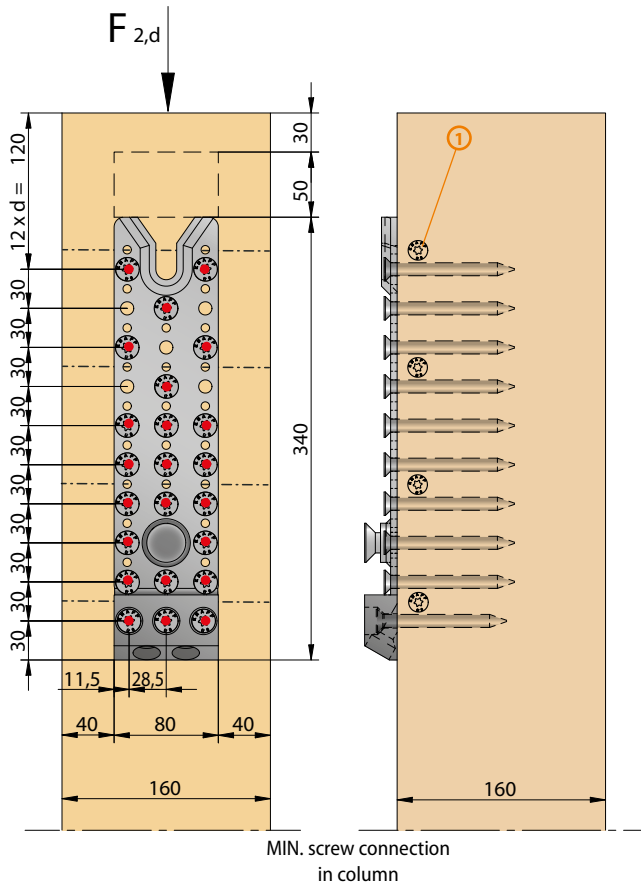
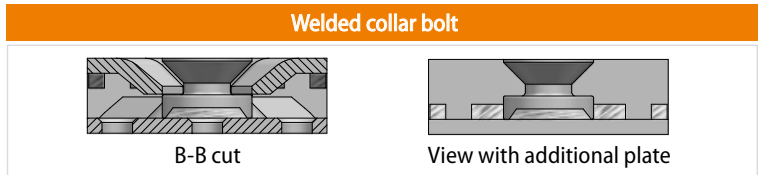

① Arrangement of fully threaded screws for transverse tensile reinforcement. According to the expert opinion (10.09.2021) of Prof. Dr. Blaß, the transverse tensile bolts should have the same screw diameter as the RICON®S screws used. These bolts should have the same length as the column cross-section width.

RICON®S locking clip

RICON®S 80 locking clip (made of stainless spring steel)

Art.-No.K158

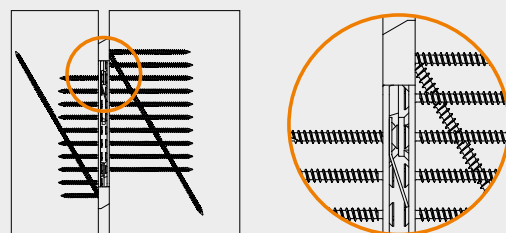
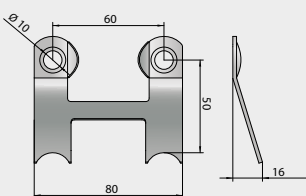

Application: the locking clip locks the connection against slide-in direction and is used for stress against slide-in direction or wind suction.

RICON® S 390/80 VS ZP - post 30° screw double connection

Art.-No.K191

(Dimensions in mm)



Art.-No.	RICON® S	Collar bolt	Screw connection		Charact. values [GL24h] $F_{2,Rk}$ [kN]
			Joist	Column	
K191 MIN ●	390/80	VS	46 x CS 10x100	56 x CS 10x200 4 x CS 10x450	249.8
K191 ST	390/80	VS	46 x CS 10x100 46 x CS 10x400	58 x CS 10x200 4 x CS 10x450	164.8

Axial tension: $F_{1,Rk} = 36.0$ kN
Clip lock: $F_{3,Rk} = 18.0$ kN

MIN = minimum screw cxn. ST = standard screw cxn.

Min. timber cross-section: 240 x 160 mm ou 240 x 200 mm

All design values are available on our website under the Planner Service tab.

Welded collar bolt

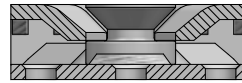

B-B cut

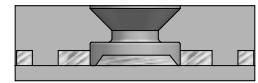

View with additional plate

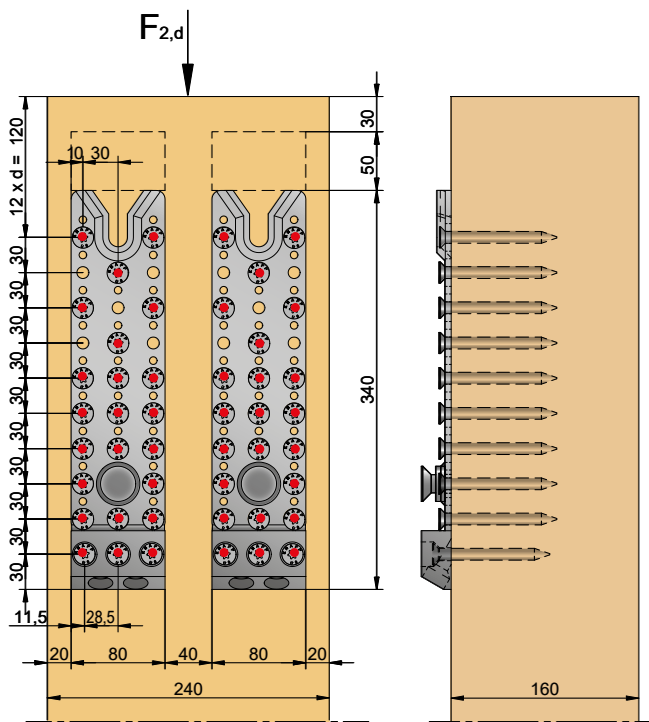
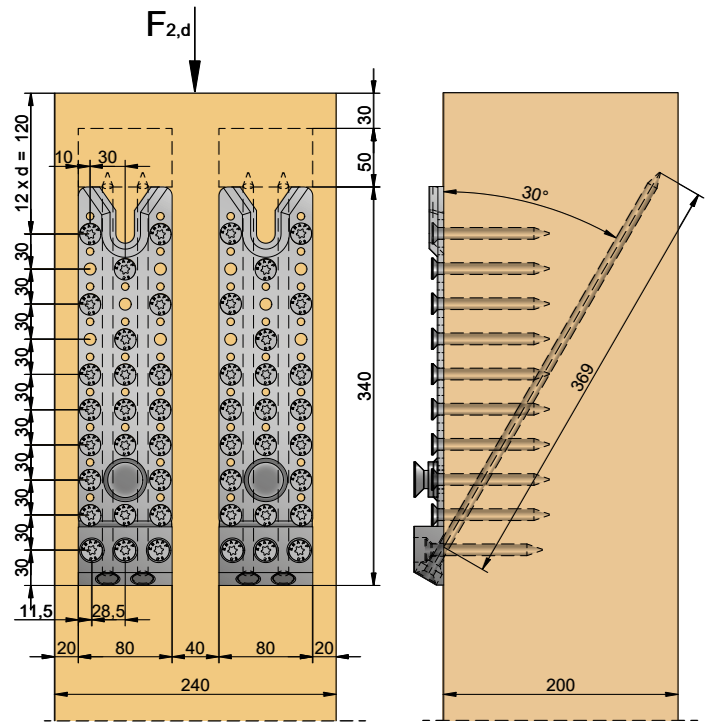
MIN. screw connection
in columnST. screw connection
in column

RICON® S locking clip

RICON® S 80 locking clip (made of stainless spring steel)

Art.-No.K158

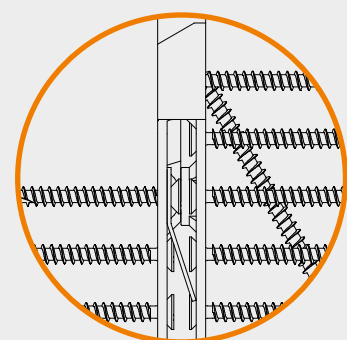
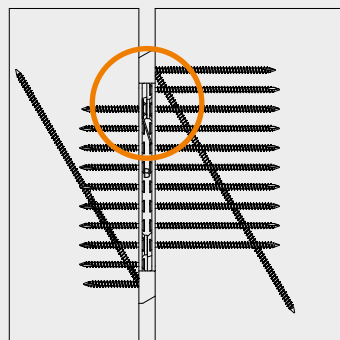
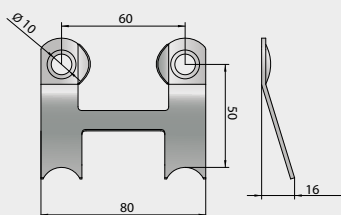

Application: the locking clip locks the connection against slide-in direction and is used for stress against slide-in direction or wind suction.

RICON®S 60 EK

RICON®S 140/60 EK - Adjustable collar bolt

Art.-No.K146

(Dimensions in mm)

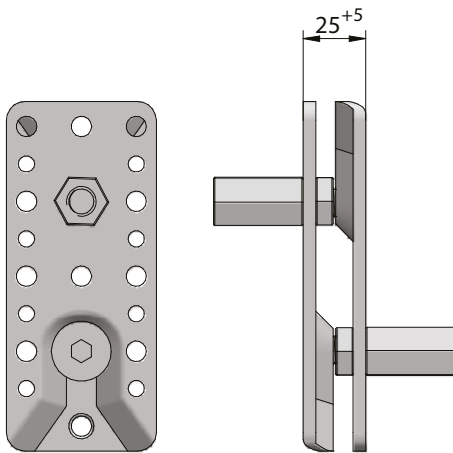

Art.-No.	RICON® S	Collar bolt	Screw connection		Charact. values [GL24h] F _{2,Rk} [kN]
			Joist	Header	
K146 MIN ●	140/60	EK M12	7 x CS 8x160	7 x CS 8x80	26.9
K146 ST	140/60	EK M12	10 x CS 8x160	10 x CS 8x80	37.1
K146 MAX	140/60	EK M12	10 x CS 8x240	10 x CS 8x80	40.2
Axial tension: F _{1,Rk} = 31.5 kN					
Clip lock: F _{3,Rk} = 18.0 kN					

MIN = minimum screw cxn. ST = standard screw cxn. MAX = maximum screw cxn.
 Min. timber cross-section: 100 x 160 mm
 All design values are available on our website under the Planner Service tab.

Adjustable collar bolt, for tolerance adjustment

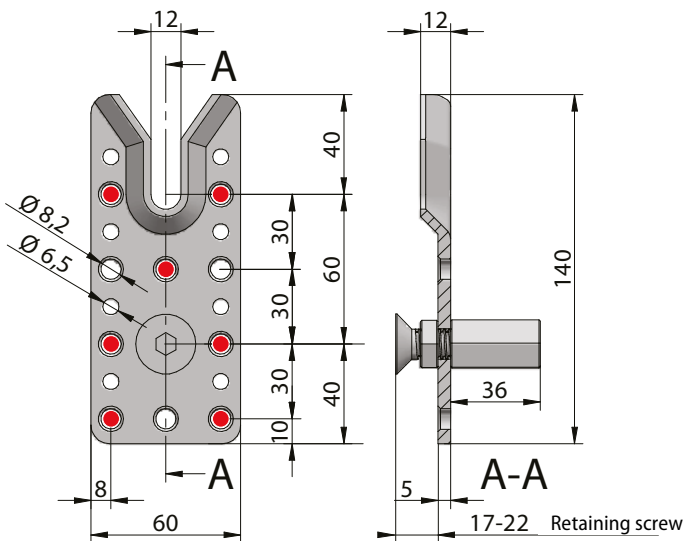
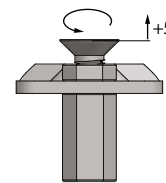

RICON®S locking clip

RICON®S locking clip 60 (made of stainless spring steel)

Art.-No.K157

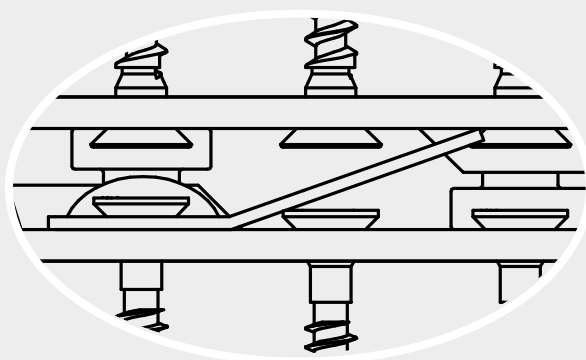
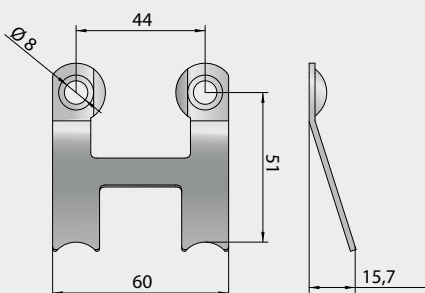

Application: the locking clip locks the connection against slide-in direction and is used for stress against slide-in direction or wind suction.

RICON® S 200/60 EK - Adjustable collar bolt

Art.-No.K148

(Dimensions in mm)

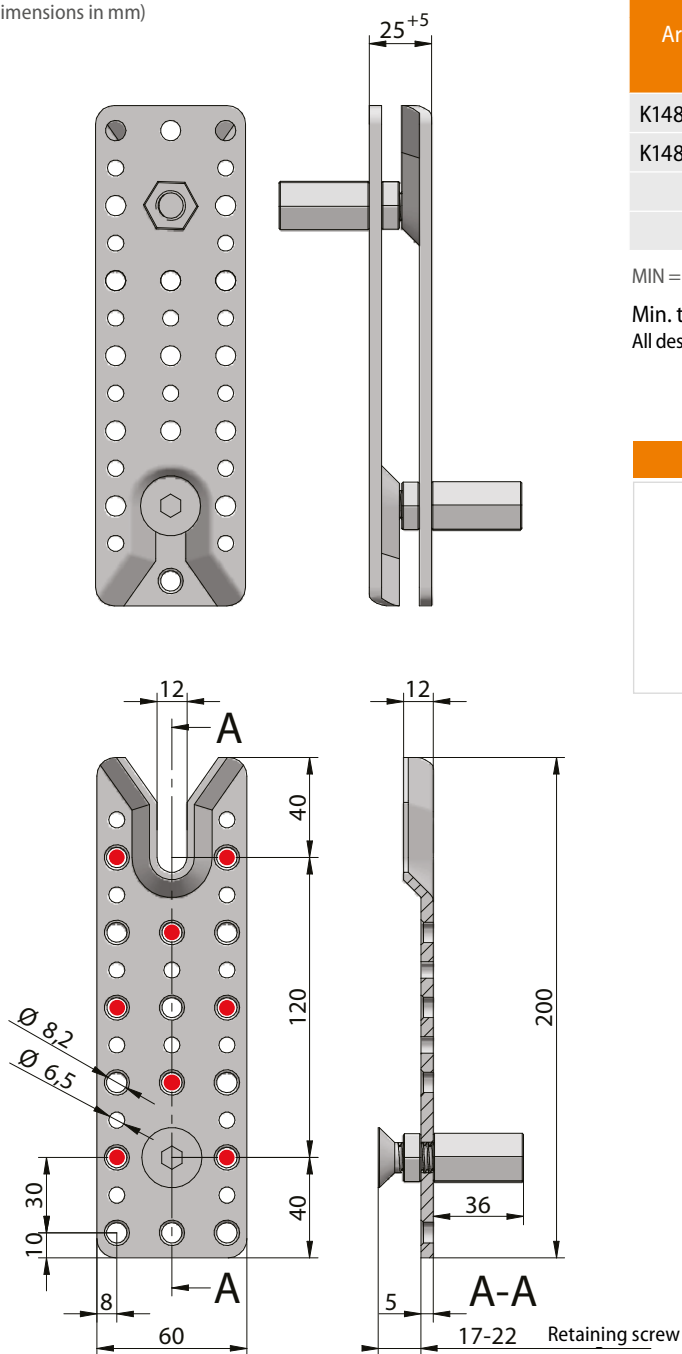

Art.-No.	RICON® S	Collar bolt	Screw connection		Charact. values [GL24h] $F_{2,Rk}$ [kN]
			Joist	Header	
K148 MIN ●	200/60	EK M12	8 x CS 8x160	8 x CS 8x80	30.4
K148 ST	200/60	EK M12	16 x CS 8x160	16 x CS 8x80	44.2
Axial tension: $F_{1,Rk} = 31.5$ kN					
Clip lock: $F_{3,Rk} = 18.0$ kN					

MIN = minimum screw cxn. ST = standard screw cxn.

Min. timber cross-section: 100 x 220 mm

All design values are available on our website under the Planner Service tab.

Adjustable collar bolt, for tolerance adjustment

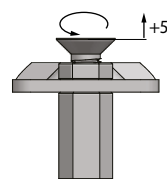

PRODUCT

RICON® S locking clip

RICON® S locking clip 60 (made of stainless spring steel)

Art.-No.K157

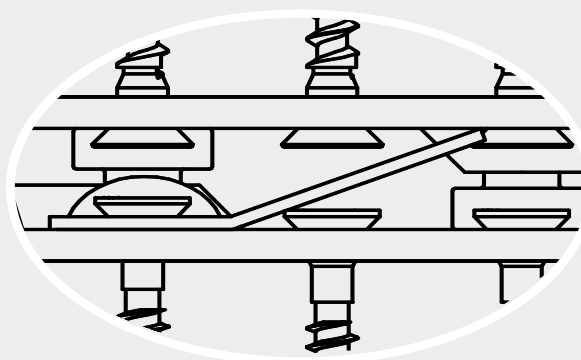
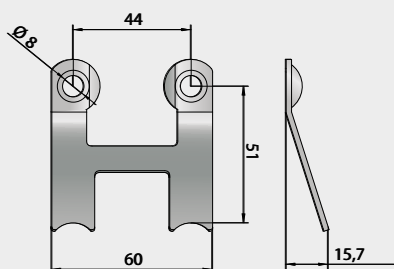

Application: the locking clip locks the connection against slide-in direction and is used for stress against slide-in direction or wind suction.

RICON® S 80 EK

RICON®S 200/80 EK - Adjustable collar bolt

Art.-No.K153

(Dimensions in mm)

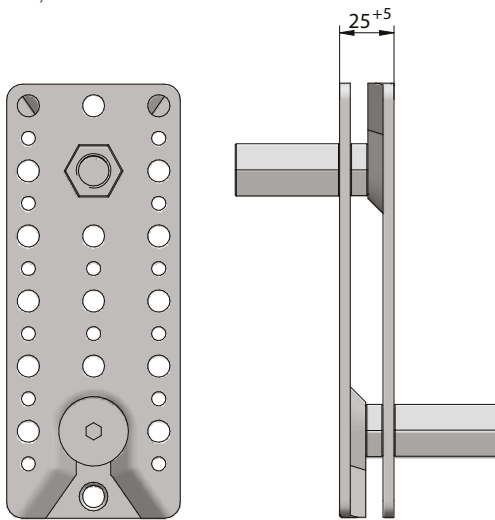

Art.-No.	RICON® S	Collar bolt	Screw connection		Charact. values [GL24h] F _{2,Rk} [kN]
			Joist	Header	
K153 MIN ●	200/80	EK M16	8 x CS 10x200	8 x CS 10x100	42.4
K153 ST	200/80	EK M16	16 x CS 10x200	16 x CS 10x100	65.0
Axial tension: F _{1,Rk} = 36.0 kN					
Clip lock: F _{3,Rk} = 18.0 kN					

MIN = minimum screw cxn. ST = standard screw cxn.

Min. timber cross-section: 120 x 230 mm

All design values are available on our website under the Planner Service tab.

Adjustable collar bolt, for tolerance adjustment

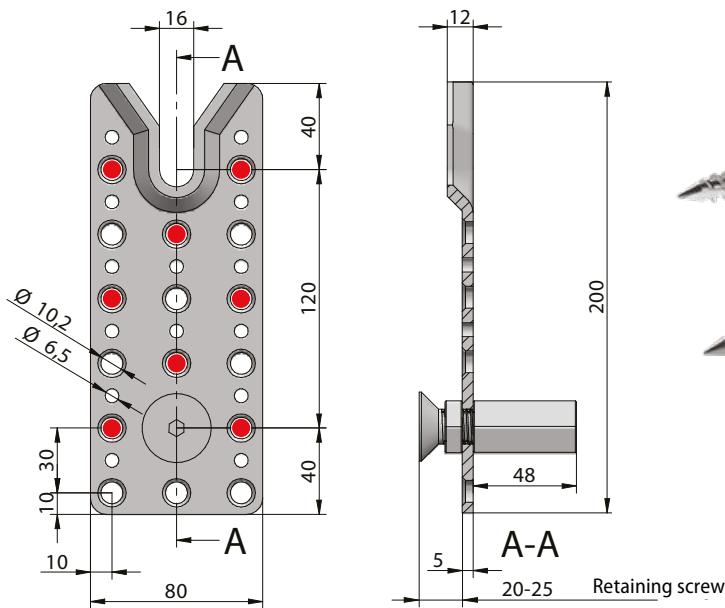
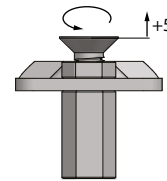

RICON®S locking clip

RICON®S locking clip 80 (made of stainless spring steel)

Art.-No.K158

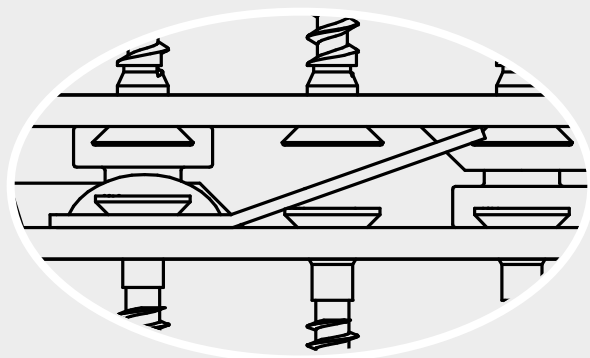
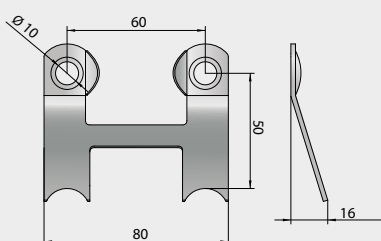

Application: the locking clip locks the connection against slide-in direction and is used for stress against slide-in direction or wind suction.

RICON® S 290/80 EK - Adjustable collar bolt

Art.-No.K156

(Dimensions in mm)

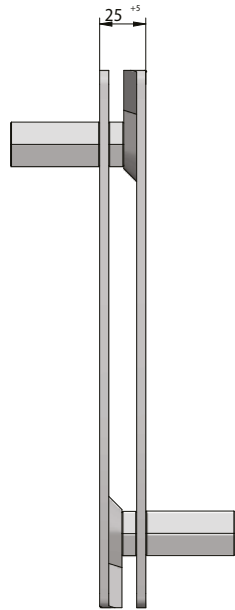
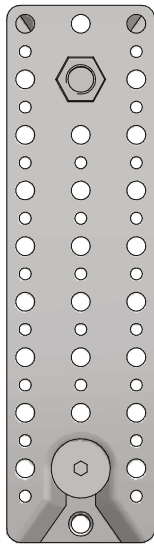

Art.-No.	RICON® S	Collar bolt	Screw connection		Charact. values [GL24h] $F_{2,Rk}$ [kN]
			Joist	Header	
K156 MIN ●	290/80	EK M16	8 x CS 10x200	8 x CS 10x100	42,4
K156 ST	290/80	EK M16	20 x CS 10x200	20 x CS 10x100	72.2
Axial tension: $F_{1,Rk} = 36.0$ kN					
Clip lock: $F_{3,Rk} = 18.0$ kN					

MIN = minimum screw cxn. ST = standard screw cxn.

Min. timber cross-section: 120 x 320 mm

All design values are available on our website under the Planner Service tab.

Adjustable collar bolt, for tolerance adjustment

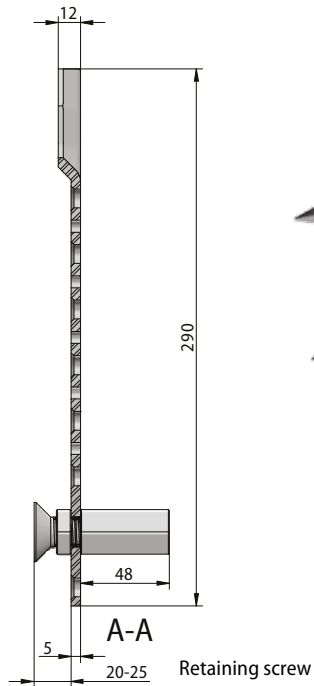
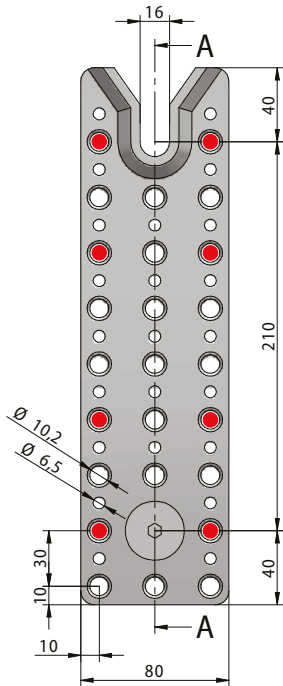
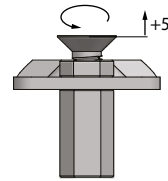

PRODUCT

RICON® S locking clip

RICON® S locking clip 80 (made of stainless spring steel)

Art.-No.K158

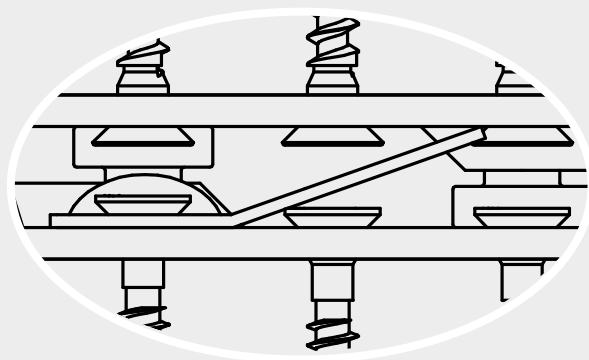
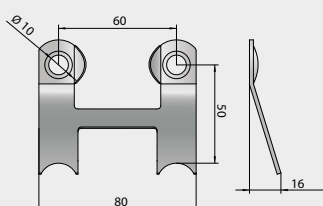

Application: the locking clip locks the connection against slide-in direction and is used for stress against slide-in direction or wind suction.

RICON® S 60 EK

RICON® S 140/60 EK M12 - Adjustable collar bolt and insert screw

Art.-No.K280

(Dimensions in mm)

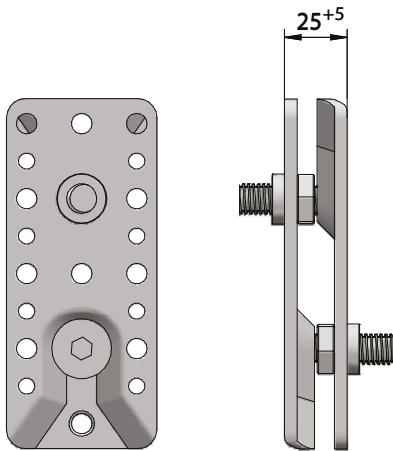

Art.-No.	RICON® S	Collar bolt	Screw connection		Charact. values [GL24h] F _{2,Rk} [kN]
			Joist	Header	
K280 MIN ●	140/60	EK M12	7 x CS 8x160	7 x CS 8x80	26.9
K280 ST	140/60	EK M12	10 x CS 8x160	10 x CS 8x80	37.1
K280 MAX	140/60	EK M12	10 x CS 8x240	10 x CS 8x80	40.2
Axial tension: F _{1,Rk} = 31.5 kN					
Clip lock: F _{3,Rk} = 18.0 kN					

MIN = minimum screw cxn. ST = standard screw cxn. MAX = maximum screw cxn.

Min. timber cross-section: 100 x 160 mm

All design values are available on our website under the Planner Service tab.

Adjustable collar bolt, and insert screw

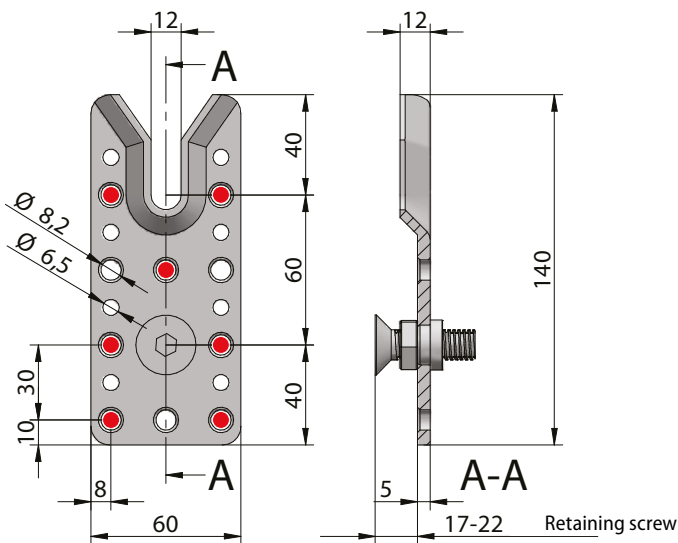
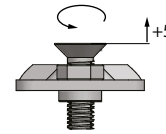

RICON® S locking clip

RICON® S locking clip 60 (made of stainless spring steel)

Art.-No.K157

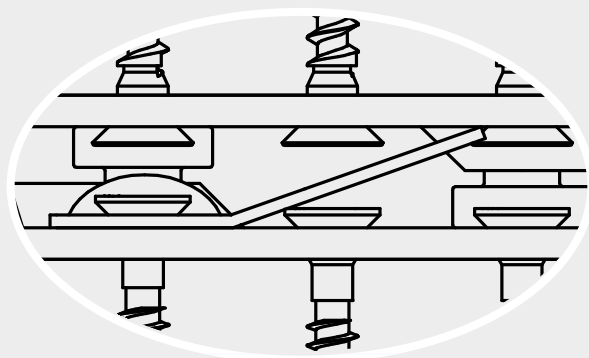
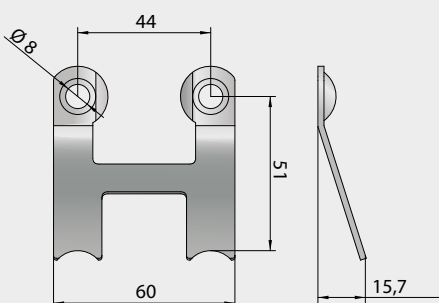

Application: the locking clip locks the connection against slide-in direction and is used for stress against slide-in direction or wind suction.

RICON® S 200/60 EK M12 - Adjustable collar bolt and insert screw

Art.-No.K281

(Dimensions in mm)

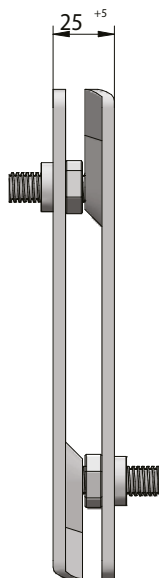
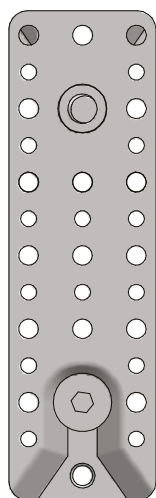

Art.-No.	RICON® S	Collar bolt	Screw connection		Charact. values [GL24h] $F_{2,Rk}$ [kN]
			Joist	Header	
K281 MIN ●	200/60	EK M12	8 x CS 8x160	8 x CS 8x80	30.4
K281 ST	200/60	EK M12	16 x CS 8x160	16 x CS 8x80	44.2
Axial tension: $F_{1,Rk} = 31.5$ kN					
Clip lock: $F_{3,Rk} = 18.0$ kN					

MIN = minimum screw cxn. ST = standard screw cxn.

Min. timber cross-section: 100 x 220 mm

All design values are available on our website under the Planner Service tab.

Adjustable collar bolt and insert screw

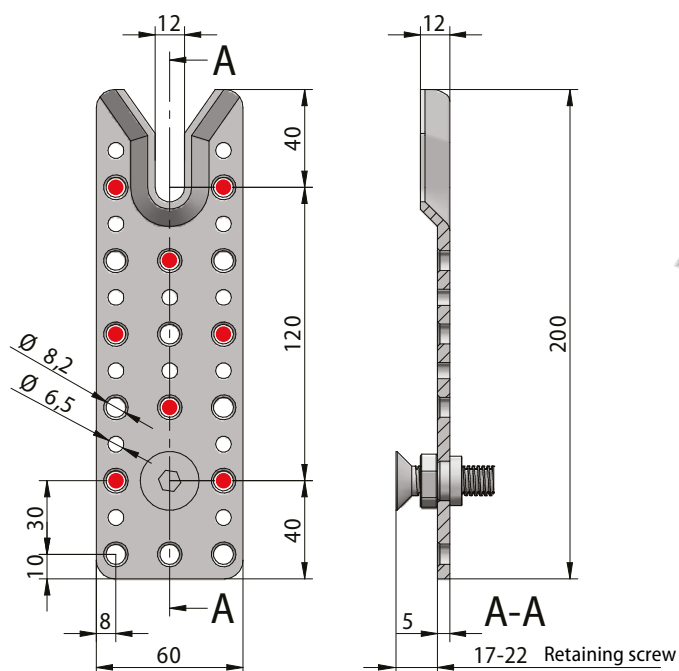
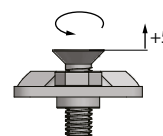

PRODUCT

RICON® S locking clip

RICON® S locking clip 60 (made of stainless spring steel)

Art.-No.K157

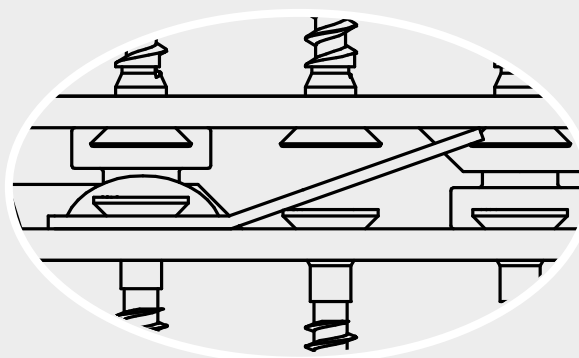
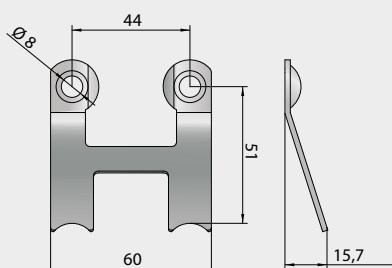

Application: the locking clip locks the connection against slide-in direction and is used for stress against slide-in direction or wind suction.

RICON® S 80 EK

RICON® S 200/80 EK M16 - Adjustable collar bolt and insert screw

Art.-No.K282

(Dimensions in mm)

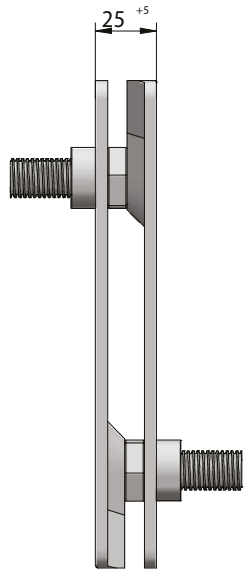
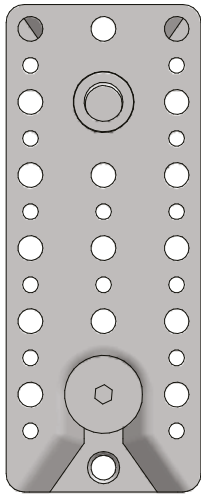

Art.-No.	RICON® S	Collar bolt	Screw connection		Charact. values [GL24h] F _{2,Rk} [kN]
			Joist	Header	
K282 MIN ●	200/80	EK M16	8 x CS 10x200	8 x CS 10x100	42.4
K282 ST	200/80	EK M16	16 x CS 10x200	16 x CS 10x100	65.0
Axial tension: F _{1,Rk} = 36,0 kN					
Clip lock: F _{3,Rk} = 18.0 kN					

MIN = minimum screw cxn. ST = standard screw cxn.

Min. timber cross-section: 120 x 230 mm

All design values are available on our website under the Planner Service tab.

Adjustable collar bolt and insert screw

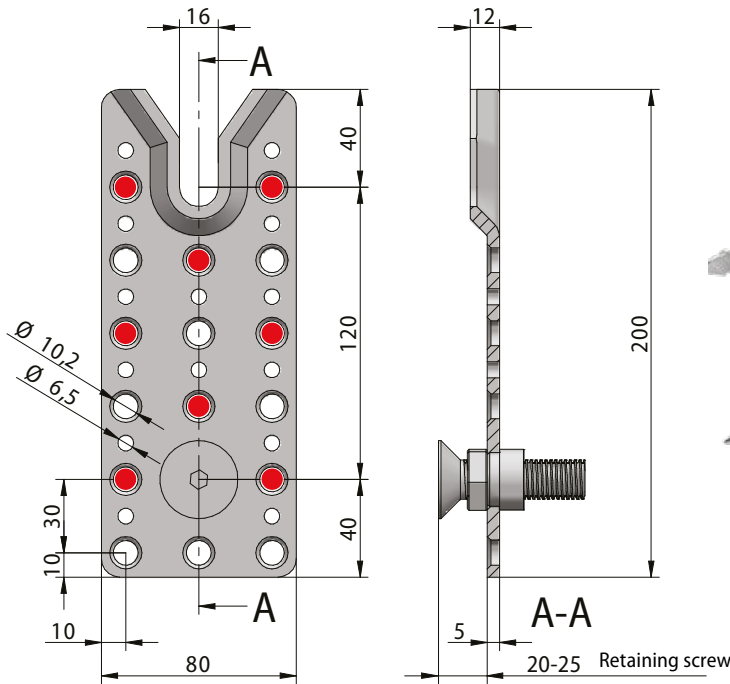
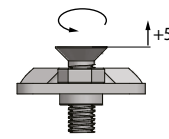

RICON® S locking clip

RICON® S locking clip 80 (made of stainless spring steel)

Art.-No.K158

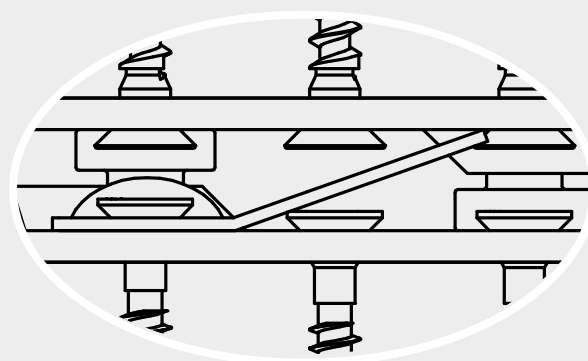
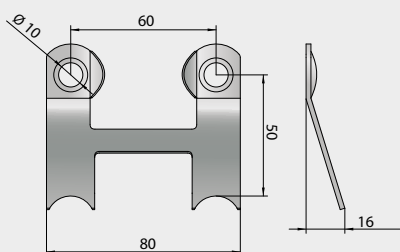

Application: the locking clip locks the connection against slide-in direction and is used for stress against slide-in direction or wind suction.

RICON® S 290/80 EK M16 - Adjustable collar bolt and insert screw (available upon request)

Art.-No.K283

(Dimensions in mm)

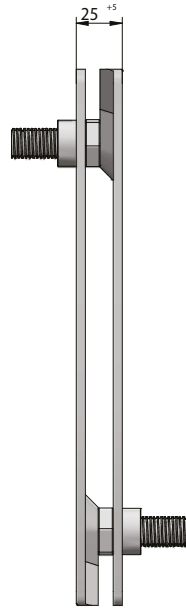
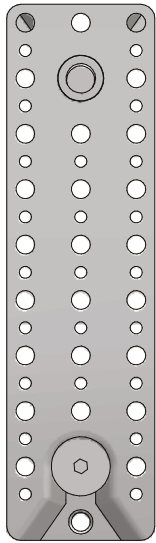

Art.-No.	RICON® S	Collar bolt	Screw connection		Charact. values [GL24h] F _{2,Rk} [kN]
			Joist	Header	
K283 MIN ●	290/80	EK M16	8 x CS 10x200	8 x CS 10x100	42.4
K283 ST	290/80	EK M16	20 x CS 10x200	20 x CS 10x100	72.2
Axial tension: F _{1,Rk} = 36.0 kN					
Clip lock: F _{3,Rk} = 18.0 kN					

MIN = minimum screw cxn. ST = standard screw cxn.

Min. timber cross-section: 120 x 320 mm

All design values are available on our website under the Planner Service tab.

Adjustable collar bolt, for tolerance adjustment

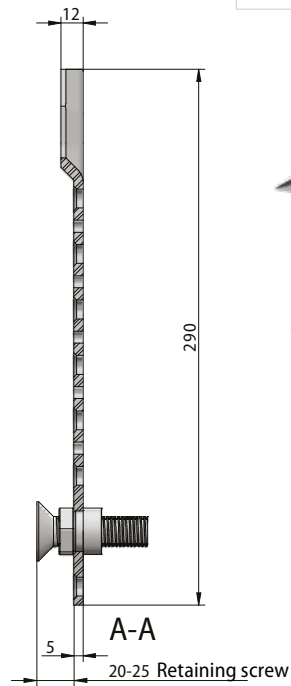
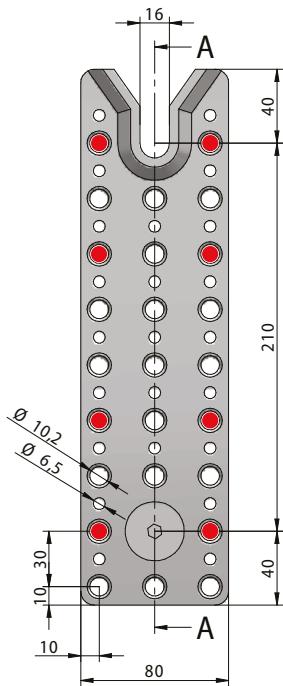
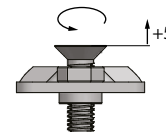

PRODUCT

RICON® S locking clip

RICON® S locking clip 80 (made of stainless spring steel)

Art.-No.K158

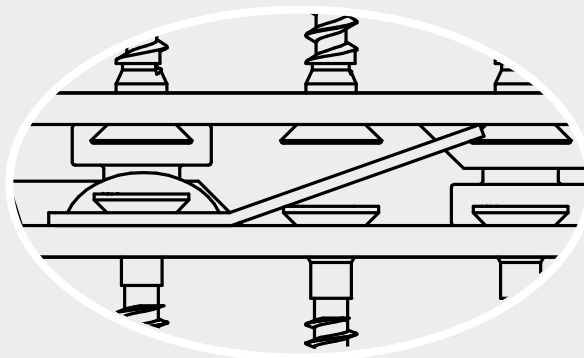
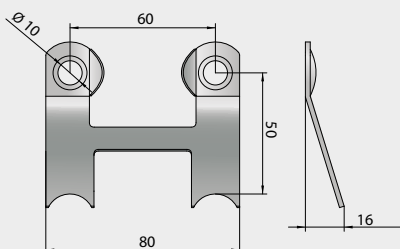

Application: the locking clip locks the connection against slide-in direction and is used for stress against slide-in direction or wind suction.

RICON®S 60 VK

RICON®S 140/60 VK - Screwed collar bolt

Art.-No.K130

(Dimensions in mm)

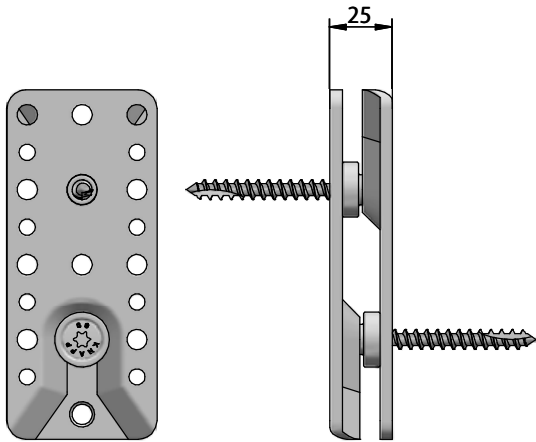

Art.-No.	RICON® S	Collar bolt	Screw connection		Charact. values [GL24h] F _{2,Rk} [kN]
			Joist	Header	
K130 ST	140/60	VK D12	8 x CS 8x160	8 x CS 8x80	31.5
K130 MAX	140/60	VK D12	8 x CS 8x240	8 x CS 8x80	33.5
Axial tension: F _{1,Rk} = 13.0 kN					
Clip lock: F _{3,Rk} = 18.0 kN					

MIN = minimum screw cxn. ST = standard screw cxn.

Min. timber cross-section: 100 x 160 mm

All design values are available on our website under the Planner Service tab.

Screwed collar bolt

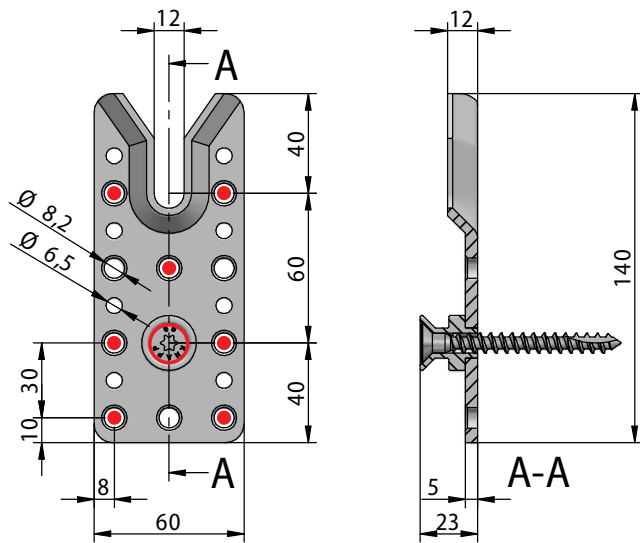
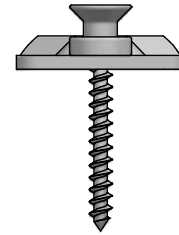

RICON®S locking clip

RICON®S locking clip 60 (made of stainless spring steel)

Art.-No.K157

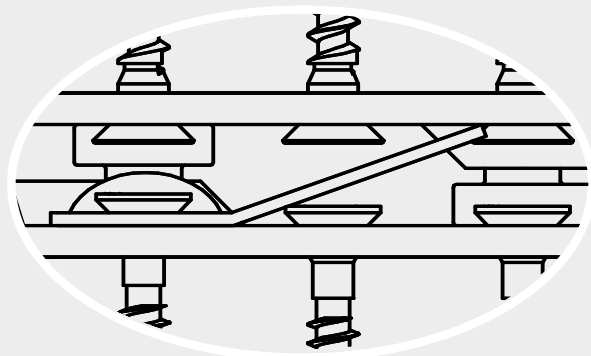
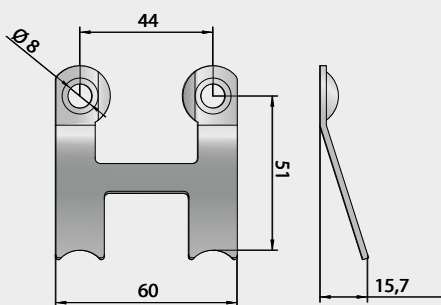

Application: the locking clip locks the connection against slide-in direction and is used for stress against slide-in direction or wind suction.

RICON®S 200/60 VK - Screwed collar bolt

Art.-No.K132

(Dimensions in mm)

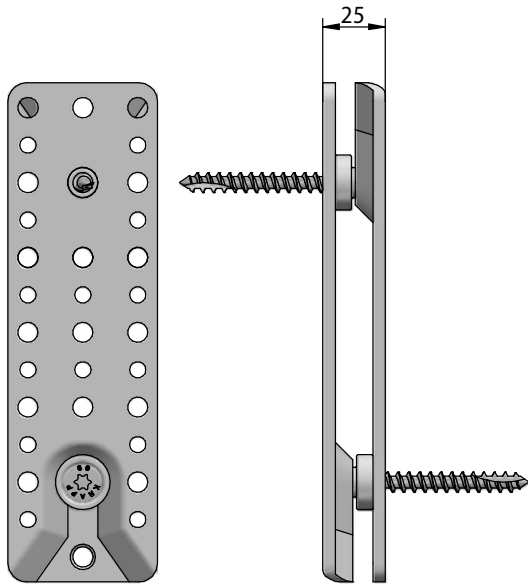

Art.-No.	RICON® S	Collar bolt	Screw connection		Charact. values [GL24h] $F_{2,Rk}$ [kN]
			Joist	Header	
K132 ST	200/60	VK D12	9 x CS 8x160	9 x CS 8x80	34.9
K132 MAX	200/60	VK D12	9 x CS 8x240	9 x CS 8x80	41.4
Axial tension: $F_{1,Rk} = 13.0$ kN					
Clip lock: $F_{3,Rk} = 18.0$ kN					

MIN = minimum screw cxn. ST = standard screw cxn.

Min. timber cross-section: 100 x 220 mm

All design values are available on our website under the Planner Service tab.

Screwed collar bolt

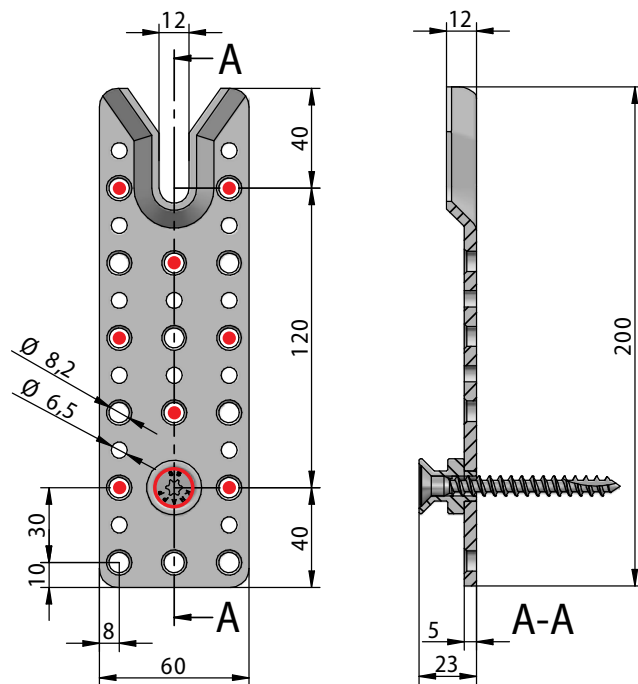
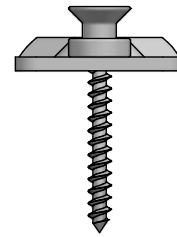

PRODUCT

RICON®S locking clip

RICON®S locking clip 60 (made of stainless spring steel)

Art.-No.K157

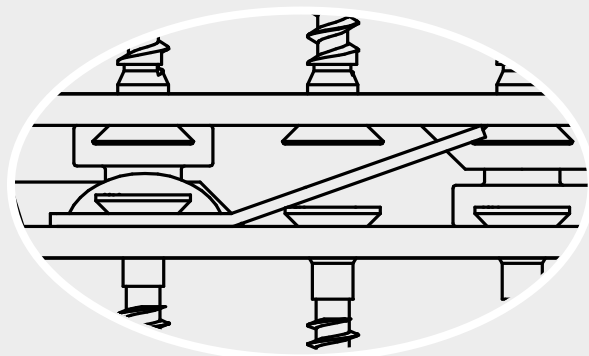
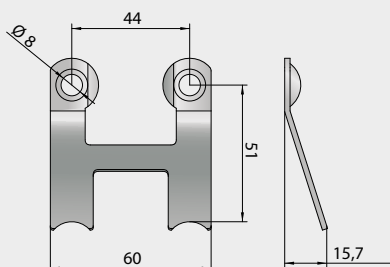

Application: the locking clip locks the connection against slide-in direction and is used for stress against slide-in direction or wind suction.

RICON®S 80 VK

RICON®S 200/80 VK - Screwed collar bolt

Art.-No.K138

(Dimensions in mm)

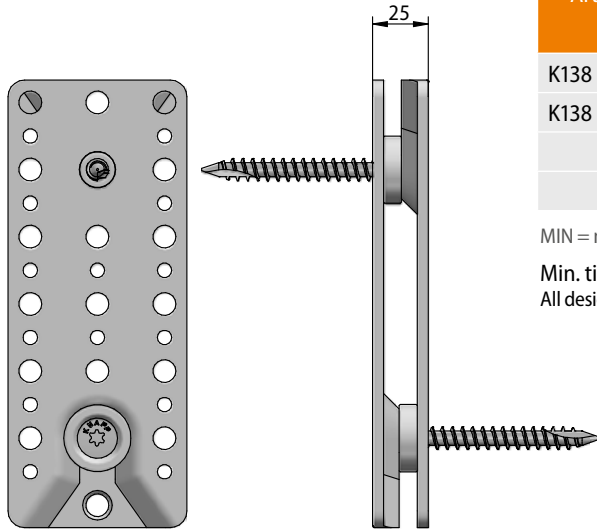

Art.-No.	RICON® S	Collar bolt	Screw connection		Charact. values [GL24h] F _{2,Rk} [kN]
			Joist	Header	
K138 ST	200/80	VK D16	9 x CS 10x200	9 x CS 10x100	48.8
K138 MAX	200/80	VK D16	9 x CS 10x300	9 x CS 10x100	58.4
Axial tension: F _{1,Rk} = 18.7 kN					
Clip lock: F _{3,Rk} = 18.0 kN					

MIN = minimum screw cxn. ST = standard screw cxn.

Min. timber cross-section: 120 x 230 mm

All design values are available on our website under the Planner Service tab.

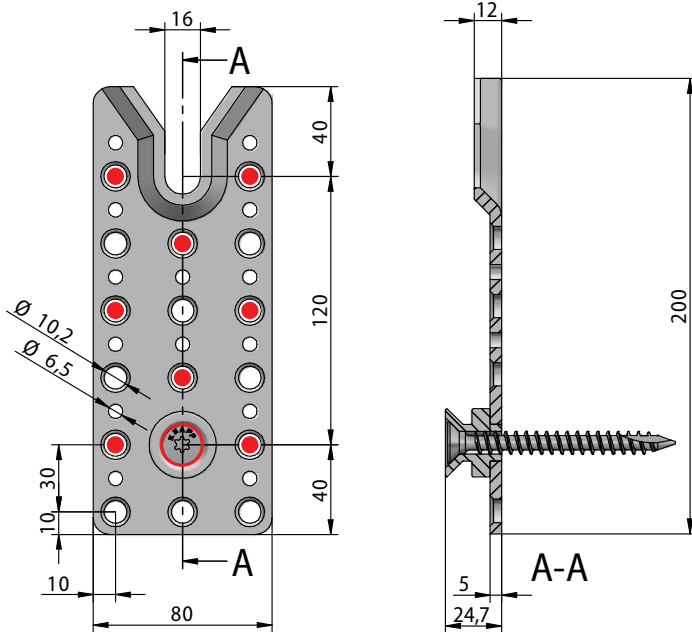
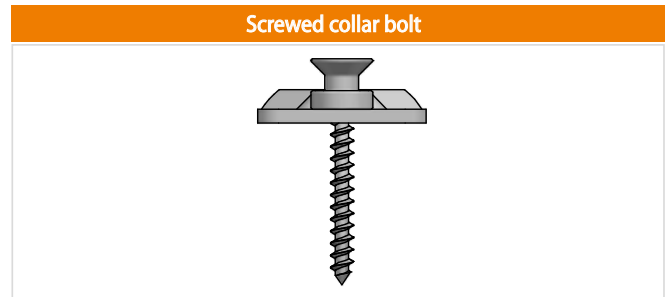

RICON®S locking clip

RICON®S locking clip 80 (made of stainless spring steel)

Art.-No.K158

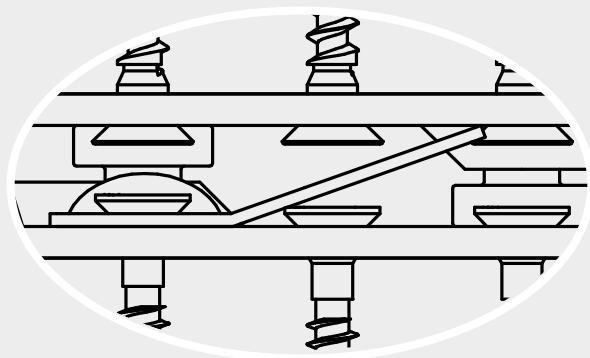
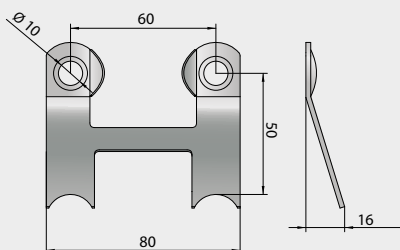

Application: the locking clip locks the connection against slide-in direction and is used for stress against slide-in direction or wind suction.

RICON® S 290/80 VK - Screwed collar bolt

Art.-No.K141

(Dimensions in mm)

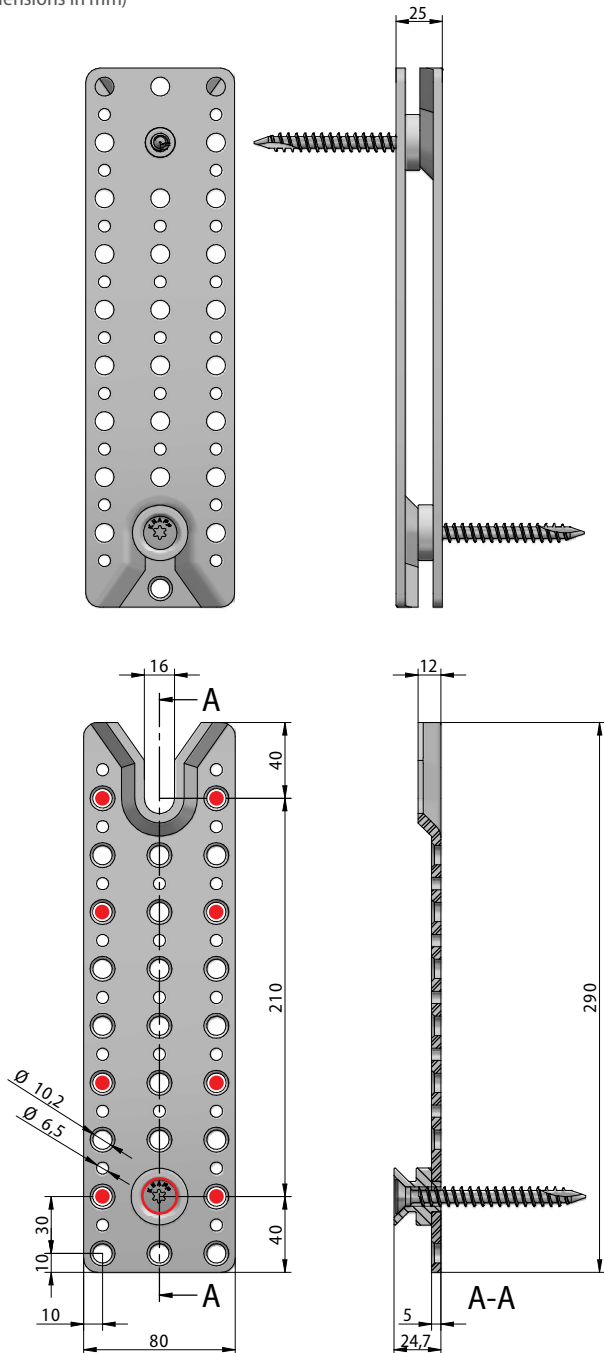

Art.-No.	RICON® S	Collar bolt	Screw connection		Charact. values [GL24h] $F_{2,Rk}$ [kN]
			Joist	Header	
K141 ST	290/80	VK D16	9 x CS 10x200	9 x CS 10x100	48.8
K141 MAX	290/80	VK D16	9 x CS 10x300	9 x CS 10x100	59.7
Axial tension: $F_{1,Rk} = 18.7$ kN					
Clip lock: $F_{3,Rk} = 18.0$ kN					

ST = standard screw cxn. MAX = vissage maximum

Min. timber cross-section: 120 x 320 mm

All design values are available on our website under the Planner Service tab.

Screwed collar bolt

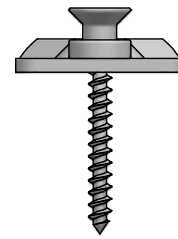

PRODUCT

RICON® S locking clip

RICON® S locking clip 80 (made of stainless spring steel)

Art.-No.K158

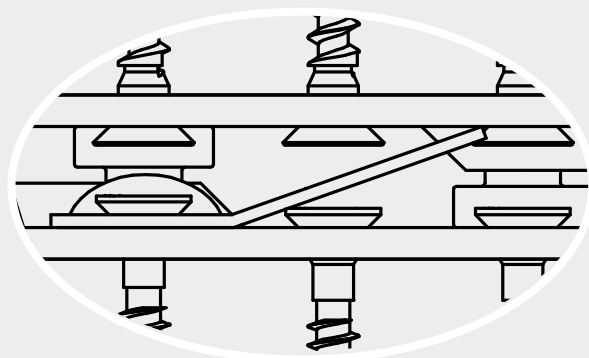
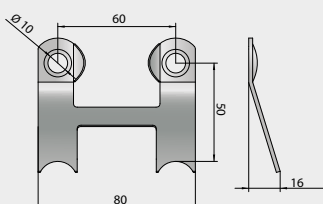

Application: the locking clip locks the connection against slide-in direction and is used for stress against slide-in direction or wind suction.

RICON®S 60 GK

RICON®S 140/60 GK - Spring-loaded collar bolt

Art.-No.K134

(Dimensions in mm)

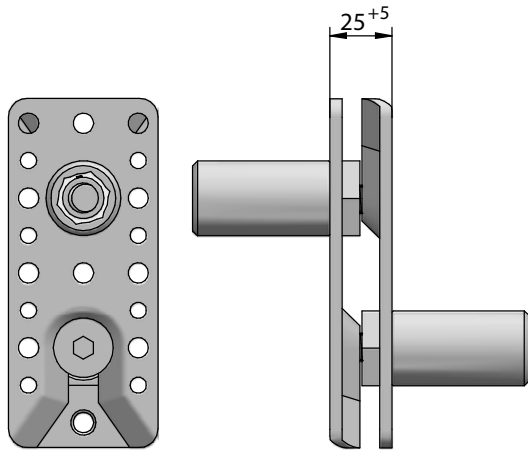

Art.-No.	RICON® S	Collar bolt	Screw connection		Charact. values [GL24h] F _{2,Rk} [kN]
			Joist	Header	
K134 MIN ●	140/60	GK D12	7 x CS 8x160	7 x CS 8x80	26.9
K134 ST	140/60	GK D12	10 x CS 8x160	10 x CS 8x80	37.1
K134 MAX	140/60	GK D12	10 x CS 8x240	10 x CS 8x80	40.2
Axial tension: F _{1,Rk} = 31.5 kN					
Clip lock: F _{3,Rk} = 18.0 kN					

MIN = minimum screw cxn. ST = standard screw cxn. MAX = maximum screw cxn.

Min. timber cross-section: 100 x 160 mm

All design values are available on our website under the Planner Service tab.

Spring-loaded collar bolt for special assembly requirements

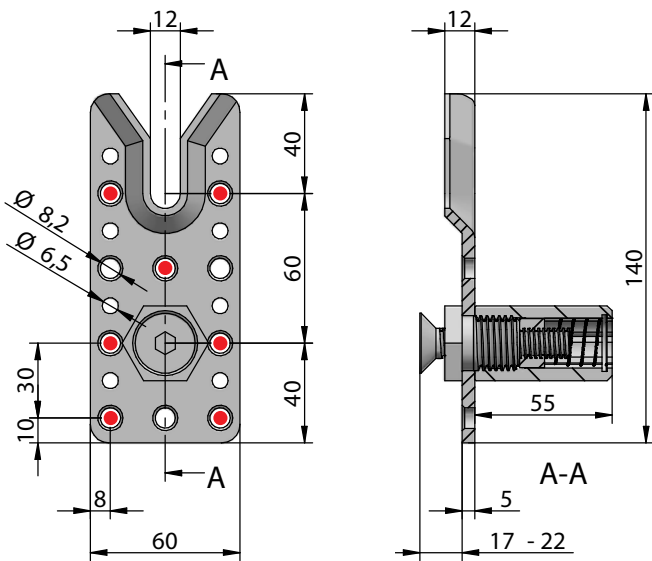
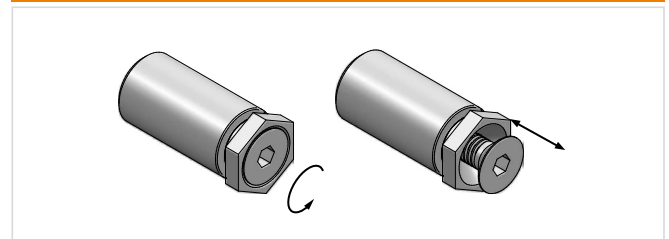

RICON®S locking clip

RICON®S locking clip 60 (made of stainless spring steel)

Art.-No.K157

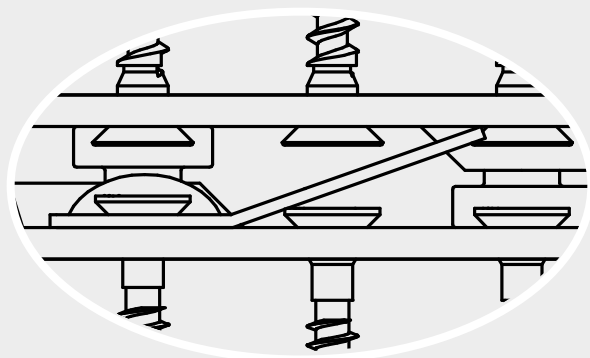
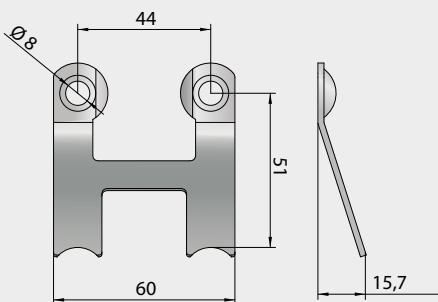

Application: the locking clip locks the connection against slide-in direction and is used for stress against slide-in direction or wind suction.

RICON®S 200/60 GK - Spring-loaded collar bolt

Art.-No.K136

(Dimensions in mm)

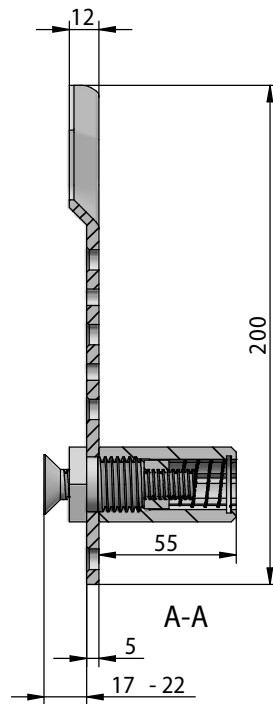
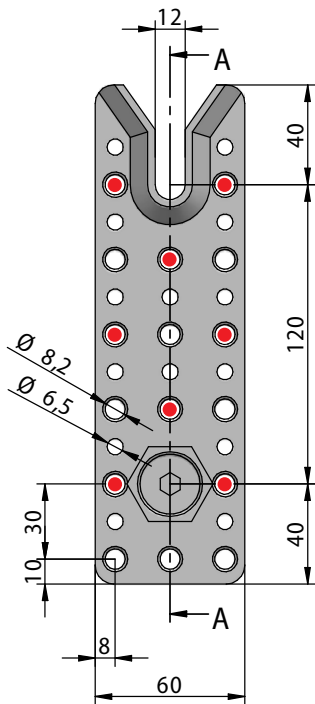
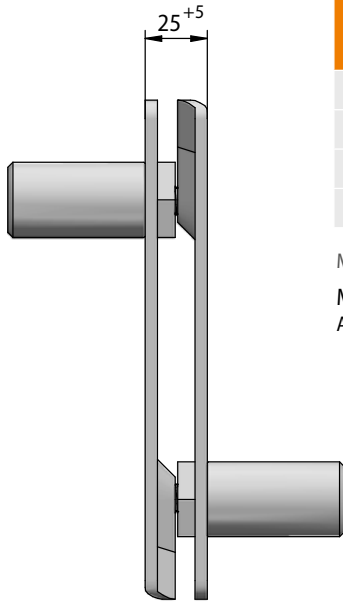
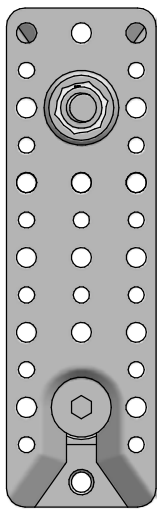

Art.-No.	RICON® S	Collar bolt	Screw connection		Charact. values [GL24h] $F_{2,Rk}$ [kN]
			Joist	Header	
K136 MIN ●	200/60	GK D12	8 x CS 8x160	8 x CS 8x80	30.4
K136 ST	200/60	GK D12	16 x CS 8x160	16 x CS 8x80	44.2
Axial tension: $F_{1,Rk} = 31.5$ kN					
Clip lock: $F_{3,Rk} = 18.0$ kN					

MIN = minimum screw cxn. ST = standard screw cxn.

Min. timber cross-section: 100 x 220 mm

All design values are available on our website under the Planner Service tab.

Spring-loaded collar bolt for special assembly requirements

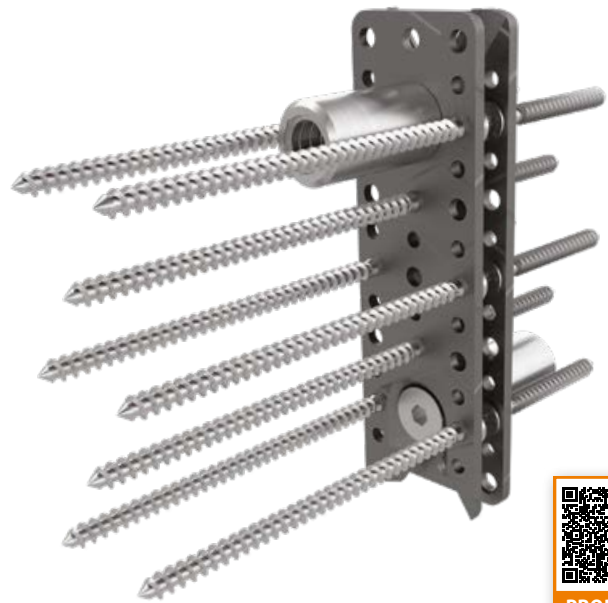
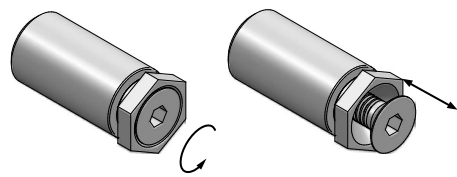

PRODUCT

RICON®S locking clip

RICON®S locking clip 60 (made of stainless spring steel)

Art.-No.K157

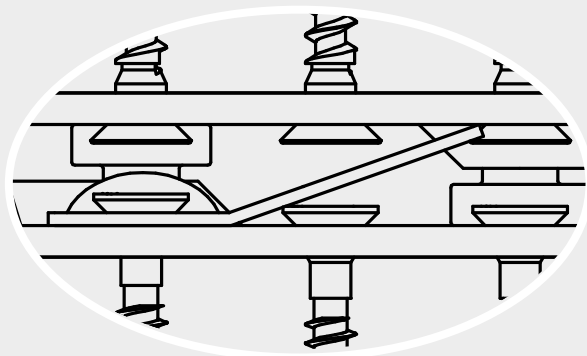
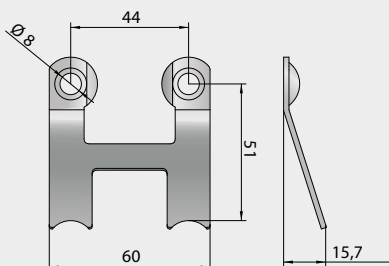

Application: the locking clip locks the connection against slide-in direction and is used for stress against slide-in direction or wind suction.

RICON® S 80 GK

RICON® S 200/80 GK - Spring-loaded collar bolt

Art.-No.K142

(Dimensions in mm)

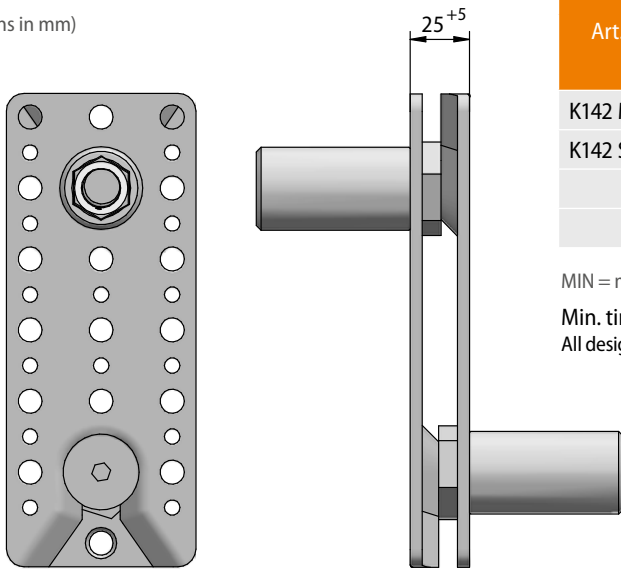

Art.-No.	RICON® S	Collar bolt	Screw connection		Charact. values [GL24h] F _{2,Rk} [kN]
			Joist	Header	
K142 MIN ●	200/80	GK D16	8 x CS 10x200	8 x CS 10x100	42.4
K142 ST	200/80	GK D16	16 x CS 10x200	16 x CS 10x100	65.0
Axial tension: F _{1,Rk} = 36.0 kN					
Clip lock: F _{3,Rk} = 18.0 kN					

MIN = minimum screw cxn. ST = standard screw cxn.

Min. timber cross-section: 120 x 230 mm

All design values are available on our website under the Planner Service tab.

Spring-loaded collar bolt for special assembly requirements

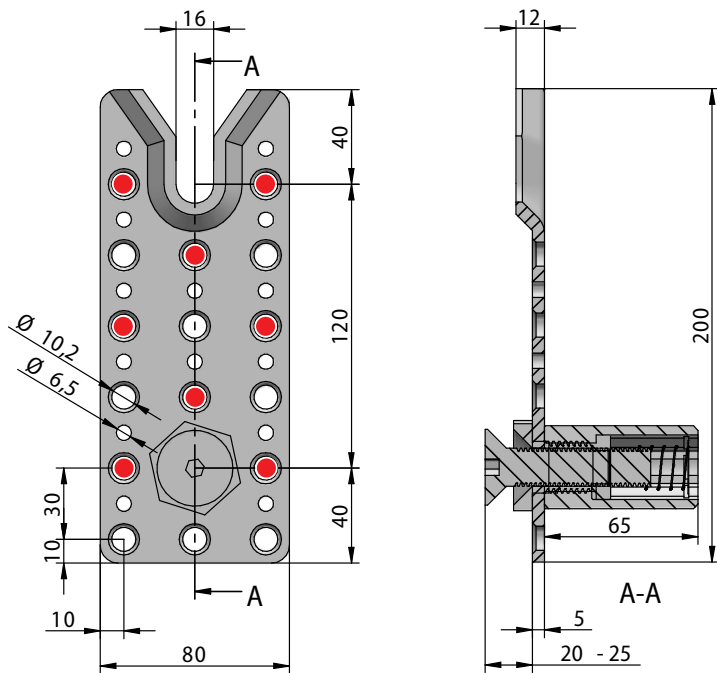
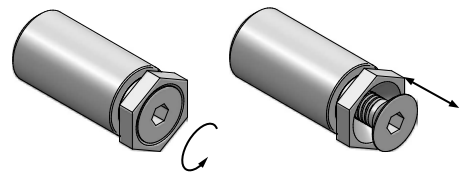

RICON® S locking clip

RICON® S locking clip 80 (made of stainless spring steel)

Art.-No.K158

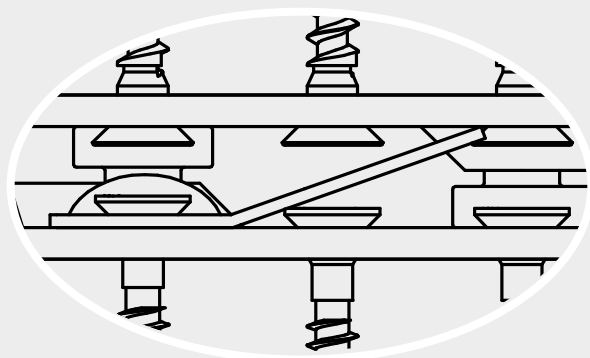
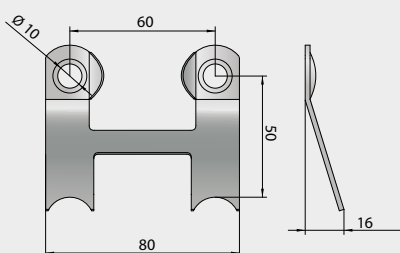

Application: the locking clip locks the connection against slide-in direction and is used for stress against slide-in direction or wind suction.

RICON®S 290/80 GK - Spring-loaded collar bolt

Art.-No.K145

(Dimensions in mm)

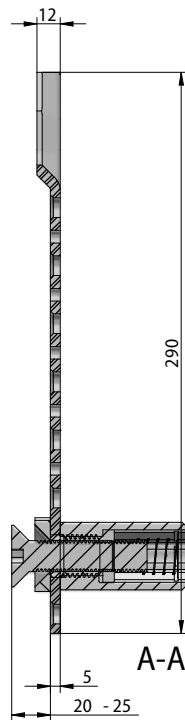
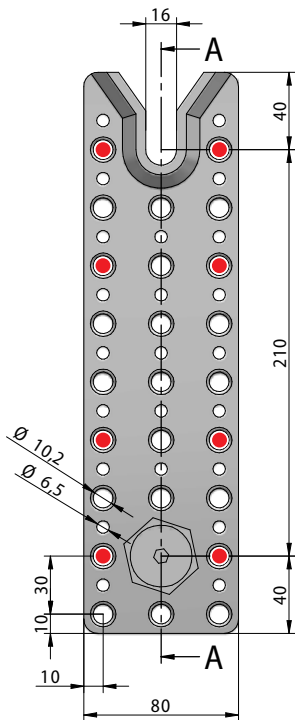
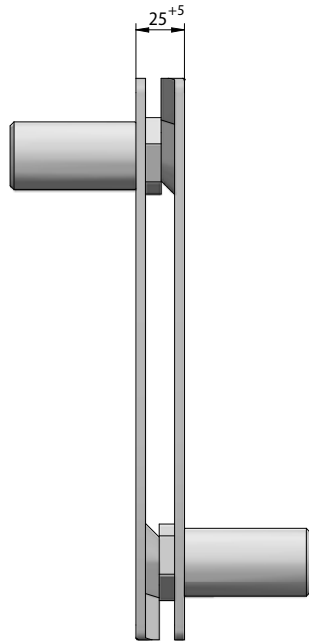
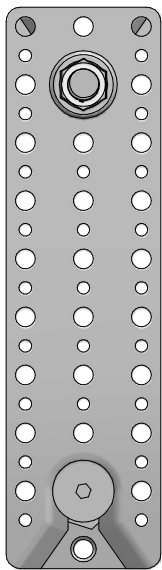

Art.-No.	RICON® S	Collar bolt	Screw connection		Charact. values [GL24h] $F_{2,Rk}$ [kN]
			Joist	Header	
K145 MIN ●	290/80	GK D16	8 x CS 10x200	8 x CS 10x100	42.4
K145 ST	290/80	GK D16	20 x CS 10x200	20 x CS 10x100	72.2
Axial tension: $F_{1,Rk} = 36.0$ kN					
Clip lock: $F_{3,Rk} = 18.0$ kN					

MIN = minimum screw cxn. ST = standard screw cxn.

Min. timber cross-section: 120 x 320 mm

All design values are available on our website under the Planner Service tab.

Spring-loaded collar bolt for special assembly requirements

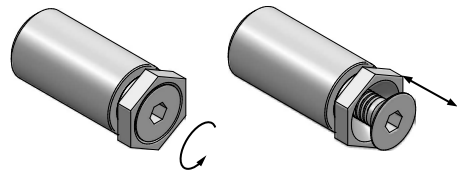

PRODUIT

RICON®S locking clip

RICON®S locking clip 80 (made of stainless spring steel)

Art.-No.K158

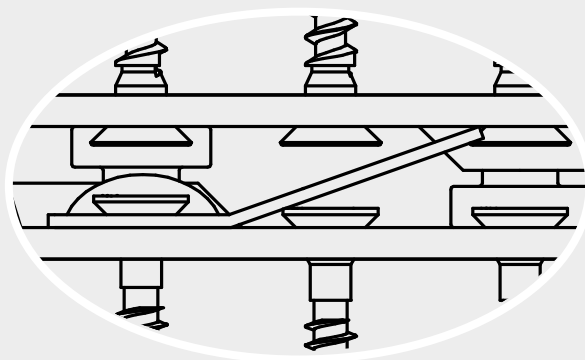
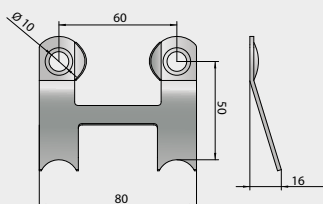

Application: the locking clip locks the connection against slide-in direction and is used for stress against slide-in direction or wind suction.

RICON® S screws

Self-tapping CS-screws RICON® S60 (RICON® S supplied with the respective CS-screws)

Art.-No.Z580	Self-tapping CS-screw 8x80
Art.-No.Z581	Self-tapping CS-screw 8x160
Art.-No.Z530	Self-tapping CS-screw 8x240



Application: to screw the RICON® S into the main beam (mullion) or secondary beam (transom).

CS-screws RICON® S80 with cut point (RICON® S supplied with the respective CS-screws)

Art.-No.Z582	Self-tapping CS-screw 10x100
Art.-No.Z583	Self-tapping CS-screw 10x200
Art.-No.Z651	Self-tapping CS-screw 10x300



Application: to screw the RICON® S into the main beam (mullion) or secondary beam (transom).

RICON® S accessories

Routing-jig for RICON® S 60 / S 80

Art.-No.K510	Routing-jig MULTI F60 (plywood) for all RICON® S60 sizes
Art.-No.K511	Routing-jig MULTI F80 (plywood) for all RICON® S80 sizes

Tip: The MULTI F routing-jig is suitable for a Ø 30 mm guide bushing (for plunge router) and Ø 15 mm TCT straight router bit. MULTI F is adjustable depending on wood sizes.



Application: or milling with concealed mounting.

TCT slotting cutter

Art.-No.Z068	TCT slotting cutter Ø15, Length of 40 mm and Ø12 mm shaft
--------------	---



Application: to recess the rebate for RICON® S.

Full threaded CS-screws with cut-point

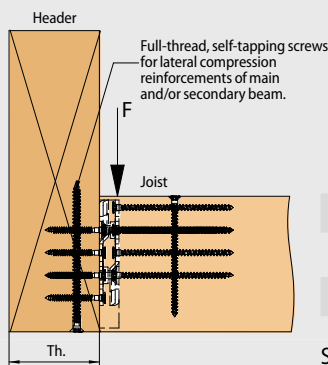

Diameter (d1)	Length (mm)													
Ø 8 mm	160	180	200	220	240	260	280	300	350	400	450	500	550	600
Ø 10 mm	160	180	200	220	240	260	280	300	350	400	450	500	550	600

Sizes available upon request.

Application: full threaded countersunk screws for lateral compression reinforcements of header and/or joist.

RICON® S steel to timber connection

Beam connections to steel pillar

F-Load direction

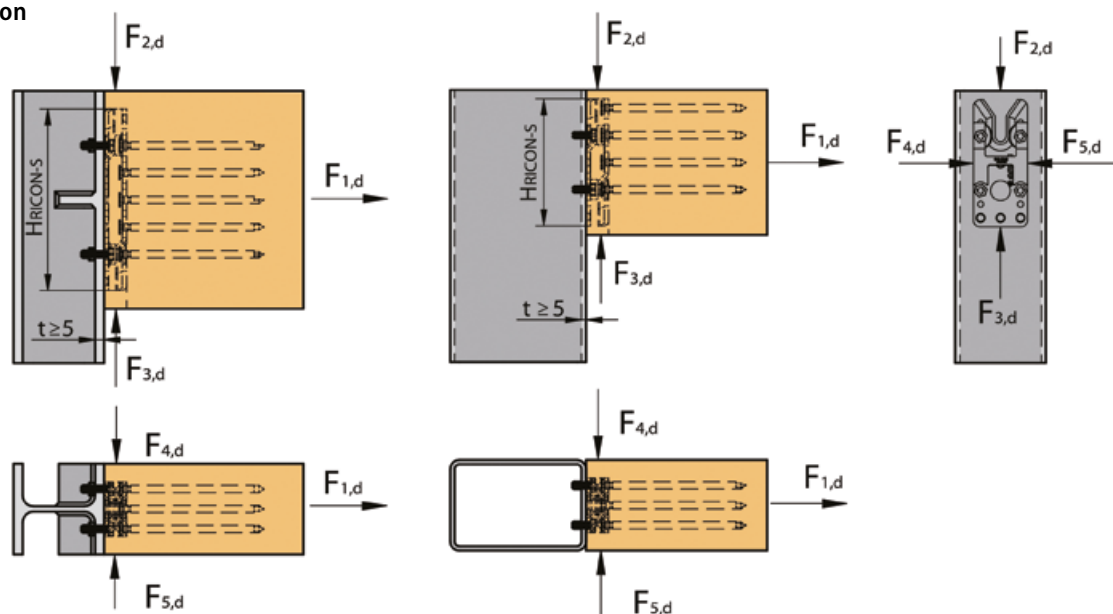

Wood to steel connection in slide-in direction F_2

Load bearing capacities in the direction of insertion

KNAPP® Connectors	Tensile force in secondary beam		Shear force	
	$F_{t,Rk}$ [kN]* on 5 mm steel	$F_{1,Rk}$ [kN]* on glulam GL24h	$F_{v,Rk}$ [kN]* on 5 mm steel	$F_{2,Rk}$ [kN]* on glulam GL24h
RICON® S 140x60 EK* /VS 4 screws M8x20 10 CS 8x160	72.4	31.5	42.2	37.1
RICON® S 200x60 EK* /VS 6 screws M8x20 16 CS 8x160	108.6	31.5	63.4	EK: 44.2 VS: 56.7
RICON® S 200x80 EK* /VS 4 screws M10x20 16 CS 10x200	90.5	36.0	111.4	EK: 65.0 VS: 79.1
RICON® S 290x80 EK* /VS 6 screws M10x20 25 CS 10x200	135.7	36.0	167.0	EK: 72.2 VS: 118.2
RICON® S 390x80 VS+ZP 6 vis M10x20 28 CS 10x200 2 CS 10x450	135.7	36.0	167.0	170.9
Sizing value calculation	$\gamma_{M,2} = 1.25$	$\gamma_M = 1.3$	$\gamma_{M,2} = 1.25$	$\gamma_M = 1.3$
		$k_{mod} = 0.8$ KLED medium		$k_{mod} = 0.8$ KLED medium
		$k_{mod} = 0.9$ KLED short		$k_{mod} = 0.9$ KLED short

* The indicated values are applicable to the RICON® S EK version (retaining screw collar bolt with insert screw).

Notes about pages 85 to 87.

The fischer anchors for KNAPP® wood-concrete connections were defined with the dimensions shown on the drawings and a concrete strength class of C20/25. The calculations were made with the C-FIX design tool and verified by fischer. All other configurations must be checked. This can be done by KNAPP®, fischer or a professional (engineer or competent technician). KNAPP® accepts no liability for the inappropriate use of the value tables given in this catalogue. The condition of the concrete element (concrete strength class and surface) must be checked by a specialist. KNAPP® accepts no liability in this respect. KNAPP® products and connectors must be installed according to the installation instructions manuals. KNAPP® - fischer wood-concrete joints must be made in accordance with their respective ETA technical evaluations.

RICON® S timber to concrete connection

Timber Engineering

(Dimensions in mm)

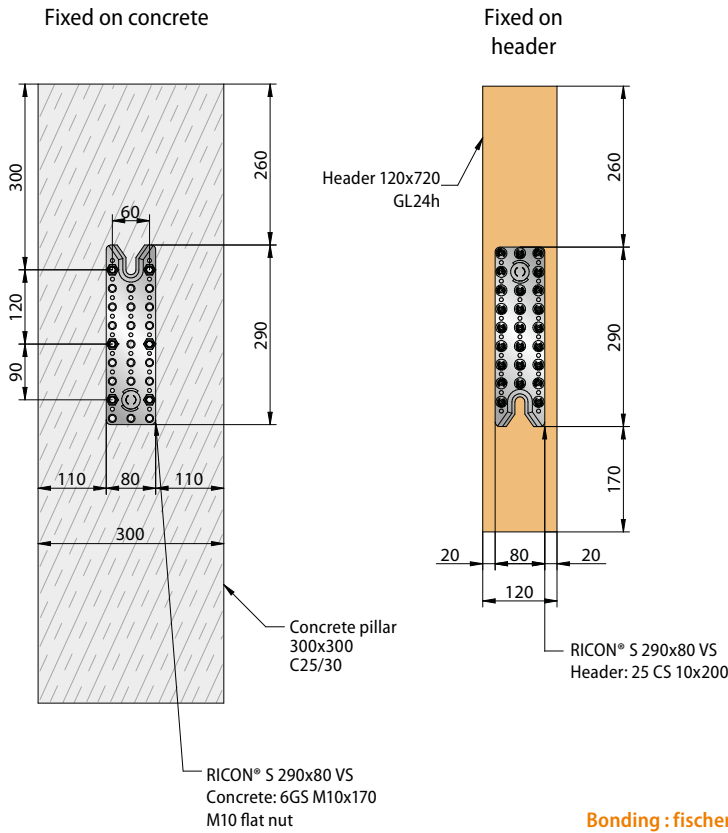

Bonding : fischer
Superbond-System
FIS SB 390 S

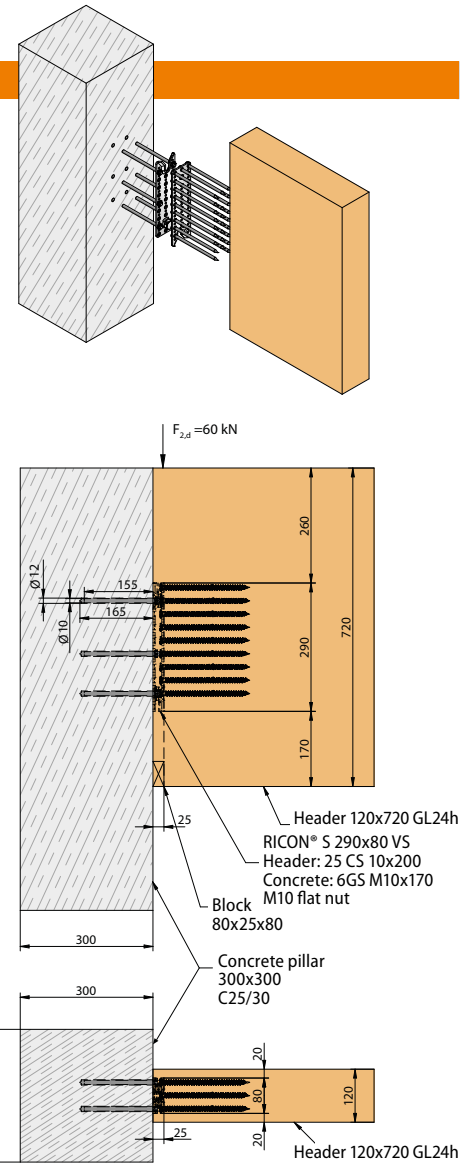

RICON® S

Timber Engineering

(Dimensions in mm)

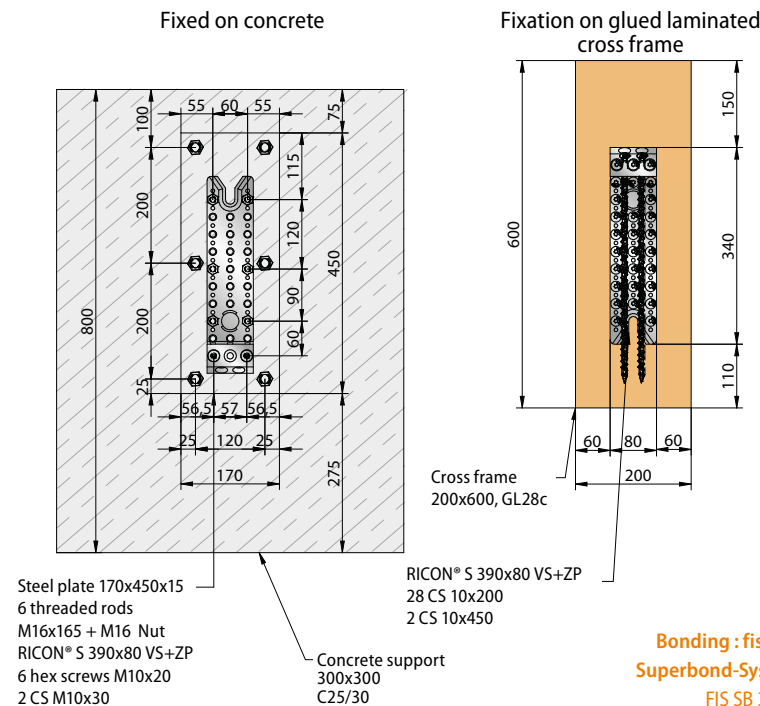

Bonding : fischer
Superbond-System
FIS SB 390 S

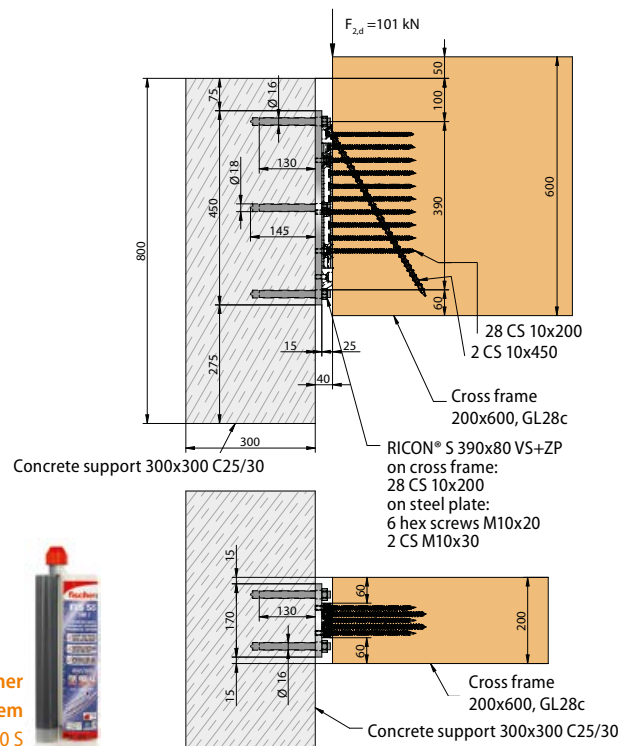

RICON® S 60 and 80 VS timber to concrete connection

Beam to concrete connection

(Dimensions in mm)

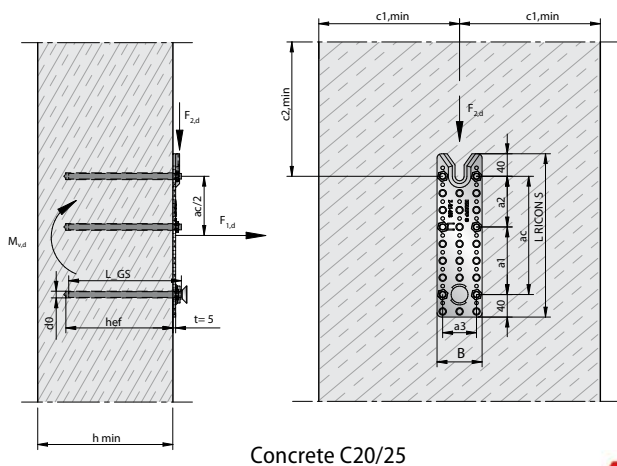

Distance	Distances for RICON® S Version VS concrete connection			
	140x60 [mm]	200x60 [mm]	200x80 [mm]	290x80 [mm]
Spacing a_c	60	120	120	210
Spacing a_1	60	60	60	120
Spacing a_2	0	60	60	90
Spacing a_3	44	44	60	60
Drill hole diameter d_0	10	10	12	12
Anchorage depth h_{ef}	140	140	160	160
Diameter threaded rod d_{GS}	M8	M8	M10	M10
Length threaded rod L_{GS}	150	150	170	170
Minimal edge distance $c_{1,min}$	∞	∞	∞	∞
Minimal edge distance $c_{2,min}$	100	100	100	135
Minimal concrete thickness h_{min}	170	170	190	190

fischer Approval: ETA-12/0258 (fischer)

fischer Superbond-System FIS SB 390 S

RICON® S 60: threaded rod M8x150 with M8, 8.8 nut

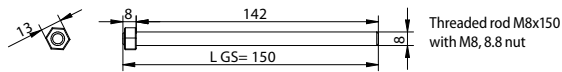

fischer Superbond-System FIS SB 390 S

RICON® S 80: threaded rod M10x170 with M10, 8.8 nut

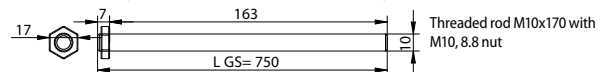

F₂ Load direction in the direction of insertion

KNAPP® Connectors	Concrete connection		Timber connection						
	F _{2,Rd,concrete}	Distances	Wood material		F _{2,Rd,timber}				
	Shear force F _{2,Rd,concrete} [kN]	Bending moment with e = 0,025 m M _{v,Rd,concrete} [kNm]	Wood type	Char. density ρ_k [kg/m³]	Charact. values [kN]		Design values F _{2,Rd, V_M = 1,3} [kN]		
					F _{2,KCC,Rk} , V_M = 1,0	F _{2,Rk}	k _{mod} = 0,6	k _{mod} = 0,8	k _{mod} = 0,9
RICON® S 140/60 VS ST Concrete: 4 threaded rods M8x150	34,00	0,85	C24	350	60	34,9	16,1	21,5	24,2
			GL24h	385					
RICON® S 140/60 VS MAX Concrete: 4 threaded rods M8x150	34,00	0,85	C24	350	60	37,8	17,4	23,3	26,2
			GL24h	385					
RICON® S 200/60 VS ST Concrete: 6 threaded rods M8x150	50,00	1,25	C24	350	60	53,3	24,6	32,8	36,9
			GL24h	385					
RICON® S 200/60 VS MAX Concrete: 6 threaded rods M8x150	50,00	1,25	C24	350	60	62,7	28,9	38,6	43,4
			GL24h	385					
RICON® S 200/80 VS ST Concrete: 6 threaded rods M10x170	68,00	1,70	C24	350	99	74,7	34,5	46,0	51,7
			GL24h	385					
RICON® S 200/80 VS MAX Concrete: 6 threaded rods M10x170	68,00	1,70	C24	350	99	87,1	40,2	53,6	60,3
			GL24h	385					
RICON® S 290/80 VS ST Concrete: 6 threaded rods M10x170	95,00	2,38	C24	350	99	111,2	51,3	68,4	77,0
			GL24h	385					
RICON® S 290/80 VS MAX Concrete: 6 threaded rods M10x170	95,00	2,38	C24	350	99	134,7	62,2	82,9	93,3
			GL24h	385					
RICON® S 390/80 VS ST Concrete: 6 threaded rods M10x170	110,00	2,75	C24	350	180	162,8	75,2	100,2	112,7
			GL24h	385					
RICON® S 390/80 VS MAX Concrete: 6 threaded rods M10x170	110,00	2,75	C24	350	180	187,5	86,1	114,7	129,1
			GL24h	385					

Number of screws in joist are given on pages 52 to 66.

Service class timber: 1-2

$V_{M,timber} = 1,3$

Calculation of F_{2,Rd} for timber-concrete connection:

$$F_{2,Rd} = \min \left\{ \begin{array}{l} \min F_{2,Rd,timber} \\ \min F_{2,Rd,beton} \end{array} \right.$$

$$F_{2,Rd,timber} = \min \left\{ \begin{array}{l} \min F_{2,KCC,Rk} / V_M \\ \min F_{2,Rk} \cdot k_{mod} \end{array} \right. / V_{M,timber}$$

Fixation RICON® S 60 and 80 VS timber to concrete connection

Beam to concrete connection

(Dimensions in mm)

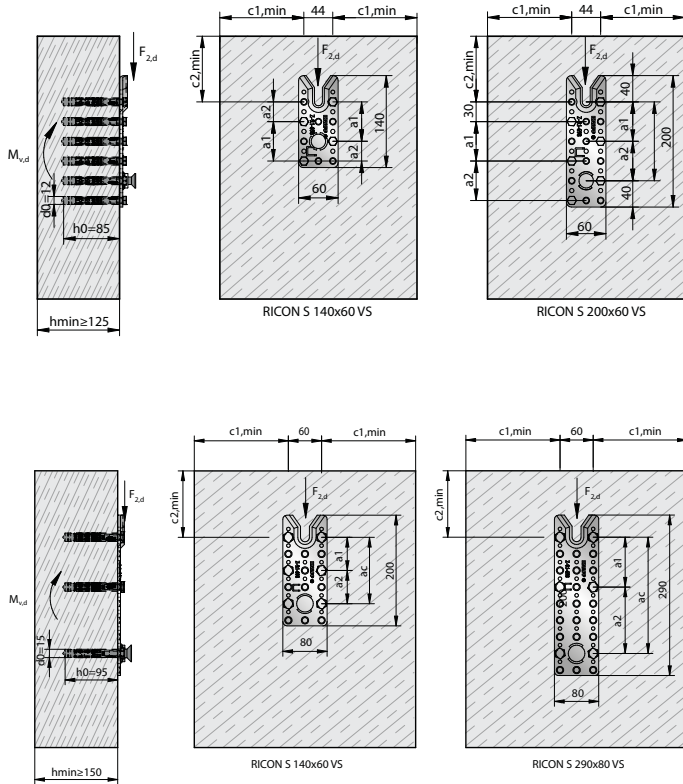

Distance	Distances for RICON® S Version VS concrete connection			
	140x60 [mm]	200x60 [mm]	200x80 [mm]	290x80 [mm]
Spacing a_c	60	120	120	210
Spacing a_1	60	60	60	90
Spacing a_2	30	60	60	120
Spacing a_3	44	44	60	60
Drill hole diameter d_o	12	12	15	15
Anchorage depth h_{ef}	85	85	95	95
Diameter threaded rod d_{GS}	M8x20	M8x20	M10x20	M10x20
Minimal edge distance $c_{1,min}$	∞	∞	∞	∞
Minimal edge distance $c_{2,min}$	100	100	120	120
Minimal concrete thickness h_{min}	125	125	150	150

fischer Approval: ETA-07/0025 and ENSO

RICON® S 60:
fischer high performance anchor FH II 12/ M8 I (8.8)
with hexagon screw M8x20

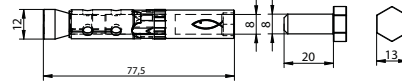

RICON® S 80:
fischer High performance anchor FH II 15/ M10 I (8.8)
with hexagon screw M10x20

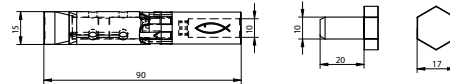

F₂ Load direction in the direction of insertion

KNAPP® Connectors	Concrete connection		Timber connection						
	F _{2,Rd,concrete}	Distances	Wood material		F _{2,Rd,timber}				
	Shear force F _{2,Rd,concrete} [kN]	Bending moment with e = 0,025 m M _{V,Rd,concrete} [kNm]	Wood type	Char. density ρ_k [kg/m ³]	Charact. values [kN]		Design values F _{2,Rd} , Y _M = 1,3 [kN]		
					F _{2,KCC,Rk} * Y _M = 1,0	F _{2,Rk}	k _{mod} = 0,6	k _{mod} = 0,8	k _{mod} = 0,9
RICON® S 140/60 VS ST Concrete: 4 FH II 12/M8 I	22,00	0,55	C24	350	60	34,9	16,1	21,5	24,2
GL24h			385	37,1		17,1	22,8	25,7	
RICON® S 140/60 VS MAX Concrete: 4 FH II 12/M8 I	22,00	0,55	C24	350	60	37,8	17,4	23,3	26,2
GL24h			385	40,2		18,6	24,7	27,8	
RICON® S 200/60 VS ST Concrete: 6 FH II 12/M8 I	35,00	0,88	C24	350	60	53,3	24,6	32,8	36,9
GL24h			385	56,7		26,2	34,9	39,3	
RICON® S 200/60 VS MAX Concrete: 6 FH II 12/M8 I	35,00	0,88	C24	350	60	62,7	28,9	38,6	43,4
GL24h			385	66,5		30,7	40,9	46,0	
RICON® S 200/80 VS ST Concrete: 6 FH II 15/M10 I	44,00	1,10	C24	350	99	74,7	34,5	46,0	51,7
GL24h			385	79,1		36,5	48,7	54,8	
RICON® S 200/80 VS MAX Concrete: 6 FH II 15/M10 I	44,00	1,10	C24	350	99	87,1	40,2	53,6	60,3
GL24h			385	92,4		42,6	56,9	64,0	
RICON® S 290/80 VS ST Concrete: 6 FH II 15/M10 I	60,00	1,50	C24	350	99	111,2	51,3	68,4	77,0
GL24h			385	118,2		54,6	72,7	81,8	
RICON® S 290/80 VS MAX Concrete: 6 FH II 15/M10 I	60,00	1,50	C24	350	99	134,7	62,2	82,9	93,3
GL24h			385	142,7		65,9	87,8	98,8	

Number of screws in joist are given on pages 52 to 66.

Service class timber: 1-2

Y_{M,timber} = 1,3

Calculation of F_{2,Rd} for timber-concrete connection:

$$F_{2,Rk} = \min \left\{ \begin{array}{l} \min F_{2,Rd, timber} \\ \min F_{2,Rd, concrete} \end{array} \right. \quad F_{2,Rk, bois} = \min \left\{ \begin{array}{l} \min F_{2,KCC, Rk} / Y_M \\ \min F_{2,Rk} \cdot k_{mod} \end{array} \right. / Y_{M, timber}$$

RICON®S

Fabrication

- Routing machine with KNAPP® routing-jig.
- Fabrication with CNC joinery machine possible – all data for the standard CNC joinery machine programs are included.



CNC joinery machine



The milling template and router make a 60 mm or 80 mm wide and 25 mm deep cutout on the secondary beam (length according to the assembly instructions).

Min. routing dimensions for RICON® S60 / S80

Width	Length	Depth (VS, VK, EK, GK)
60 mm / 80 mm	variable	25 mm

Installation RICON® S VK



Position the plate and the screws



Screw on RICON®S on Header



Screw on RICON®S counter part on joist

RICON®S wood to steel connection



RICON®S 290/80 - timber to steel connection

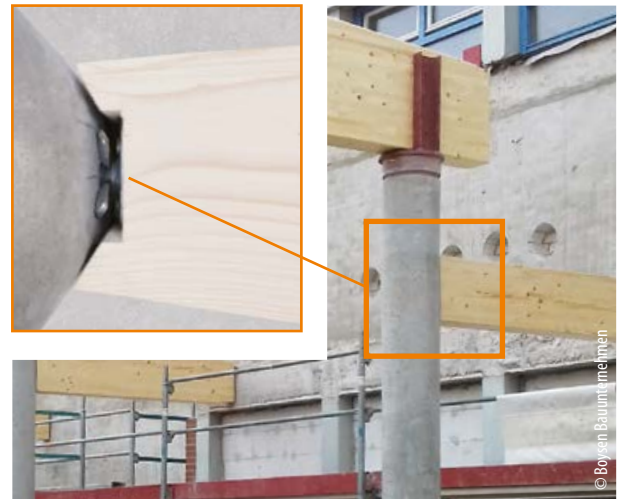

RICON®S - timber to concrete connection

The heavy-duty system for timber construction engineering

Connecting main beam to secondary beam up to 768 kN*

- | Wood width up from 100 mm
- | Invisible - finition d'assemblage impeccable
- | Démontage and remontage sans dommage
- | Préfabrication très avancée de la production
- | Montage possible dans tous les sens sans coincement
- | Reprend des efforts sur tous les axes
- | Accroche facile and rapide, distance d'emboitement seulement 20 mm
- | Résistant au feu (EN 1995-1-2)

MEGANT[®]

Available in 11 sizes.

The values only apply when used with original KNAPP[®] screws! Design values are available on our website under Planner Service.

* Characteristic value $F_{2,Rk}$ in slide-in direction according to ETA-15/0667 (2023/08/16), for glulam GL24.



MEGANT®

- ▮ Applications: concealed main-secondary beam connections
- ▮ Connection: wood to wood and wood to concrete and steel
- ▮ Areas of application: timber engineering, multi-storey timber construction
- ▮ Service class 1 and 2



Hasslacher © Thompson

Installation example with MEGANT®:
No weakening of the main beam.

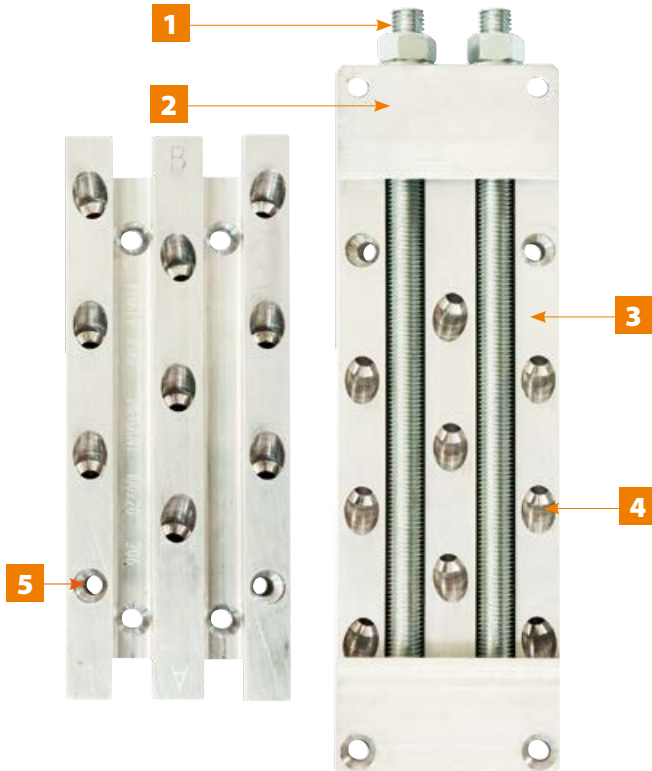

- 1 Threaded rod with washers and hexagonal nuts transmit the tensile forces.
- 2 Tapered aluminium clamping jaws transfer the vertical and tensile forces from the secondary beam to the main beam and form a tight joint between the two connector plates. In addition, the clamping jaws can be used to rest the beam during assembly.
- 3 Connector plates made of high-strength aluminium with fastening holes for fully threaded screws at 45° and 90° angle.
- 4 Biaxially inclined screw pattern to avoid splitting of the main beam or column.
- 5 Horizontal screws for transferring the tensile forces from the clamping moment.

Fire protection: fire resistance (EN 1995-1-2) through 3-4 sided concealed, tight-joint mounting (R30 ≥ 28 mm, R60 ≥ 49 mm)



MEGANT®

MEGANT® standard dimensions

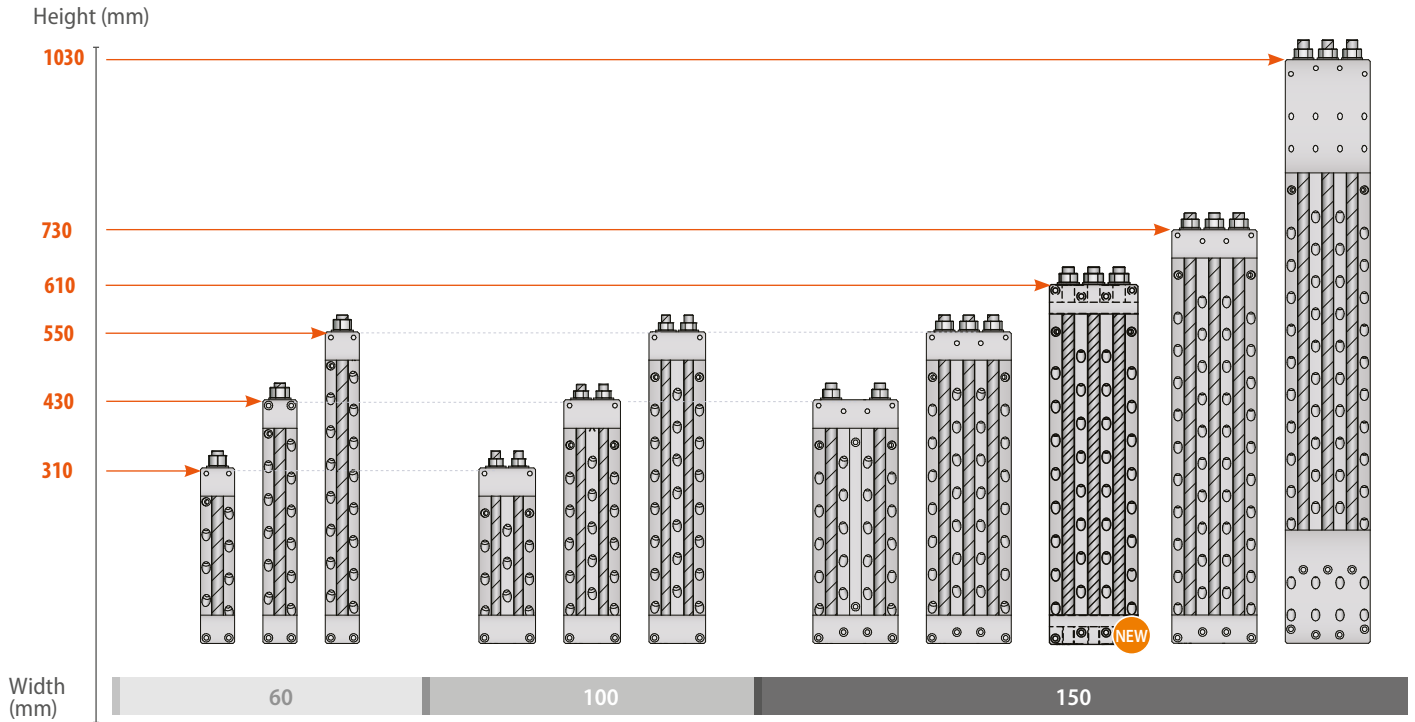

Connector components

Position	Description
1	Hexagonal nut
2	Washers
3	Clamping jaw (without thread)
4	Threaded rod
5	Connector plate x 2
6	Bottom clamping jaw (with thread)

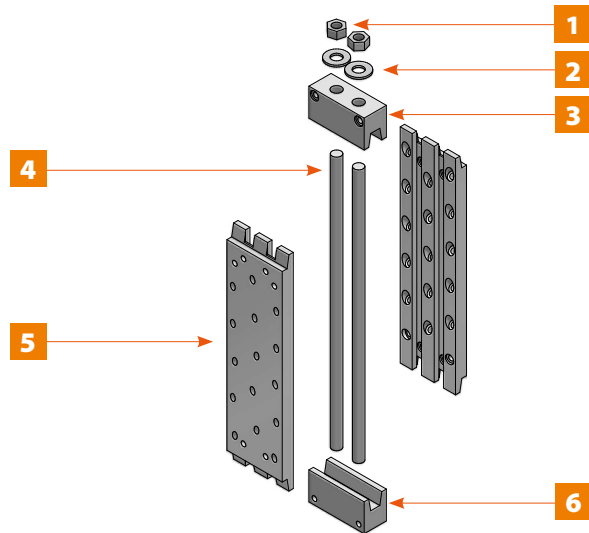

Vis MEGANT®

MEGANT® self-tapping CS-screw (corresponding CS-screws are included with MEGANT®)

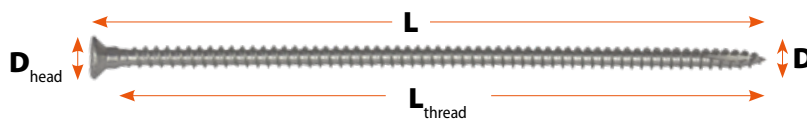

Art.-No.	Type	D _{head}		L		L _{thread}		D		Bits
		mm	[in]	mm	[in]	mm	[in]	mm	[in]	
Z581	Self-tapping CS-screw	15	0.59	160	6.30	145	5.70	8	0.31	Torx 40
Z530	Self-tapping CS-screw	15	0.59	240	9.45	225	8.86	8	0.31	Torx 40
Z670/Z675	Self-tapping CS-screw	15	0.59	120	9.45	105	4.13	8	0.31	Torx 40

Application: for positioning screws and diagonal screws as well as assembling the clamping jaw of the MEGANT®.

MEGANT®

Application examples and connection details



With only 2 cm of hooking way, an installation in recesses of concrete walls can be done.



© Photo: Hess Bois

Three-sided concealed assembly by milling into the secondary beam. MEGANT® is fixed to the main beam with no need for milling.



MEGANT® angled connection.

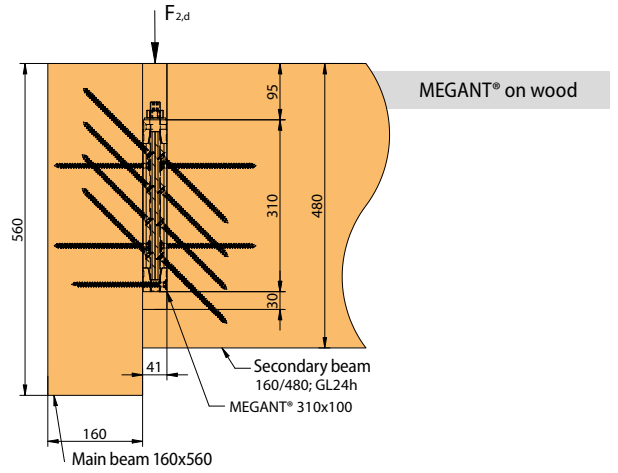

MEGANT® steel connection.

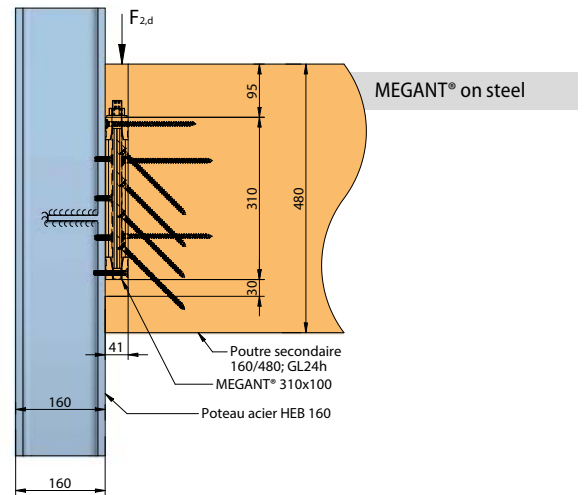

Double-sided beam column connection with MEGANT®

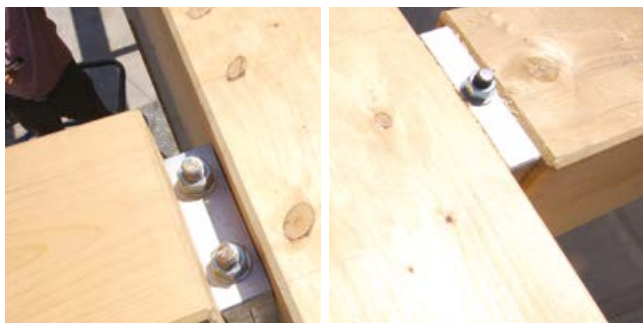

Top flush double-sided main and secondary beam MEGANT® connection.

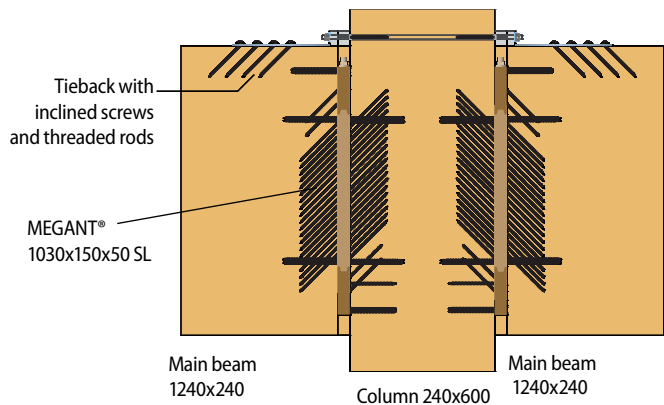

MEGANT®

Wood to concrete and steel connection

Example of a sloped beam/concrete connection with MEGANT®

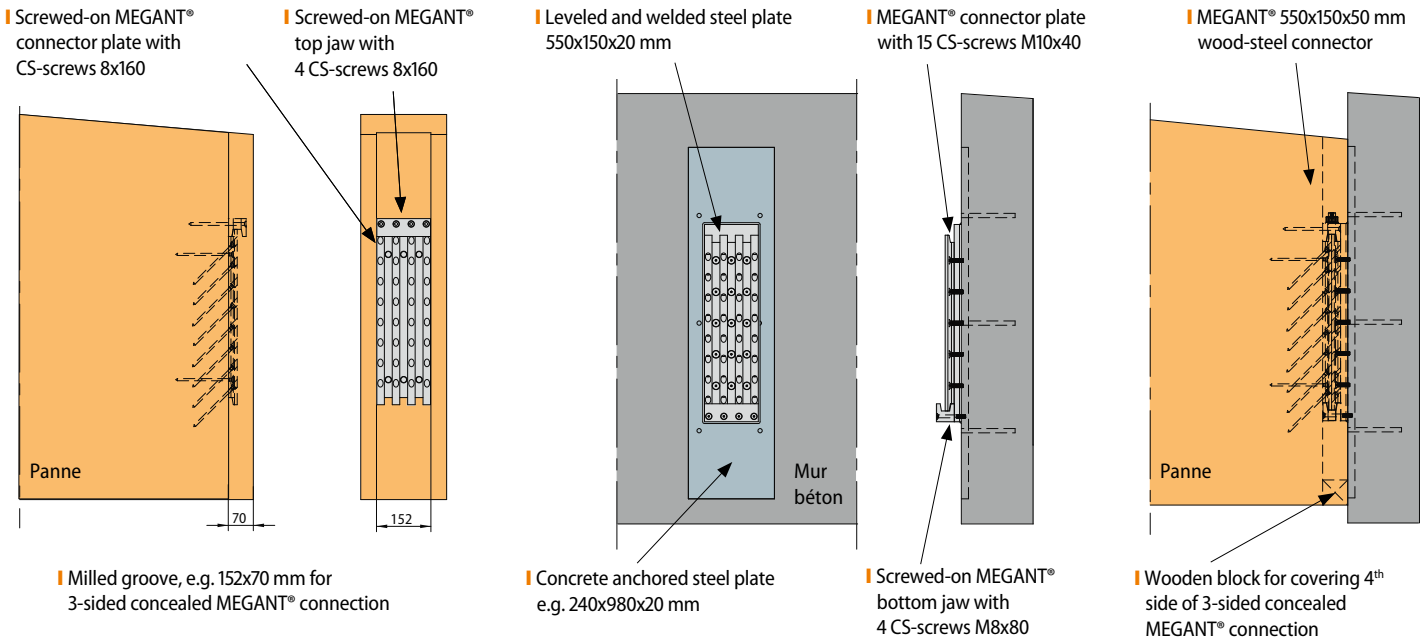

Examples of anchor plate concrete connection



MEGANT® concrete connection.



Adhesive: **fischer Superbond-System FIS SB 390 S**

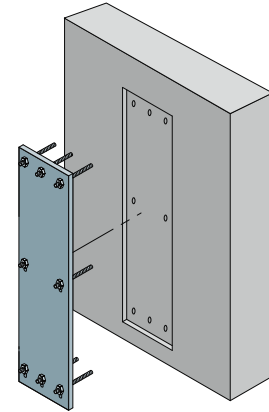

Concrete connection with glued-in threaded rods for levelling the fischer steel plate - optionally set in recessed concrete. Bonded with fischer Superbond System: FIS SB 390 S www.fischer-international.com/en/

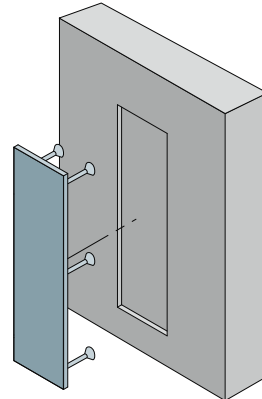

SBKL anchor plate from Peikko (DE) Steel plate embedded in concrete. www.peikko.de

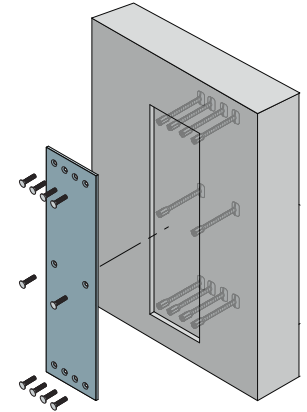

Halfen HSC-B steel construction connection with CS screw connection set in recessed concrete. www.halfen.com

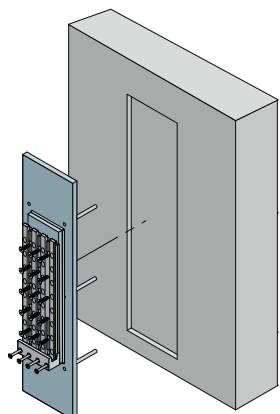

Sloped beam attached to concrete. The welded steel plate gives additional support as well as a surface for connecting the MEGANT® with screws.

The anchoring of the anchor steel plate can be done e.g. with HALFEN HSC-B steel construction connection according to approval Z-1.8-1974, or with fischer Superbond FIS SB 390 S glued-in threaded rods. The required structural analysis for this concrete connection must be carried out by a structural engineer on site.

In the case of a steel plate levelled and installed precisely in the concrete structure, this steel plate can serve as an anchor plate for the concrete connection and thus a complex welding on site can be avoided. This means that the MEGANT® connector only has to be screwed onto the levelled anchor plate.

MEGANT®

Load bearing capacity values for MEGANT installed on softwood, according to ETA-15/0667 (16.08.2023)

MEGANT® 60 series – Aluminium EN AW 6082

MEGANT® mm	Softwood material	Characteristic load bearing capacity and stiffness in softwood with KNAPP® screws 8 x 160 mm								
		$F_{1,KCC,Rk}$ kN	$F_{1,Rk}$ kN	$F_{2,KCC,Rk}$ kN	$F_{2,Rk}$ kN	$F_{3,Rk}$ kN	$F_{4KCC,Rk}$ kN	$F_{4,Rk}$ kN	$M_{tor,Rk}$ kNm	$K_{tor,ser}$ kNm/rad
310x60x40	C24	36,6	18,9	150,4 ¹⁾	89,7	28,0	36,9	32,0	2,5	200
	GL24h		20,4		96,8	29,1		33,6	2,7	227
430x60x40	C24		18,9	130,1 · f_{R2} ²⁾	141,0	37,1	40,6	50,4	5,5	639
	GL24h		20,4		152,1	38,7		52,8	5,8	723
550x60x40	C24		18,9		192,2	46,3	44,3	68,7	9,6	1 569
	GL24h		20,4		207,4	48,3		72,0	10,2	1 775

 $F_{1,KCC,Rk}/F_{1,Rk}$ Characteristic load bearing capacity (aluminium failure/wood failure) in direction of secondary beam $F_{2,KCC,Rk}/F_{2,Rk}$ Characteristic load bearing capacity (aluminium failure/wood failure) in direction of insertion $F_{3,Rk}$ Characteristic load bearing capacity (wood failure) against direction of insertion $F_{4,KCC,Rk}/F_{4,Rk}$ Characteristic load bearing capacity (aluminium failure/wood failure) perpendicular to direction of insertion M_{tor} Characteristic rotation moment

MEGANT® 100 series – Aluminium EN AW 6082

MEGANT® mm	Softwood material	Characteristic load bearing capacity and stiffness in softwood with KNAPP® screws 8 x 160 mm								
		$F_{1,KCC,Rk}$ kN	$F_{1,Rk}$ kN	$F_{2,KCC,Rk}$ kN	$F_{2,Rk}$ kN	$F_{3,Rk}$ kN	$F_{4KCC,Rk}$ kN	$F_{4,Rk}$ kN	$M_{tor,Rk}$ kNm	$K_{tor,ser}$ kNm/rad
310x100x40	C24	55,3	29,4	224,2 ¹⁾ *	115,3	44,5	62,4	41,2	4,2	346
	GL24h		31,7		124,5	46,2		43,2	4,4	391
430x100x40	C24		29,4	206,6 · f_{R2} ²⁾ *	192,2	58,2	68,6	68,7	8,6	1 066
	GL24h		31,7		207,4	60,6		72,0	9,2	1 206
550x100x40	C24		29,4		269,1*	72,0	74,9	96,1	14,9	2 443
	GL24h		31,7		290,4*	75,0		100,8	15,9	2 764

¹⁾ $F_{2,KCC,Rk}$ for torsional fixed header²⁾ $F_{2,KCC,Rk} \cdot f_{R2}$ for not torsional fixed header and f_{R2} according to page 44 ETA-15/0667 (16.08.2023)* $F_{t,Rk}$ = 226,1 kN (For MEGANT 550x100x40, the tensile strength of the threaded rods is critical!)

MEGANT® 150 series – Aluminium EN AW 6082

MEGANT® mm	Material	Characteristic load bearing capacity and stiffness in softwood with KNAPP® screws 8 x 160 mm								
		$F_{1,KCC,Rk}$ kN	$F_{1,Rk}$ kN	$F_{2,KCC,Rk}$ kN	$F_{2,Rk}$ kN	$F_{3,Rk}$ kN	$F_{4KCC,Rk}$ kN	$F_{4,Rk}$ kN	$M_{tor,Rk}$ kNm	$K_{tor,ser}$ kNm/rad
310x150x50	C24	74,3	39,8	375,0 ¹⁾	145	58,4	68,0	54,9	3,9	304
	GL24h		43,0		156	61,6		57,6	4,2	344
430x150x50	C24		39,8	366,5 · f_{R2} ²⁾	241	76,7	74,8	91,6	12,5	1 594
	GL24h		43,0		260	80,8		96,0	13,3	1 803
550x150x50	C24		39,8		337	95,0	81,6	128,2	20,9	3 488
	GL24h		43,0		364	100,0		134,4	22,3	3 946
610x150x50	C24		39,8		385	95,0		128,2	20,9	3 488
	GL24h		43,0		416	100,0		134,4	22,3	3 946
730x150x50	C24	39,8		482	95,0		128,2	20,9	3 488	
	GL24h	43,0		520	100,0		134,4	22,3	3 946	
1030x150x50 SL	C24	39,8	650	559	95,0		128,2	20,9	3 488	
	GL24h	43,0		604	100,0		134,4	22,3	3 946	

Possibility of using longer screws (8x240 mm), in end wood to increase the increase load capacity.

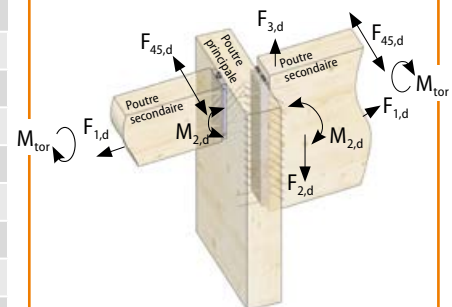

MEGANT®

Load bearing capacity values for MEGANT installed on hardwood, according to ETA-15/0667 (16.08.2023)

MEGANT® 60 series – Aluminium EN AW 6082

MEGANT® mm	Hardwood material	Characteristic load bearing capacity and stiffness in hardwood with ASSY PLUS VG screws 8 x 160 mm according to ETA-11/0190								
		F _{1,KCC,Rk} kN	F _{1,Rk} kN	F _{2,KCC,Rk} kN	F _{2,Rk} kN	F _{3,Rk} kN	F _{4KCC,Rk} kN	F _{4,Rk} kN	M _{tor,Rk} kNm	K _{tor,ser} kNm/rad
310x60x40	ρ _k = 530 kg/m ³	36,6	15,6	150,4 ¹⁾	96,3	43,3	36,9	33,0	3,5	374
	ρ _k = 590 kg/m ³		17,0		104,9	45,9		35,1	3,9	439
430x60x40	ρ _k = 530 kg/m ³		15,6	130,1 · f _{R2} ²⁾	151,3	59,1	40,6	51,9	7,5	1 241
	ρ _k = 590 kg/m ³		17,0		164,9	62,5		55,2	8,5	1 457
550x60x40	ρ _k = 530 kg/m ³		15,6		206,3	74,9	44,3	70,8	13,2	2 924
	ρ _k = 590 kg/m ³		17,0		224,8	79,2		75,3	14,9	3 434

F_{1,KCC,Rk}/F_{1,Rk} Characteristic load bearing capacity (aluminium failure/wood failure) in direction of secondary beam

F_{2,KCC,Rk}/F_{2,Rk} Characteristic load bearing capacity (aluminium failure/wood failure) in direction of insertion

F_{3,Rk} Characteristic load bearing capacity (wood failure) against direction of insertion

F_{4,KCC,Rk}/F_{4,Rk} Characteristic load bearing capacity (aluminium failure/wood failure) perpendicular to direction of insertion

M_{tor} Characteristic rotation moment

MEGANT® 100 series – Aluminium EN AW 6082

MEGANT® mm	Hardwood material	Characteristic load bearing capacity and stiffness in hardwood with ASSY PLUS VG screws 8 x 160 mm according to ETA-11/0190								
		F _{1,KCC,Rk} kN	F _{1,Rk} kN	F _{2,KCC,Rk} kN	F _{2,Rk} kN	F _{3,Rk} kN	F _{4KCC,Rk} kN	F _{4,Rk} kN	M _{tor,Rk} kNm	K _{tor,ser} kNm/rad
310x100x40	ρ _k = 530 kg/m ³	55,3	24,2	224,2 ^{1)*}	123,8	67,0	62,4	42,5	5,7	644
	ρ _k = 590 kg/m ³		26,4		134,9	70,9		45,2	6,4	757
430x100x40	ρ _k = 530 kg/m ³		24,2	206,6 · f _{R2} ^{2)*}	206,3	90,6	68,6	70,8	11,9	1 986
	ρ _k = 590 kg/m ³		26,4		224,8	95,9		75,3	13,3	2 333
550x100x40	ρ _k = 530 kg/m ³		24,2		288,9*	114,3	74,9	99,1	20,5	4 553
	ρ _k = 590 kg/m ³		26,4		314,8*	120,9		105,4	23,0	5 348

¹⁾ F_{2,KCC,Rk} for torsional fixed header

²⁾ F_{2,KCC,Rk} · f_{R2} for not torsional fixed header and f_{R2} according to page44 ETA-15/0667 (16.08.2023)

* F_{t,Rk} = 226,1 kN (For MEGANT 550x100x40, the tensile strength of the threaded rods is critical!)

MEGANT® 150 series – Aluminium EN AW 6082

MEGANT® mm	Hardwood material	Characteristic load bearing capacity and stiffness in hardwood with ASSY PLUS VG screws 8 x 160 mm according to ETA-11/0190								
		F _{1,KCC,Rk} kN	F _{1,Rk} kN	F _{2,KCC,Rk} kN	F _{2,Rk} kN	F _{3,Rk} kN	F _{4KCC,Rk} kN	F _{4,Rk} kN	M _{tor,Rk} kNm	K _{tor,ser} kNm/rad
310x150x50	ρ _k = 530 kg/m ³	74,3	32,8	375,0 ¹⁾	165,1	89,3	68,0	56,6	5,4	567
	ρ _k = 590 kg/m ³		35,8		179,9	94,6		60,2	6,1	666
430x150x50	ρ _k = 530 kg/m ³		32,8	366,5 · f _{R2} ²⁾	275,1	120,9	74,8	94,4	17,1	2 970
	ρ _k = 590 kg/m ³		35,8		299,8	127,9		100,4	19,2	3 489
550x150x50	ρ _k = 530 kg/m ³		32,8		385,2	152,4	81,6	132,1	28,7	6 500
	ρ _k = 590 kg/m ³		35,8		419,7	161,2		140,5	32,3	7 634
610x150x50	ρ _k = 530 kg/m ³		32,8		440,2	152,4		132,1	28,7	6 500
	ρ _k = 590 kg/m ³		35,8		479,6	161,2		140,5	32,3	7 634
730x150x50	ρ _k = 530 kg/m ³		32,8		550,3	152,4		132,1	28,7	6 500
	ρ _k = 590 kg/m ³		35,8		599,6	161,2		140,5	32,3	7 634
1030x150x50 SL	ρ _k = 530 kg/m ³		32,8	650	645,7	152,4		132,1	28,7	6 500
	ρ _k = 590 kg/m ³		35,8		703,5	161,2		140,5	32,3	7 634

A combination review of the different load directions shall be carried out in accordance with ETA-15/0667 (2023). In addition, consideration of the clamping moments M_{2,Rd} resulting from the torsion spring stiffness K_{2,φ} must be calculated in the design of the connection. For this purpose, instructions with the corresponding formula can be found in the European Technical Assessment ETA.

MEGANT®

(Dimensions in mm)

Assembly procedure



13:00 | After lifting and aligning the laminated beam, MEGANT® is put into position.



13:05 | Snap-fit: For threading and dropping, MEGANT® requires only 2 cm.



13:08 | Threaded rods inserted and screwed into the bottom jaw.



13:09 | Tighten hexagonal nuts.



13:11 | Connection completed.

MEGANT®

Fire protection

- Due to the concealed installation of the connectors on three or four sides, appropriate fire protection can be achieved via the corresponding timber cover.
- No additional covers or fire protection strips are required. According to EN 1995-1-2 point 3.4.3.1, but the joint can not exceed a maximum of 2 mm.
- If, due to manufacturing tolerances or for installation reasons, larger joints are required (2 - 10 mm), PROMASEAL intumescent sealant can be used. PROMASEAL®-PL* intumescent sealant can be used for protection. The flexible sealing strip is placed around the connector, expands and fills the gap in the event of fire, thus protecting the connector.
- According to EN 1995-1-2, 28 mm wood cover is required for fire rating of 30 min., 49 mm for 60 min., 70 mm for 90 min., and 120 minutes for 91 min (see calculation example on page 35).
- In special situations (e.g. due to non-compliance with the timber cover), the connector can be additionally protected against heat with a can be reduced with Promat PROMADUR®* clear fireproof paint. In the event of fire, the material expands and forms a protective insulating foam that delays combustion by 6 to 17 min (depending on the thickness of the paint) and allows smaller sections of wood to be used.

** For more information on the use and specification of fire protection materials please contact our research and development service.

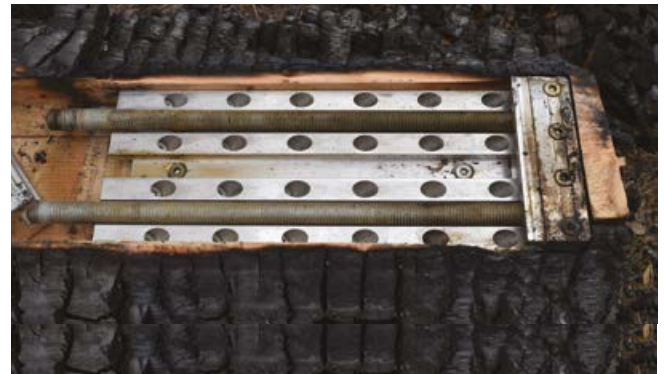

Fire test results after more than one hour. The section of wood is charred all around the connector. It guaranteed its integrity and its ability to withstand the force exerted.

PLANNER SERVICE

You have a project and want to use KNAPP® connectors?

Take advantage of our customized planning service.

KNAPP® offers a comprehensive planning and calculation service for all structural engineers, architects, and project managers.

We provide three benefits: an interactive load table, a dimensioning tool, and our calculation service by our in-house engineers.



* Our service does not replace an approval by a certified structural engineer in the country where the project is being carried out.



Strips of self-adhesive intumescent joint are laid around the connector and then stapled.

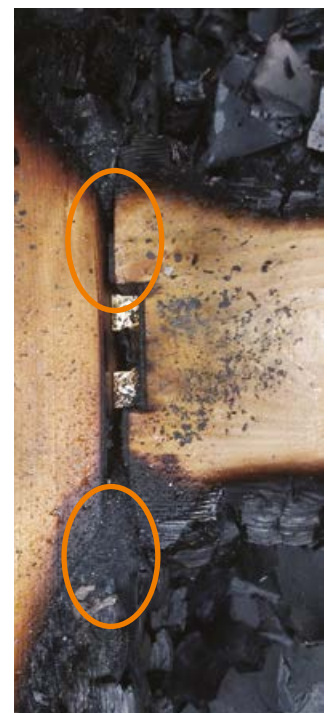

The 10 mm joint is closed by swelling intumescent seal, allowing the which allows the connector to be protected even after 120 min of fire.

MEGANT® 310/60/40

Technical details

Art.-No.K242

(Dimensions in mm)

MEGANT® 60 - load capacities with 8x160 screws, timber quality GL24h

MEGANT®	Min. secondary beam height [mm]	Characteristic values [kN]			
		max F _{1,Rk}	max F _{2,Rk}	max F _{3,Rk}	max F _{45,Rk}
L x L x H 310x60x40	L x H 100x440	20,4	96,8	29,1	33,6

The full range of resistance values can be found online on our website.

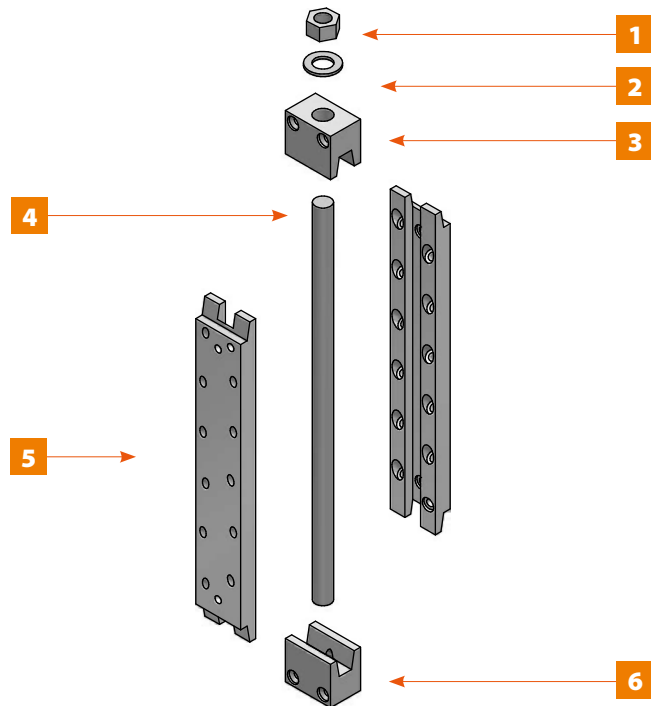
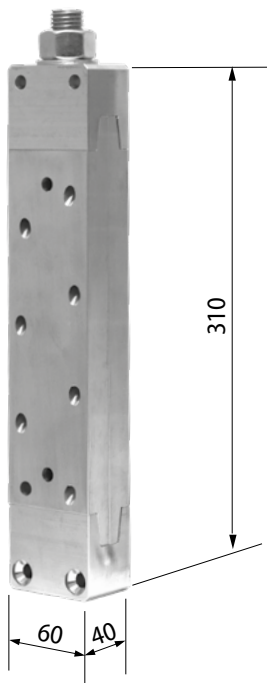

Pos.	Description	Pos.	Description
1	1 hexagonal nut M20	4	1 threaded rod M20x340
2	1 washer M20	5	2 connector plates 250x60x20
3	1 top clamping jaw (without thread) 60x50x40	6	1 bottom clamping jaw (with thread) 60x50x40

Vis MEGANT®

MEGANT® self-tapping CS-screw (corresponding CS-screws are included with MEGANT®)

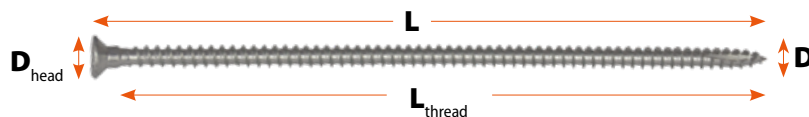

Art.-No.	Quantity	Type	D _{head}		L		L _{thread}		D		Bits
			mm	[inch]	mm	[inch]	mm	[inch]	mm	[inch]	
Z581	14	Angled CS screw	15	0.59	160	6.30	145	5.70	8	0.31	Torx 40
Z530	5	CS horizontal screws	15	0.59	240	9.45	225	8.86	8	0.31	Torx 40
Z581	5	CS horizontal screws	15	0.59	160	6.30	145	5.70	8	0.31	Torx 40

Screw connection on hardwood

Z670/Z675	24	ASSY CS screws for hardwoods	15	0.59	160	9.45	141	5.55	8	0.31	Torx 40
-----------	----	------------------------------	----	------	-----	------	-----	------	---	------	---------

Application: for positioning screws and diagonal screws as well as assembling the clamping jaw of the MEGANT®.

MEGANT® 430/60/40

Technical details

Art.-No.K243

(Dimensions in mm)

MEGANT® 60 - load capacities with 8x160 screws, timber quality GL24h

MEGANT®	Min. secondary beam height [mm]	Characteristic values [kN]			
		max F _{1,Rk}	max F _{2,Rk}	max F _{3,Rk}	max F _{45,Rk}
430x60x40	100x520	20,4	152,1	38,7	40,6

The full range of resistance values can be found online on our website.

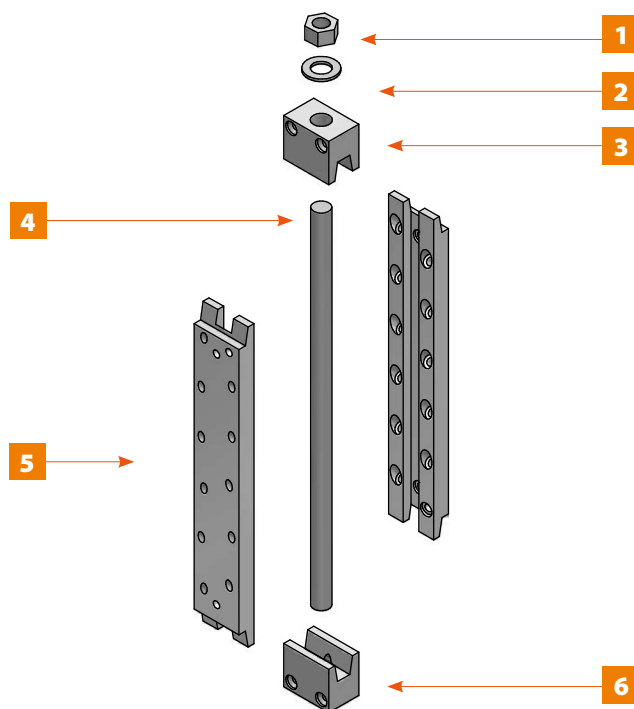
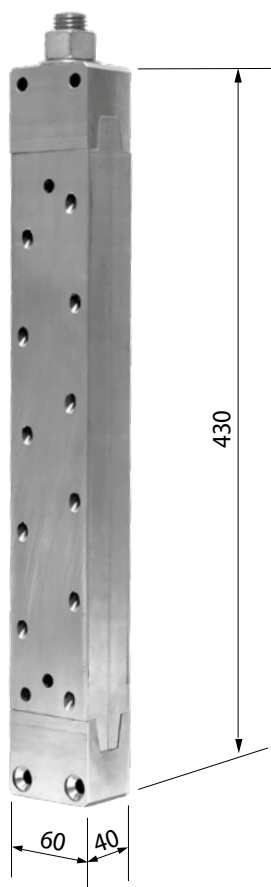

Pos.	Description	Pos.	Description
1	1 hexagonal nut M20	4	1 threaded rod M20x340
2	1 washer M20	5	2 connector plates 370x60x20
3	1 top clamping jaw (without thread) 60x50x40	6	1 bottom clamping jaw (with thread) 60x50x40

Vis MEGANT®

MEGANT® self-tapping CS-screw (corresponding CS-screws are included with MEGANT®)

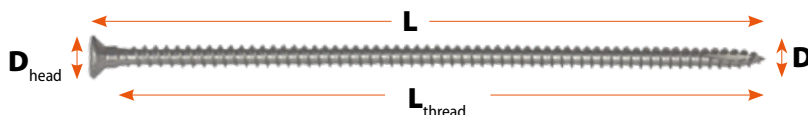

Art.-No.	Quantity	Type	D _{head}		L		L _{thread}		D		Bits
			mm	[inch]	mm	[inch]	mm	[inch]	mm	[inch]	
Z581	22	Angled CS screw	15	0.59	160	6.30	145	5.70	8	0.31	Torx 40
Z530	5	CS horizontal screws	15	0.59	240	9.45	225	8.86	8	0.31	Torx 40
Z581	5	CS horizontal screws	15	0.59	160	6.30	145	5.70	8	0.31	Torx 40

Screw connection on hardwood

Z670/Z675	32	ASSY CS screws for hardwoods	15	0.59	160	9.45	141	5.55	8	0.31	Torx 40
-----------	----	------------------------------	----	------	-----	------	-----	------	---	------	---------

Application: for positioning screws and diagonal screws as well as assembling the clamping jaw of the MEGANT®.

MEGANT® 550/60/40

Technical details

Art.-No.K244

(Dimensions in mm)

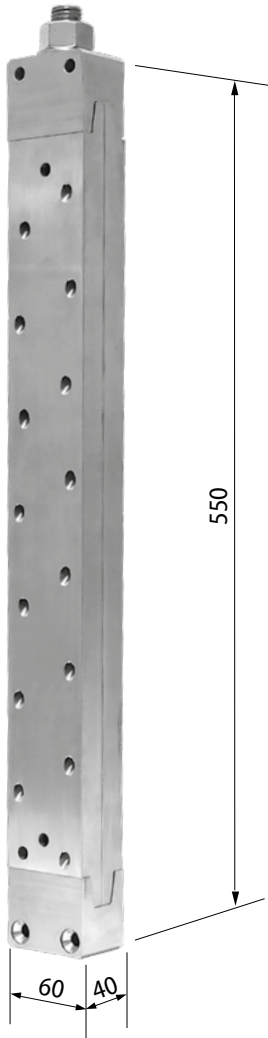

MEGANT® 60 - load capacities with 8x160 screws, timber quality GL24h

MEGANT®	Min. secondary beam height [mm]	Characteristic values [kN]			
		max F _{1,Rk}	max F _{2,Rk}	max F _{3,Rk}	max F _{45,Rk}
550x60x40	100x640	20,4	177,7	48,3	44,3

The full range of resistance values can be found online on our website.

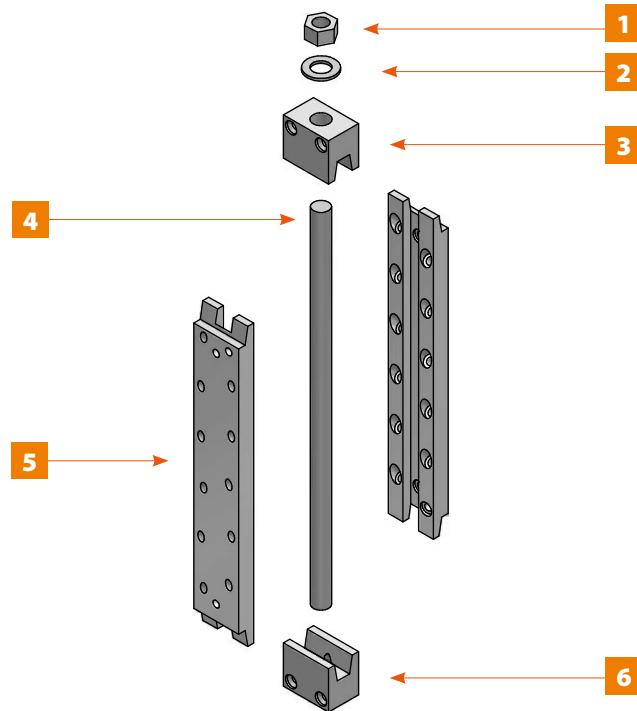

Pos.	Description	Pos.	Description
1	1 hexagonal nut M20	4	1 threaded rod M20x580
2	1 washer M20	5	2 connector plates 490x60x20
3	1 top clamping jaw (without thread) 60x50x40	6	1 bottom clamping jaw (with thread) 60x50x40

Vis MEGANT®

MEGANT® self-tapping CS-screw (corresponding CS-screws are included with MEGANT®)

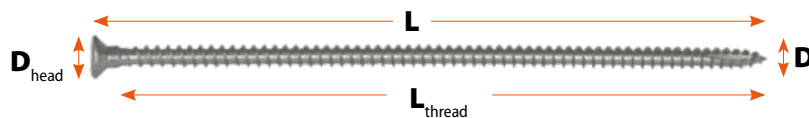

Art.-No.	Quantity	Type	D _{head}		L		L _{thread}		D		Bits
			mm	[inch]	mm	[inch]	mm	[inch]	mm	[inch]	
Z581	30	Angled CS screw	15	0.59	160	6.30	145	5.70	8	0.31	Torx 40
Z530	5	CS horizontal screws	15	0.59	240	9.45	225	8.86	8	0.31	Torx 40
Z581	5	CS horizontal screws	15	0.59	160	6.30	145	5.70	8	0.31	Torx 40

Screw connection on hardwood

Z670/Z675	40	ASSY CS screws for hardwoods	15	0.59	160	9.45	141	5.55	8	0.31	Torx 40
-----------	----	------------------------------	----	------	-----	------	-----	------	---	------	---------

Application: for positioning screws and diagonal screws as well as assembling the clamping jaw of the MEGANT®.

MEGANT® 310/100/40

Technical details

Art.-No.K239

(Dimensions in mm)

MEGANT® 100 - load capacities with 8x160 screws, timber quality GL24h

MEGANT®	Min. secondary beam height [mm]	Characteristic values [kN]			
		max F _{1,Rk}	max F _{2,Rk}	max F _{3,Rk}	max F _{45,Rk}
310x100x40	140x440	31,7	124,5	46,2	43,2

The full range of resistance values can be found online on our website.

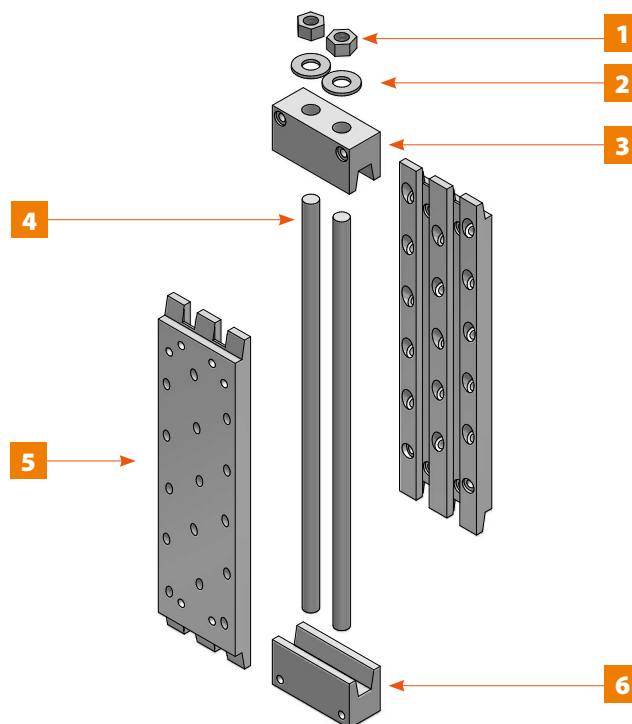
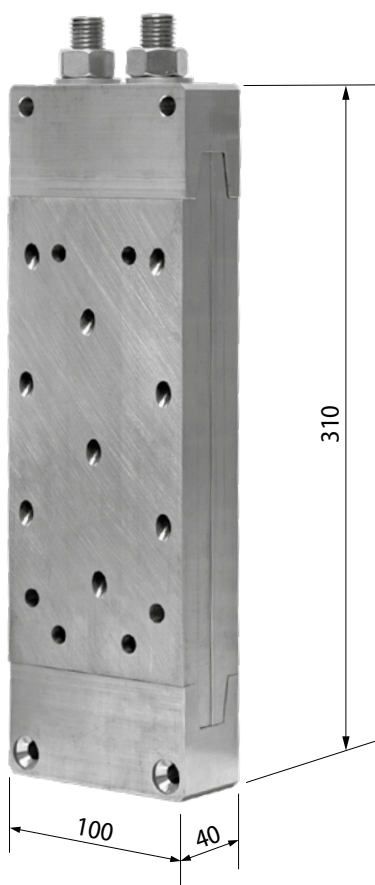

Pos.	Description	Pos.	Description
1	2 hexagonal nuts M16	4	2 threaded rods M16x340
2	2 washers M16	5	2 connector plates 250x100x20
3	1 top clamping jaw (without thread) 100x50x40	6	1 bottom clamping jaw (with thread) 100x50x40

Vis MEGANT®

MEGANT® self-tapping CS-screw (corresponding CS-screws are included with MEGANT®)

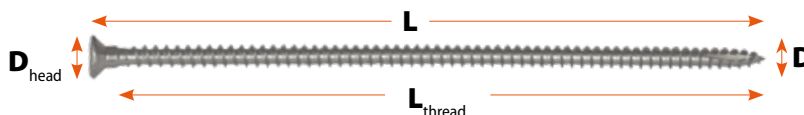

Art.-No.	Quantity	Type	D _{head}		L		L _{thread}		D		Bits
			mm	[inch]	mm	[inch]	mm	[inch]	mm	[inch]	
Z581	18	Angled CS screw	15	0.59	160	6.30	145	5.70	8	0.31	Torx 40
Z530	6	CS horizontal screws	15	0.59	240	9.45	225	8.86	8	0.31	Torx 40
Z581	10	CS horizontal screws	15	0.59	160	6.30	145	5.70	8	0.31	Torx 40

Screw connection on hardwood

Z670/Z675	34	ASSY CS screws for hardwoods	15	0.59	160	9.45	141	5.55	8	0.31	Torx 40
-----------	----	------------------------------	----	------	-----	------	-----	------	---	------	---------

Application: for positioning screws and diagonal screws as well as assembling the clamping jaw of the MEGANT®.

MEGANT® 430/100/40

Technical details

Art.-No.K240

(Dimensions in mm)

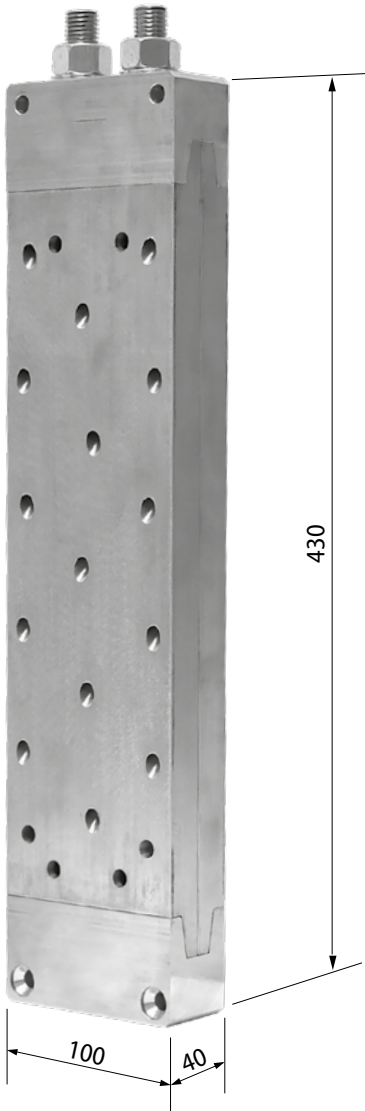

MEGANT® 100 - load capacities with 8x160 screws, timber quality GL24h

MEGANT®	Min. secondary beam height [mm]	Characteristic values [kN]			
		max F _{1,Rk}	max F _{2,Rk}	max F _{3,Rk}	max F _{45,Rk}
430x100x40	140x520	31,7	207,4	60,6	68,6

The full range of resistance values can be found online on our website.

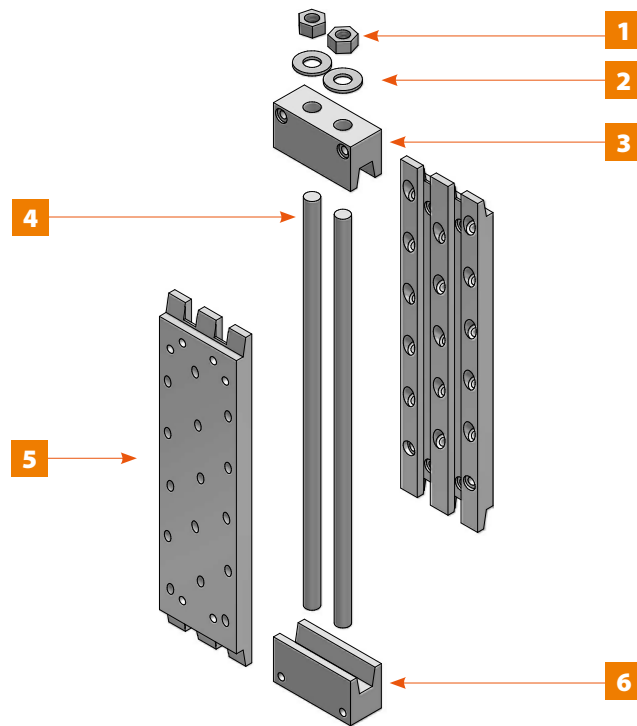

Pos.	Description	Pos.	Description
1	2 hexagonal nuts M16	4	2 threaded rods M16x460
2	2 washers M16	5	2 connector plates 370x100x20
3	1 top clamping jaw (without thread) 100x50x40	6	1 bottom clamping jaw (with thread) 100x50x40

Vis MEGANT®

MEGANT® self-tapping CS-screw (corresponding CS-screws are included with MEGANT®)

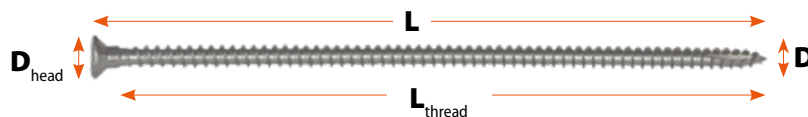

Art.-No.	Quantity	Type	D _{head}		L		L _{thread}		D		Bits
			mm	[inch]	mm	[inch]	mm	[inch]	mm	[inch]	
Z581	30	Angled CS screw	15	0.59	160	6.30	145	5.70	8	0.31	Torx 40
Z530	6	CS horizontal screws	15	0.59	240	9.45	225	8.86	8	0.31	Torx 40
Z581	10	CS horizontal screws	15	0.59	160	6.30	145	5.70	8	0.31	Torx 40

Screw connection on hardwood

Z670/Z675	46	ASSY CS screws for hardwoods	15	0.59	160	9.45	141	5.55	8	0.31	Torx 40
-----------	----	------------------------------	----	------	-----	------	-----	------	---	------	---------

Application: for positioning screws and diagonal screws as well as assembling the clamping jaw of the MEGANT®.

MEGANT® 550/100/40

Technical details

Art.-No.K241

(Dimensions in mm)

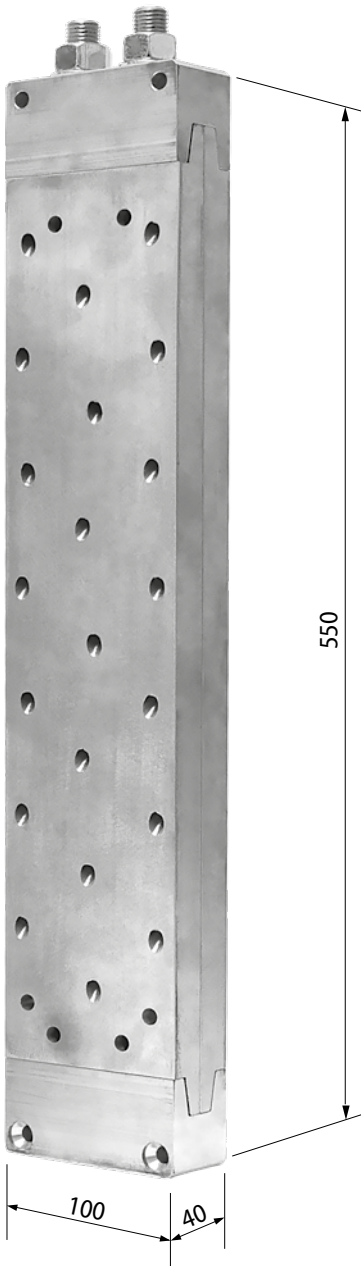

MEGANT® 100 - load capacities with 8x160 screws, timber quality GL24h

MEGANT®	Min. secondary beam height [mm]	Characteristic values [kN]			
		max F _{1,Rk}	max F _{2,Rk}	max F _{3,Rk}	max F _{45,Rk}
550x100x40	140x640	31,7	235,2	75,0	74,9

The full range of resistance values can be found online on our website.

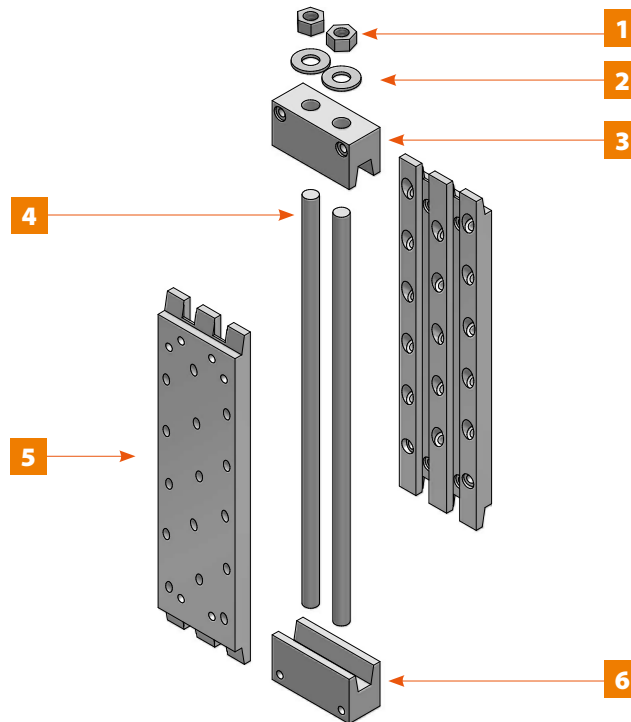

Pos.	Description	Pos.	Description
1	2 hexagonal nuts M16	4	2 threaded rods M16x580
2	2 washers M16	5	2 connector plates 490x100x20
3	1 top clamping jaw (without thread) 100x50x40	6	1 bottom clamping jaw (with thread) 100x50x40

Vis MEGANT®

MEGANT® self-tapping CS-screw (corresponding CS-screws are included with MEGANT®)

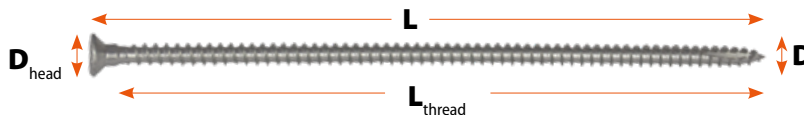

Art.-No.	Quantity	Type	D _{head}		L		L _{thread}		D		Bits
			mm	[inch]	mm	[inch]	mm	[inch]	mm	[inch]	
Z581	42	Angled CS screw	15	0.59	160	6.30	145	5.70	8	0.31	Torx 40
Z530	6	CS horizontal screws	15	0.59	240	9.45	225	8.86	8	0.31	Torx 40
Z581	10	CS horizontal screws	15	0.59	160	6.30	145	5.70	8	0.31	Torx 40

Screw connection on hardwood

Z670/Z675	58	ASSY CS screws for hardwoods	15	0.59	160	9.45	141	5.55	8	0.31	Torx 40
-----------	----	------------------------------	----	------	-----	------	-----	------	---	------	---------

Application: for positioning screws and diagonal screws as well as assembling the clamping jaw of the MEGANT®.

MEGANT® 310/150/50

Technical details

Art.-No.K197

(Dimensions in mm)

MEGANT® 150 - load capacities with 8x160 screws, timber quality GL24h

MEGANT®	Min. secondary beam height [mm]	Characteristic values [kN]			
		max F _{1,Rk}	max F _{2,Rk}	max F _{3,Rk}	max F _{45,Rk}
310x150x50	190x440	43,0	156,0	61,6	57,6

The full range of resistance values can be found online on our website.

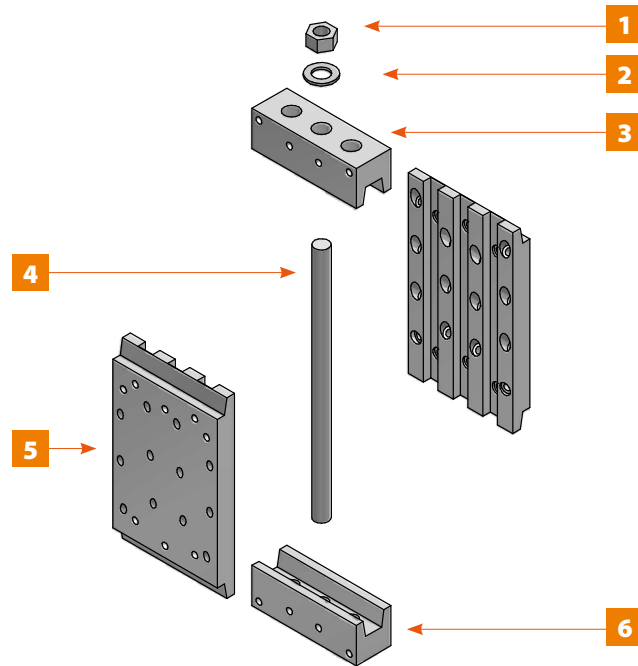
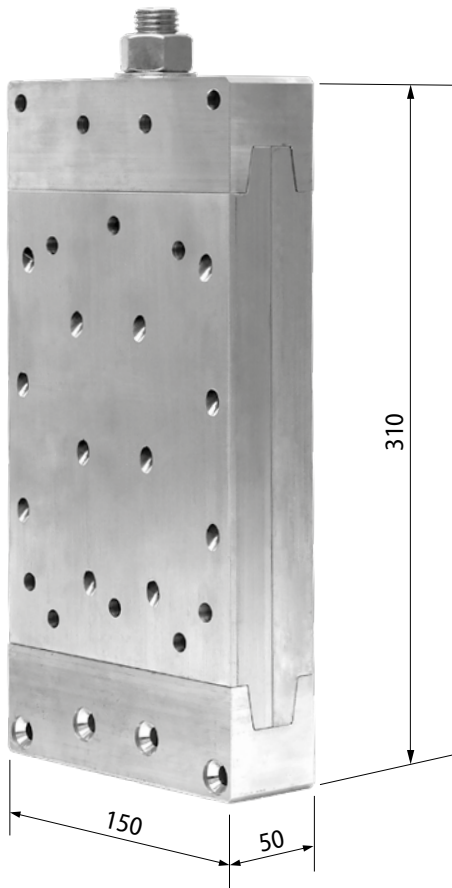

Pos.	Description	Pos.	Description
1	1-2 hexagonal nut(s) M20	4	1-2 threaded rods M20x340
2	1-2 washers M20	5	2 connector plates 250x150x25
3	1 top clamping jaw (without thread) 150x50x50	6	1 bottom clamping jaw (with thread) 150x50x50

Vis MEGANT®

MEGANT® self-tapping CS-screw (corresponding CS-screws are included with MEGANT®)

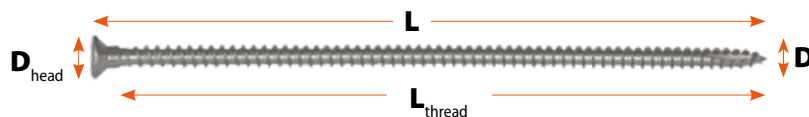

Art.-No.	Quantity	Type	D _{head}		L		L _{thread}		D		Bits
			mm	[inch]	mm	[inch]	mm	[inch]	mm	[inch]	
Z581	24	Angled CS screw	15	0.59	160	6.30	145	5.70	8	0.31	Torx 40
Z530	12	CS horizontal screws	15	0.59	240	9.45	225	8.86	8	0.31	Torx 40
Z581	12	CS horizontal screws	15	0.59	160	6.30	145	5.70	8	0.31	Torx 40

Screw connection on hardwood

Z670/Z675	48	ASSY CS screws for hardwoods	15	0.59	160	9.45	141	5.55	8	0.31	Torx 40
-----------	----	------------------------------	----	------	-----	------	-----	------	---	------	---------

Application: for positioning screws and diagonal screws as well as assembling the clamping jaw of the MEGANT®.

MEGANT® 430/150/50

Technical details

Art.-No.K220

(Dimensions in mm)

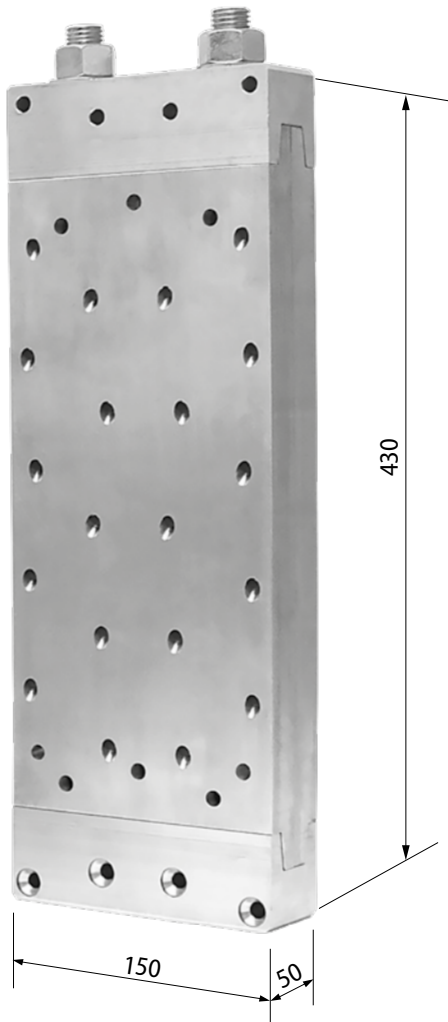

MEGANT® 150 - load capacities with 8x160 screws, timber quality GL24h

MEGANT®	Min. secondary beam height [mm]	Characteristic values [kN]			
		max F _{1,Rk}	max F _{2,Rk}	max F _{3,Rk}	max F _{45,Rk}
430x150x50	190x520	43,0	260,0	80,8	74,8

The full range of resistance values can be found online on our website.

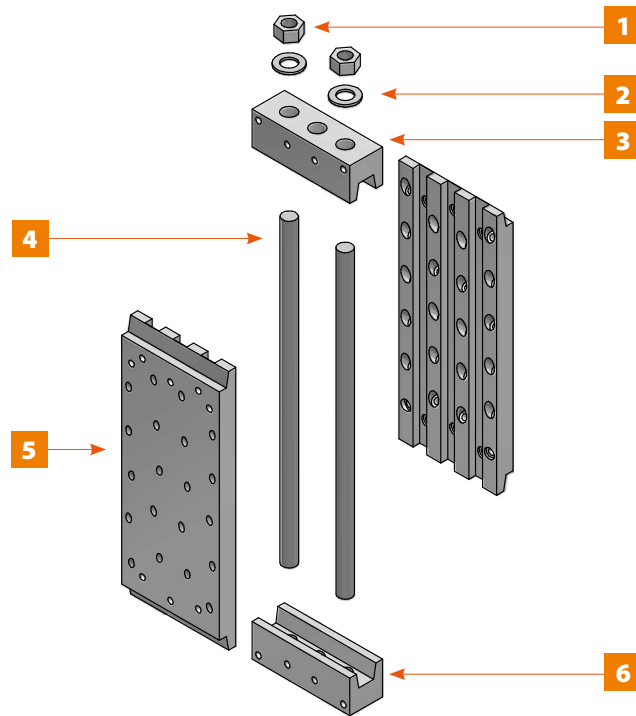

Pos.	Description	Pos.	Description
1	2-3 hexagonal nuts M20	4	2-3 threaded rods M20x460
2	2-3 washers M20	5	2 connector plates 370x150x25
3	1 top clamping jaw (without thread) 150x50x50	6	1 bottom clamping jaw (with thread) 150x50x50

Vis MEGANT®

MEGANT® self-tapping CS-screw (corresponding CS-screws are included with MEGANT®)

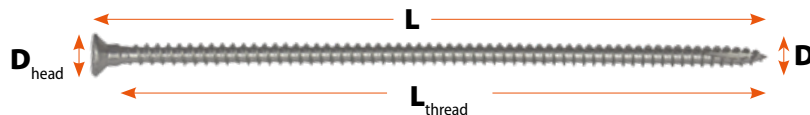

Art.-No.	Quantity	Type	D _{head}		L		L _{thread}		D		Bits
			mm	[inch]	mm	[inch]	mm	[inch]	mm	[inch]	
Z581	40	Angled CS screw	15	0.59	160	6.30	145	5.70	8	0.31	Torx 40
Z530	12	CS horizontal screws	15	0.59	240	9.45	225	8.86	8	0.31	Torx 40
Z581	12	CS horizontal screws	15	0.59	160	6.30	145	5.70	8	0.31	Torx 40

Screw connection on hardwood

Z670/Z675	64	ASSY CS screws for hardwoods	15	0.59	160	9.45	141	5.55	8	0.31	Torx 40
-----------	----	------------------------------	----	------	-----	------	-----	------	---	------	---------

Application: for positioning screws and diagonal screws as well as assembling the clamping jaw of the MEGANT®.

MEGANT® 550/150/50

Technical details

Art.-No.K221

(Dimensions in mm)

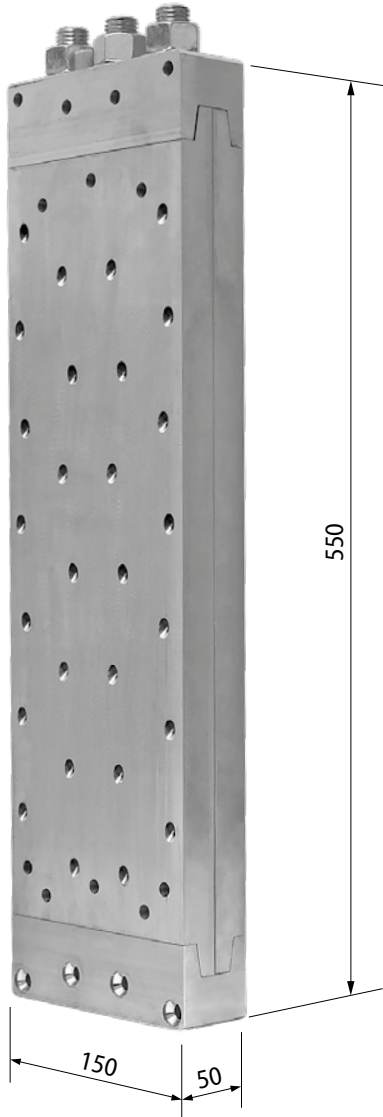

MEGANT® 150 - load capacities with 8x160 screws, timber quality GL24h

MEGANT®	Min. secondary beam height [mm]	Characteristic values [kN]			
		max F _{1,Rk}	max F _{2,Rk}	max F _{3,Rk}	max F _{45,Rk}
550x150x50	190x640	43,0	364,0	100,0	81,6

The full range of resistance values can be found online on our website.

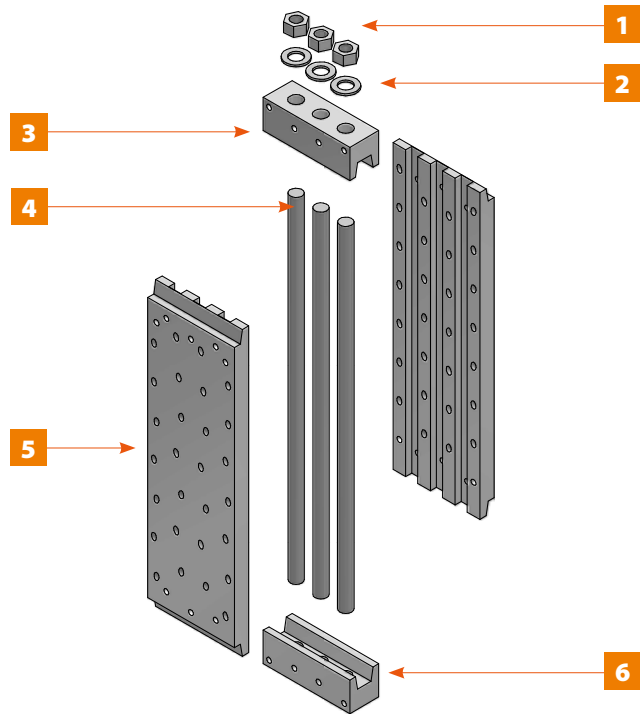

Pos.	Description	Pos.	Description
1	3 hexagonal nuts M20	4	3 threaded rods M20x580
2	3 washers M20	5	2 connector plates 490x150x25
3	1 top clamping jaw (without thread) 150x50x50	6	1 bottom clamping jaw (with thread) 150x50x50

Vis MEGANT®

MEGANT® self-tapping CS-screw (corresponding CS-screws are included with MEGANT®)

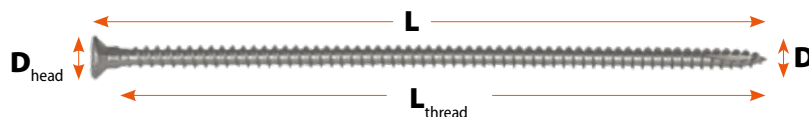

Art.-No.	Quantity	Type	D _{head}		L		L _{thread}		D		Bits
			mm	[inch]	mm	[inch]	mm	[inch]	mm	[inch]	
Z581	56	Angled CS screw	15	0.59	160	6.30	145	5.70	8	0.31	Torx 40
Z530	12	CS horizontal screws	15	0.59	240	9.45	225	8.86	8	0.31	Torx 40
Z581	12	CS horizontal screws	15	0.59	160	6.30	145	5.70	8	0.31	Torx 40

Screw connection on hardwood

Z670/Z675	80	ASSY CS screws for hardwoods	15	0.59	160	9.45	141	5.55	8	0.31	Torx 40
-----------	----	------------------------------	----	------	-----	------	-----	------	---	------	---------

Application: for positioning screws and diagonal screws as well as assembling the clamping jaw of the MEGANT®.

MEGANT® 610/150/50

Technical details

Art.-No. K180

(Dimensions in mm)

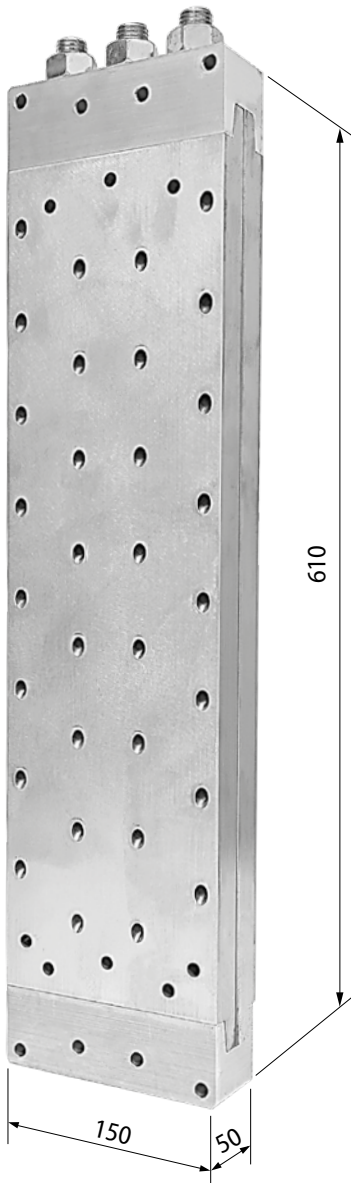

MEGANT® 150 load capacities with 8x160 screws, timber quality GL24h

MEGANT®	Min. secondary beam height [mm]	Characteristic values [kN]			
		max F _{1,Rk}	max F _{2,Rk}	max F _{3,Rk}	max F _{45,Rk}
610x150x50	190x710	43,0	416	100,0	81,6

The full range of resistance values can be found online on our website.

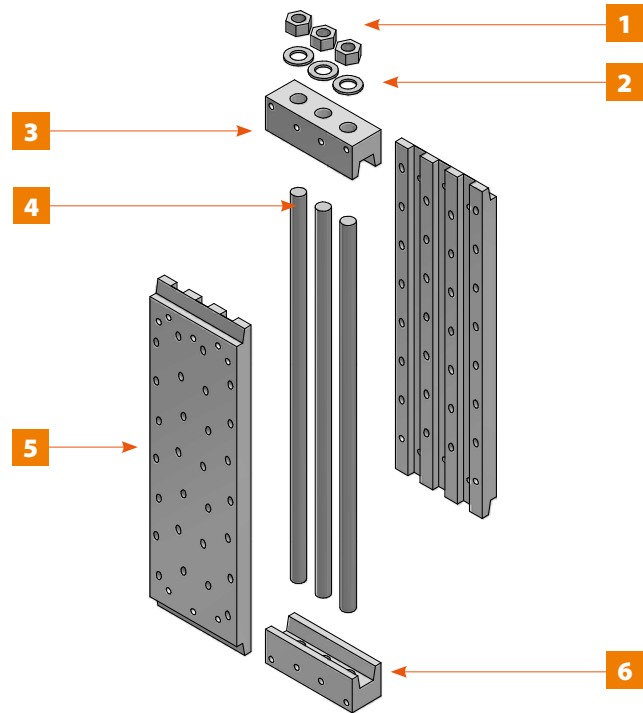

Pos.	Description	Pos.	Description
1	3 hexagonal nuts M20	4	3 threaded rods M20x640
2	3 washers M 20	5	2 connector plates 550x150x25
3	1 top clamping jaw (without thread) 150x50x50	6	1 bottom clamping jaw (with thread) 150x50x50

MEGANT® screws

MEGANT® self-tapping CS-screw (corresponding CS-screws are included with MEGANT®)

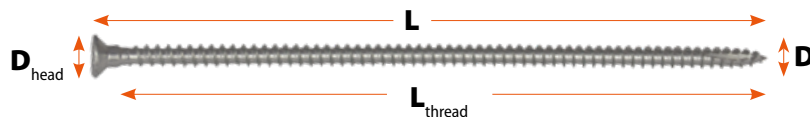

Art.-No.	Quantity	Type	D _{head}		L		L _{thread}		D		Bits
			mm	[inch]	mm	[inch]	mm	[inch]	mm	[inch]	
Z581	64	Angled CS screw	15	0.59	160	6.30	145	5.70	8	0.31	Torx 40
Z530	12	CS horizontal screws	15	0.59	240	9.45	225	8.86	8	0.31	Torx 40
Z581	12	CS horizontal screws	15	0.59	160	6.30	145	5.70	8	0.31	Torx 40

Screw connection on hardwood

Z670/Z675	88	ASSY CS screws for hardwoods	15	0.59	160	6.30	141	5.55	8	0.31	Torx 40
-----------	----	------------------------------	----	------	-----	------	-----	------	---	------	---------

Application: for positioning screws and diagonal screws as well as assembling the clamping jaw of the MEGANT®.

MEGANT® 730/150/50

Technical details

Art.-No.K251

(Dimensions in mm)

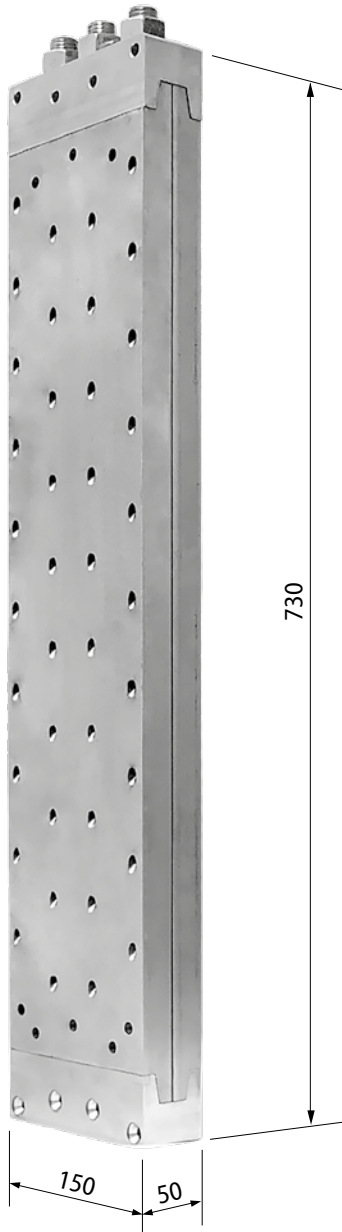

MEGANT® 150 - load capacities with 8x160 screws, timber quality GL24h

MEGANT®	Min. secondary beam height [mm]	Characteristic values [kN]			
		max F _{1,Rk}	max F _{2,Rk}	max F _{3,Rk}	max F _{45,Rk}
730x150x50	190x830	43,0	443,2	100,0	81,6

The full range of resistance values can be found online on our website.

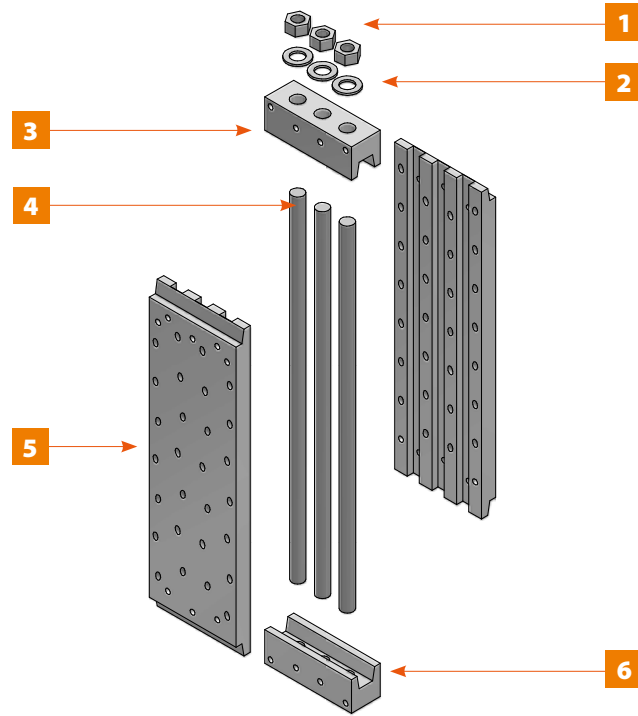

Pos.	Description	Pos.	Description
1	3 hexagonal nuts M20	4	3 threaded rods M20x760
2	3 washers M20	5	2 connector plates 670x150x25
3	1 top clamping jaw (without thread) 150x50x50	6	1 bottom clamping jaw (with thread) 150x50x50

Vis MEGANT®

MEGANT® self-tapping CS-screw (corresponding CS-screws are included with MEGANT®)

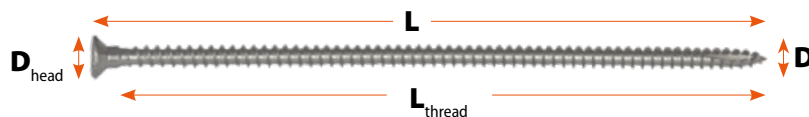

Art.-No.	Quantity	Type	D _{head}		L		L _{thread}		D		Bits
			mm	[inch]	mm	[inch]	mm	[inch]	mm	[inch]	
Z581	80	Angled CS screw	15	0.59	160	6.30	145	5.70	8	0.31	Torx 40
Z530	12	CS horizontal screws	15	0.59	240	9.45	225	8.86	8	0.31	Torx 40
Z581	12	CS horizontal screws	15	0.59	160	6.30	145	5.70	8	0.31	Torx 40

Screw connection on hardwood

Z670/Z675	104	ASSY CS screws for hardwoods	15	0.59	160	9.45	141	5.55	8	0.31	Torx 40
-----------	-----	------------------------------	----	------	-----	------	-----	------	---	------	---------

Application: for positioning screws and diagonal screws as well as assembling the clamping jaw of the MEGANT®.

MEGANT® 1030/150/50 SL

Technical details

Art.-No.K180

(Dimensions in mm)

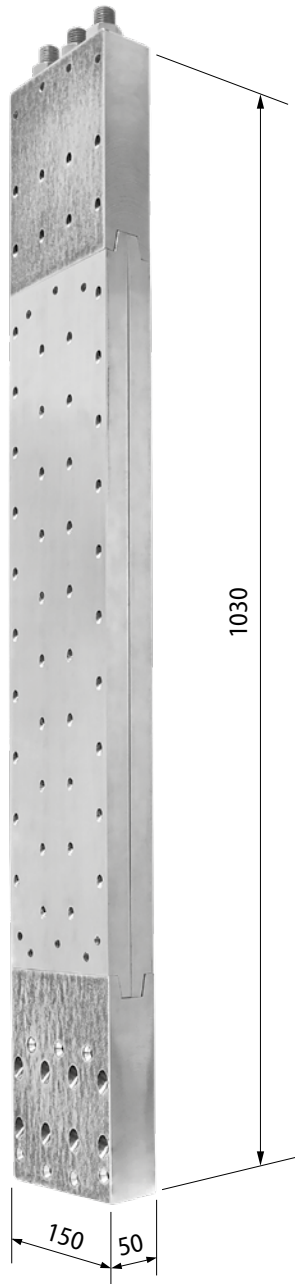

MEGANT® 150 - load capacities with 8x160 screws, timber quality GL24h

MEGANT®	Min. secondary beam height [mm]	Characteristic values [kN]			
		max F _{1,Rk}	max F _{2,Rk}	max F _{3,Rk}	max F _{45,Rk}
1030x150x50 SL*	190x1130	43,0	604,0*	100,0	81,6
1030x150x50 SL**	190x1130	43,0	768,0**	100,0	81,6

* MEGANT® 1030x150x50, calculated with angled screws 8x160 and horizontal screws 8x240/8x160 on GL24h

** MEGANT® 1030x150x50, calculated with 8x240 slant screws and 8x240/8x160 horizontal screws on GL24h

The full range of resistance values can be found online on our website.

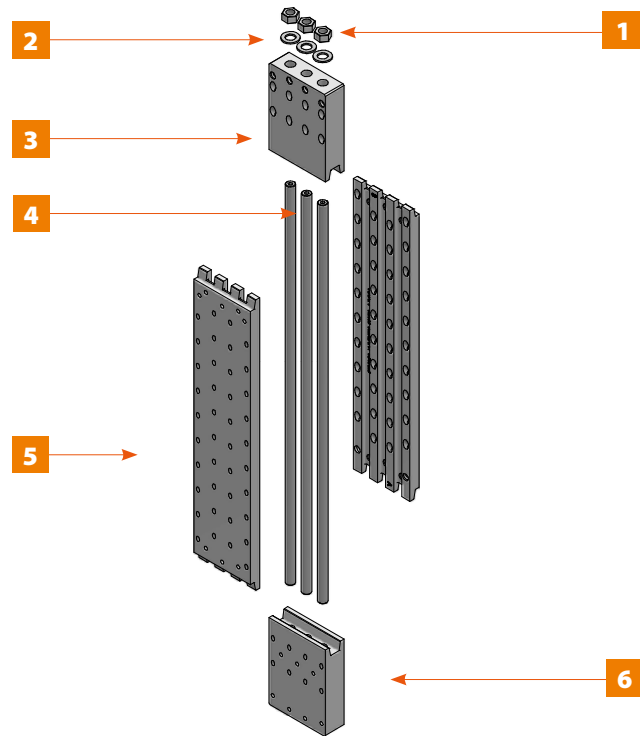

Pos.	Description	Pos.	Description
1	3 hexagonal nuts M20	4	3 threaded rods M20x920
2	3 washers M20	5	2 connector plates 670x150x25
3	1 top clamping jaw (without thread) 150x200x50	6	1 bottom clamping jaw (with thread) 150x200x50

Vis MEGANT®

MEGANT® self-tapping CS-screw (corresponding CS-screws are included with MEGANT®)

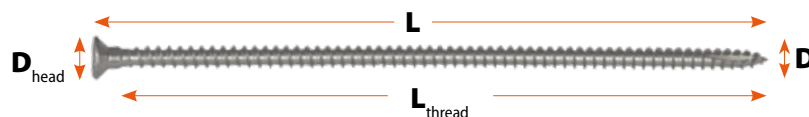

Art.-No.	Quantity	Type	D _{head}		L		L _{thread}		D		Bits
			mm	[inch]	mm	[inch]	mm	[inch]	mm	[inch]	
Z581	96	Angled CS screw	15	0.59	160	6.30	145	5.70	8	0.31	Torx 40
Z530	12	CS horizontal screws	15	0.59	240	9.45	225	8.86	8	0.31	Torx 40
Z581	15	CS horizontal screws	15	0.59	160	6.30	145	5.70	8	0.31	Torx 40

Screw connection on hardwood

Z670/Z675	123	ASSY CS screws for hardwoods	15	0.59	160	9.45	141	5.55	8	0.31	Torx 40
-----------	-----	------------------------------	----	------	-----	------	-----	------	---	------	---------

Application: for positioning screws and diagonal screws as well as assembling the clamping jaw of the MEGANT®.

Timber wall connector

Connecting timber frame constructions up to 10,8 kN*

- | Timber width from 60 mm
- | High level of prefabrication
- | Simple and easy – the wall panels are plugged together,
- | Self-tightening, stable and invisible – the structure is stable from the first corner onwards
- | Wood frame and plywood board walls frictionally interconnected

Available in 2 sizes.

Design values are available on our website under Planer Service.

* Characteristic value $F_{2,Rk}$ in slide-in direction, valid only with the use of original KNAPP® CS screws 10x60 mm, on C24 according to ETA 10/0189 (2022/08/25).

WALCO® Z



Ausbildungszentrum Bühl © Isocell

WALCO® Z40

- Applications: concealed wall connectors in timber frame and wood panels
- Connections: solid woods, derived timber products e.g. CLT
- Areas of application: timber frame and timber panel construction, and CLT walls, and buildings
- Service class 1 and 2

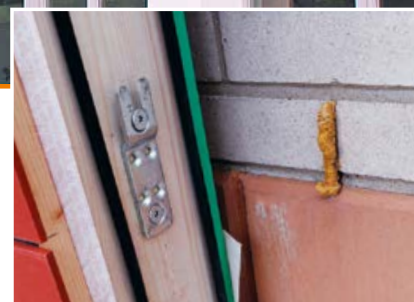

Installation example: WALCO® Z40 mounted on the wall with double-sided element seals.

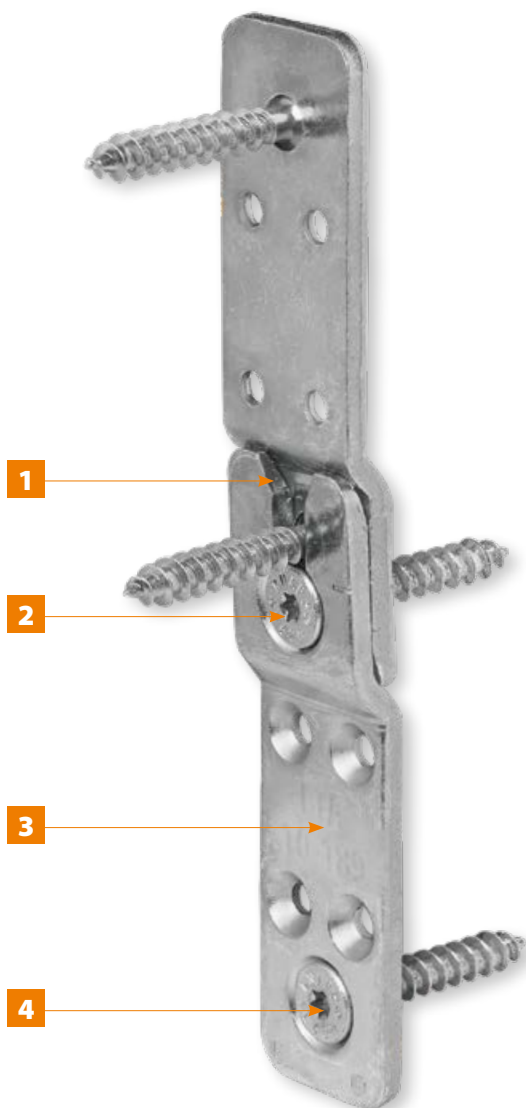

- 1 The stop bevels and the guiding slot for the KNAPP® CS retaining screws bring the connector parts into position and on tension.
- 2 The KNAPP® CS-retaining screw allows for adjustments to the compression of joints.
- 3 WALCO® Z40 consists of two identical connector parts and is made of high quality steel in Austria.
- 4 The Ø 10 mm CS-screws with integrated drilling tip enable rapid fastening with screws; the reinforced shaft provides friction-locked connection.

Fire rating: Fire resistance (EN 1995-1-2) through 3-4 sided concealed, joint-tight installation (R30 ≥ 28 mm, R60 ≥ 49 mm)



WALCO® Z40

Application examples and connection details

Timber frame construction

(Dimensions in mm)

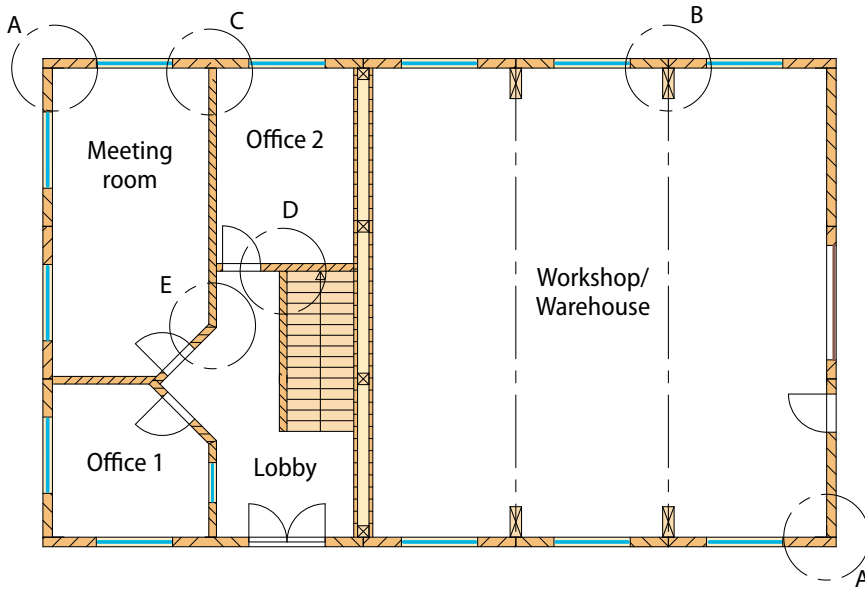

Detail A₁:
Timber frame
exterior wall
corner

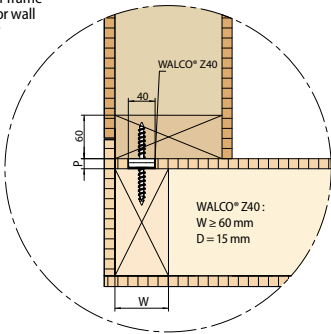

Detail A₂:
Timber frame
exterior wall
corner

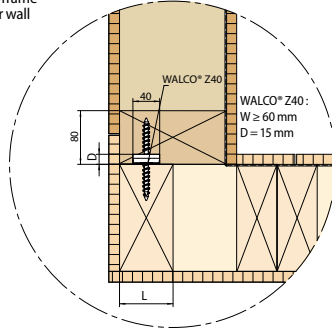

Detail B:
Timber frame
exterior wall
column
connection

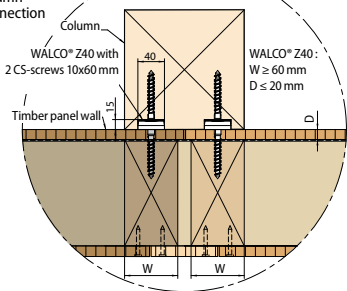

Detail C:
Timber frame
exterior and
interior wall
connection

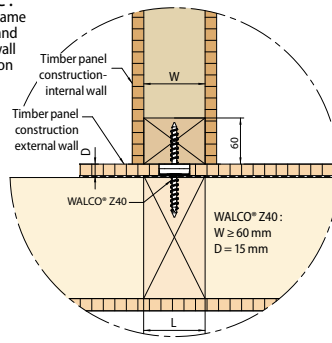

Detail D:
Timber frame
interior wall
connection

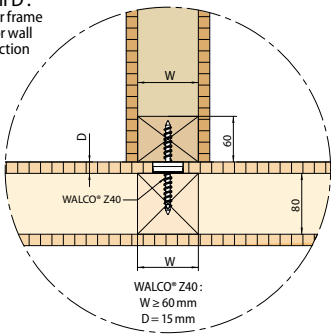

Detail E:
Timber frame
wall mitre
connection

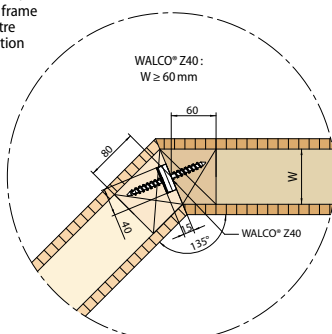

Precast walls with CLT walls

Detail A₃:
CLT exterior
wall corner

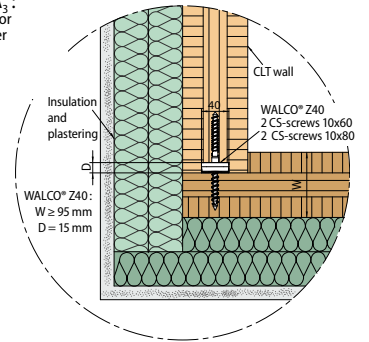

Detail C:
CLT exterior and
interior wall
connection

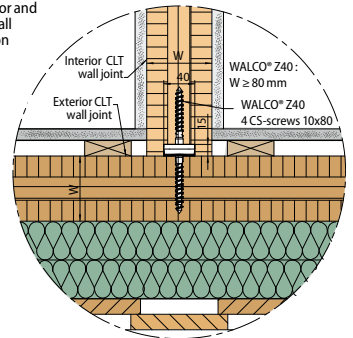

Detail E:
CLT wall mitre
connection

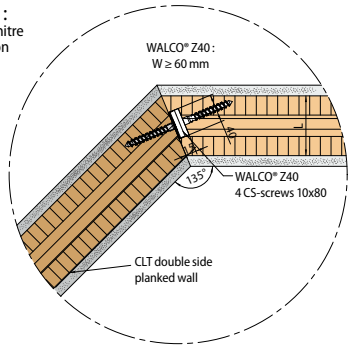

Detail B:
CLT exterior wall
column
connection

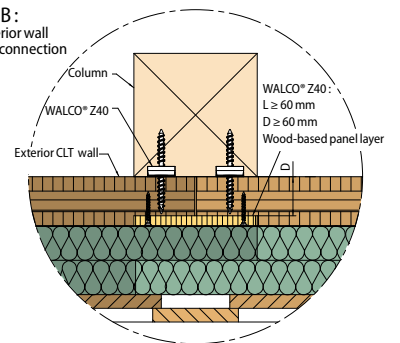

Detail D:
CLT interior
wall connection

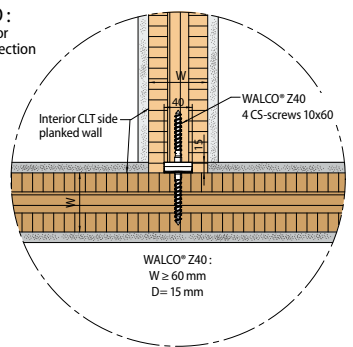

WALCO® Z40

WALCO® Z40 - Partial screw connection

Art.-No. K072

(Dimensions in mm)



Screw connection	
Wall 1	Wall 2
2x CS 10x60 mm	2x CS 10x60 mm

Full screw connection :
8x 6 x 50 mm

Minimum timber cross section:
L. x Ep. = 60 x 60 mm

WALCO® Z40 - Full screw connection

Art.-No. K072

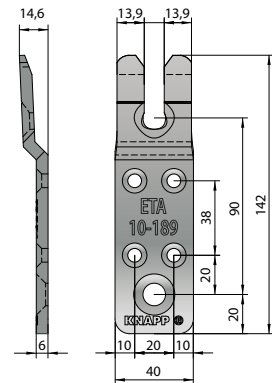

Tensile values*

Characteristic tensile values $F_{1,Rk}$ [kN] for timber grade C24 and above

Connector	Minimum timber cross section [mm]	No interlayer		OSB ≤ 22 mm**		Plasterboard ≤ 22 mm***	
		Partial screw connection	Full screw connection	Partial screw connection	Full screw connection	Partial screw connection	Full screw connection
WALCO® Z40	Internal wall : 60x60 External wall : 100x60	4,73	4,73	4,73	4,73	4,73	4,73

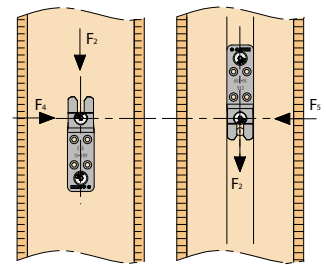
Characteristic shear values in the direction of insertion $F_{2,Rk}$ [kN] for timber grade C24 and above

Connector	Minimum timber cross section [mm]	No interlayer		OSB ≤ 22 mm**		Plasterboard ≤ 22 mm***	
		Partial screw connection	Full screw connection	Partial screw connection	Full screw connection	Partial screw connection	Full screw connection
WALCO® Z40	Internal wall : 60x60 External wall : 100x60	10,8	10,8	10,8	10,8	7,60	10,8

Characteristic shear values perpendicular to the direction of insertion $F_{45,Rk}$ [kN] for timber grade C24 and above

Connector	Minimum timber cross section [mm]	No interlayer		OSB ≤ 22 mm**		Plasterboard ≤ 22 mm***	
		Partial screw connection	Full screw connection	Partial screw connection	Full screw connection	Partial screw connection	Full screw connection
WALCO® Z40	Internal wall : 60x60 External wall : 100x60	4,41	4,41	4,41	4,41	3,14	3,93

Serv. class	Values of K_{mod}			
	LDC*	GLT	OSB/3 OSB/4	Plaster board
1	Permanent	0,6	0,4	0,2
	Long	0,7	0,5	0,4
	Medium	0,8	0,7	0,6
	Short	0,9	0,9	0,8
	Very short to short	1,0	1,0	0,95
	Very short	1,1	1,1	1,1
	γ_M	1,3	1,3	1,3

* Load Duration Class

* The load capacity values $F_{1,Rk}$; $F_{2,Rk}$ and $F_{45,Rk}$ have been updated according to the expert report of 30.06.2021, in connection with ETA-10/0189 (2019/10/11).

** OSB/3 or OSB/4 - thickness up to 22 mm according to EN 300 or ETA

*** Plasterboard - thickness up to 22 mm according to EN 15283-2 or ETA

For the determination of $F_{45,Rd}$ when fixing to intermediate materials, the k_{mod} and γ_M factors of the materials are to be taken into account.

KNAPP® CS-screws (WALCO® Z40 will be supplied with the corresponding CS-screws)

Art.-No. Z638 CS-screw 6x50 with drill point (according to ETA 12-0276)

Art.-No. Z639 CS-screw 6x70 with drill point (according to ETA 12-0276)

Application: for fixing the connector parts into the studs.

Art.-No. Z519 KNAPP® CS-screw 10x60 with drill point and reinforced shank

Application: for fixing the connector parts into the studs.

Art.-No. Z523 KNAPP® CS-screw 10x80 with drill point and reinforced shank

Application: When screwing through wood-based panels and cross-laminated timber walls (detail B page 111).

Drilling-template WALCO® Z (Aluminium)

Art.-No. K466 Drilling-template WALCO® Z40

Art.-No. K486 Drilling-template WALCO® Z32

Application: for pre-drilling of screw holes.

Frank PAUBEL © Maison.booa



WALCO® Z32

- Connector for narrow wall joints (32 mm, 1.26 inches) in timber frame, timber panel construction, posts and beams, and cross laminated timber walls (e.g. 38 x 89 mm or 2x4 inches)
- Service class 1 and 2

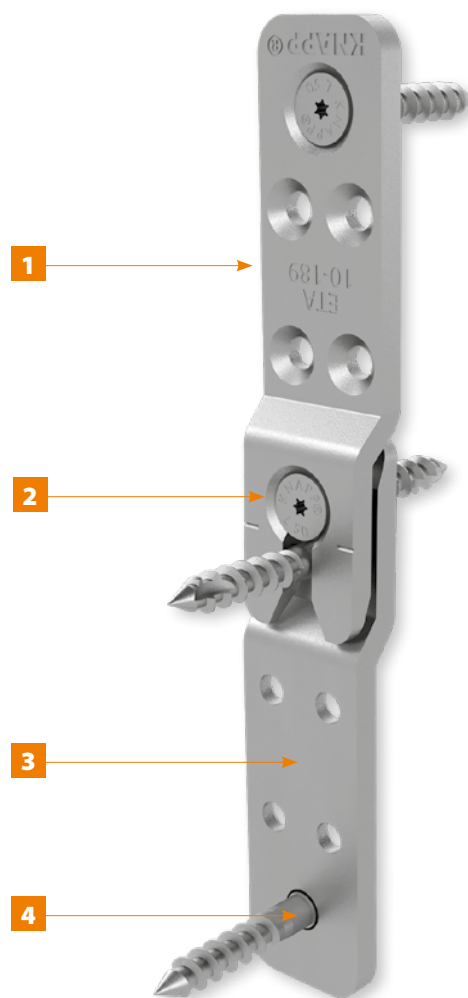

- 1** The stop bevels and the guiding slot for the KNAPP® SC retaining screws bring the connector parts into position and on tension.
- 2** The KNAPP® CS-retaining screw allows for adjustments to the compression of joints.
- 3** WALCO® Z32 consists of two identical connector parts and is made in Austria in high-quality steel.
- 4** The Ø8 mm CS-screws with integrated drilling tip enable rapid fastening with screws; the reinforced shaft provides friction-locked connection.

Fire rating: Fire resistance (EN 1995-1-2) through 3-4 sided concealed, joint-tight installation (R30 ≥ 28 mm, R60 ≥ 49 mm)

WALCO® Z32

WALCO® Z32 - Partial screw connection

Art.-No. K168



Screw connection

Mur 1	Mur 2
2x TF 8x50 mm	2x TF 8x50 mm

Full screw connection :
8x 5x 50 mm

Minimum timber cross section:
L. x Ep. = 2 x 4 Inch
(50 x 100 mm)

WALCO® Z32 - Full screw connection

Art.-No. K168

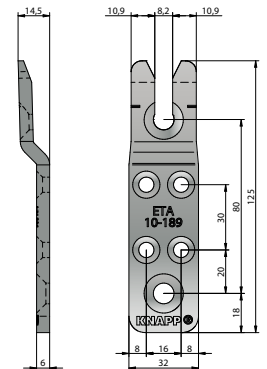

Examples and connection details

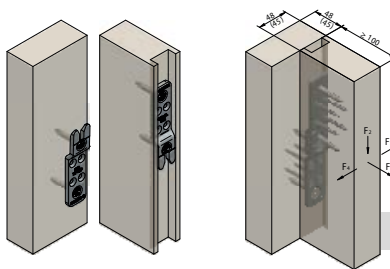

Corner connection

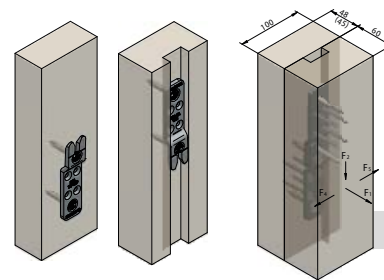

Straight connection

Tensile values*

Characteristic tensile values $F_{1,Rk}$ [kN] for timber grade C24 and above

Connector	Minimum timber cross section [mm]	No interlayer		OSB ≤ 22 mm**		Plasterboard ≤ 22 mm***	
		Partial screw connection	Full screw connection	Partial screw connection	Full screw connection	Partial screw connection	Full screw connection
WALCO® Z32	Internal wall : 60x60 External wall : 100x60	3,64	3,64	3,64	3,64	3,64	3,64

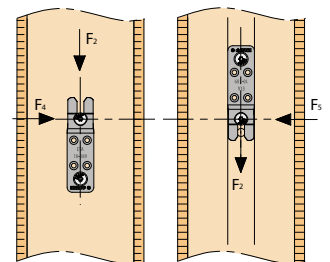
Characteristic resistance in the direction of insertion $F_{2,Rk}$ [kN] for timber grade C24 and above

Connector	Minimum timber cross section [mm]	No interlayer		OSB ≤ 22 mm**		Plasterboard ≤ 22 mm***	
		Partial screw connection	Full screw connection	Partial screw connection	Full screw connection	Partial screw connection	Full screw connection
WALCO® Z32	Internal wall : 60x60 External wall : 100x60	8,20	9,0	8,56	9,0	5,96	9,0

Characteristic resistance perpendicular to the direction of insertion $F_{45,Rk}$ [kN] for timber grade C24 and above

Connector	Minimum timber cross section [mm]	No interlayer		OSB ≤ 22 mm**		Plasterboard ≤ 22 mm***	
		Partial screw connection	Full screw connection	Partial screw connection	Full screw connection	Partial screw connection	Full screw connection
WALCO® Z32	Internal wall : 60x60 External wall : 100x60	3,39	3,76	3,70	3,76	2,52	3,12

Value of K_{mod}				
Serv. class	LDC*	GLT	OSB/3 OSB/4	Plaster board
1	Permanent	0,6	0,4	0,2
	Long	0,7	0,5	0,4
	Medium	0,8	0,7	0,6
	Short	0,9	0,9	0,8
	Very short	1,0	1,0	0,95
	Very short	1,1	1,1	1,1
	γ_M	1,3	1,3	1,3

* Load Duration Class

* The load capacity values $F_{1,Rk}$; $F_{2,Rk}$ and $F_{45,Rk}$ have been updated according to the expert report of 30.06.2021, in connection with ETA-10/0189 (2019/10/11).

** OSB/3 or OSB/4 - thickness up to 22 mm according to EN 300 or ETA

*** Plasterboard - thickness up to 22 mm according to EN 15283-2 or ETA

For the determination of $F_{45,Rd}$ when fixing to intermediate materials, the k_{mod} and γ_M factors of the materials are to be taken into account.

KNAPP® CS-screws (WALCO® Z40 will be supplied with the corresponding CS-screws)

Art.-No. Z533 and Z534 KNAPP® CS-screw 5x50 and 5x80 with drill point and reinforced shank

Application: for fixing the connector parts into the studs.

Art.-No. Z531 KNAPP® CS-screw 8x50 with drill point and reinforced shank

Application: fixing the connector parts into the studs.

Art.-No. Z532 KNAPP® CS-screw 8x80 with drill point and reinforced shank.

Application: When screwing through wood-based panels and cross-laminated timber walls (detail B page 111).

Connecting systems for prefabricated walls

Connecting timber frame constructions up to 16 kN*

- | Timber width from 80 mm
- | Fast and accurate assembly on site – fully prefabricated walls are assembled without any screwing or nailing
- | Stable from the first wall corner
- | Quick and easy assembly through the spacious V-shaped bracket
- | Collar screw and collar bolt are screwed directly into the building component with or without intermediate layer
- | Hanging of end walls and later insertion of intermediate walls
- | Adjustment of joint spacings e.g. for gaskets
- | No milling necessary for panel thicknesses 13/15 mm

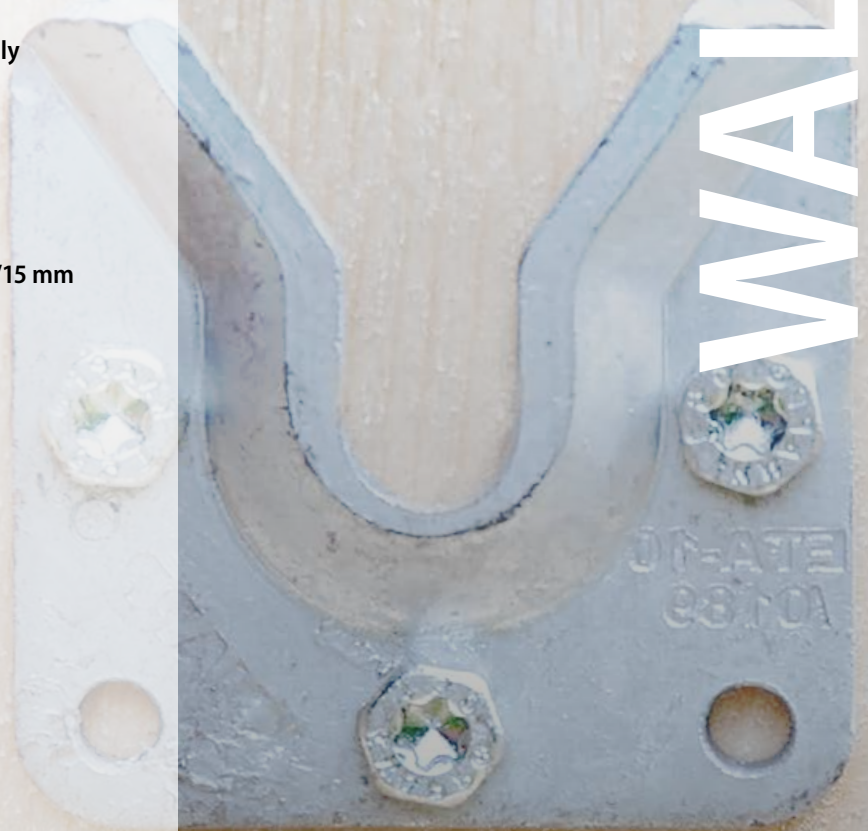

WALCO® V

Available in 2 sizes and 5 versions.

Design values are available on our website under Planer Service.

* Characteristic value $F_{2,RK}$ in slide-in direction, valid only with the use of original KNAPP® CS screws, on C24 according ETA 10/0189 (2022/08/25). Data refers to the use of 3 original KNAPP® hexagon head screws.



Prutscher © Christian Schneider Photography

WALCO® V

- ▮ Applications: concealed wall connections
- ▮ Connections: solid wood, glulam, CLT, MAGNUMBOARD® OSB, steel and concrete
- ▮ Areas of application: timber frame construction and prefabricated house construction
- ▮ Service class 1 and 2

Installation example: wall connection.

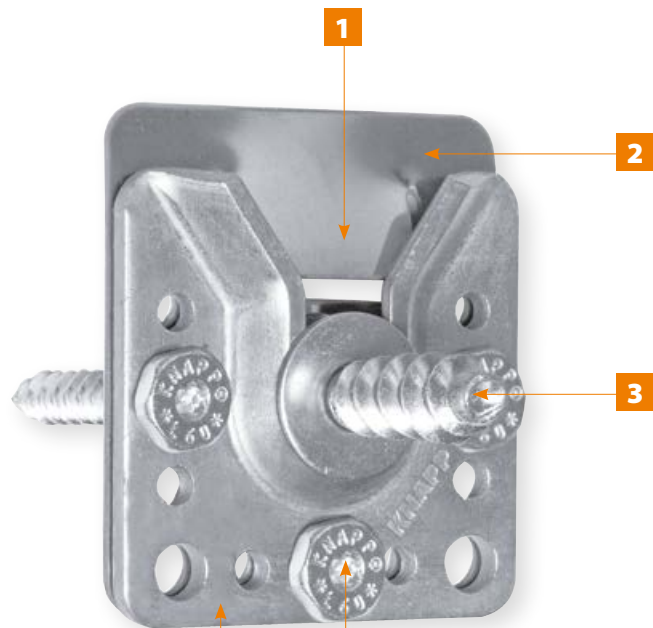

- 1** The generous v-shaped bracket slides the holding screw into place.
- 2** The WALCO® V locking clip (optional) made of stainless spring steel locks against the slide-in direction, thereby transferring the transmission of the anchor tensile force Z_A from one wall to the next.
- 3** The WALCO® V holding screw is the counter part to the connector. Available in 4 versions.
- 4** WALCO® V hexagon head screws for screwing with Torx or hexagon nut.
- 5** WALCO® V is made in Germany from high-quality hot-dip galvanised steel.

Fire protection: fire resistance (EN 1995-1-2) through 3-sided concealed, tight-joint mounting ($R_{30} \geq 28 \text{ mm}$, $R_{60} \geq 49 \text{ mm}$)

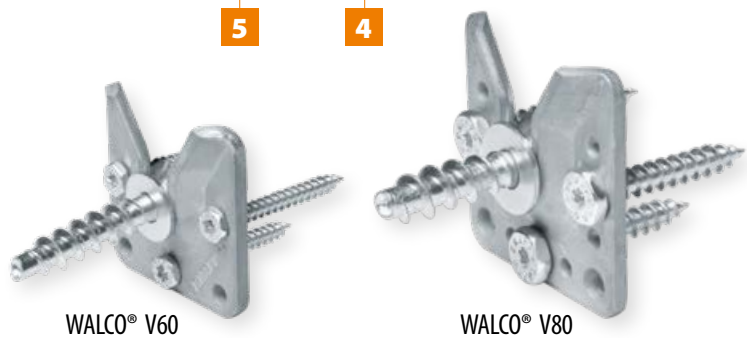

made in Germany ETA-10/0189 (2022/08/25) **WALCO V**

WALCO® V60 and WALCO® V80

Application examples and connection details

(Dimensions in mm - W = WIDTH, t = THICKNESS)

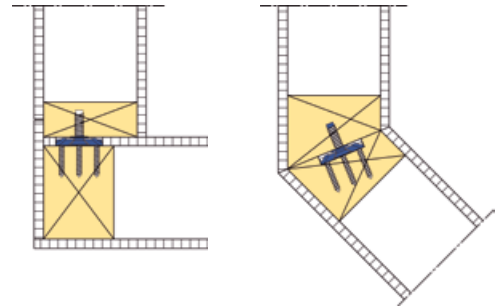
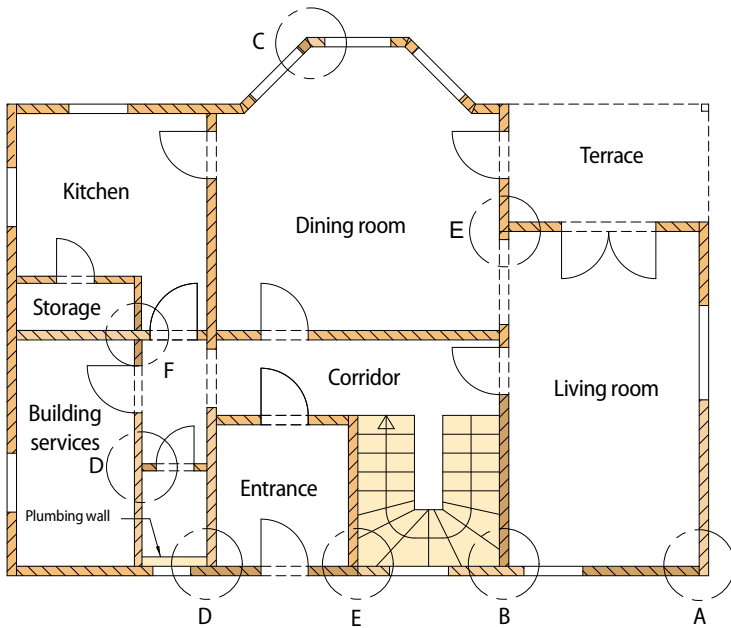

Detail A₁:

External wall corner, planked with wood-based panel

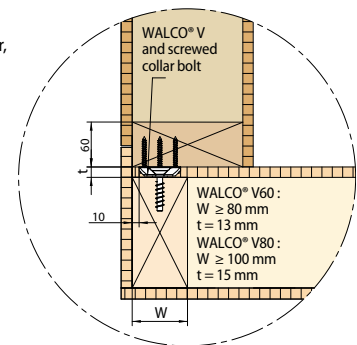

Detail A₂:

Exterior wall corner with vapor barrier (PE-Im)

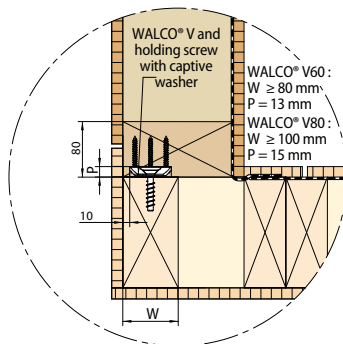

Detail B:

Connection of exterior with interior wall

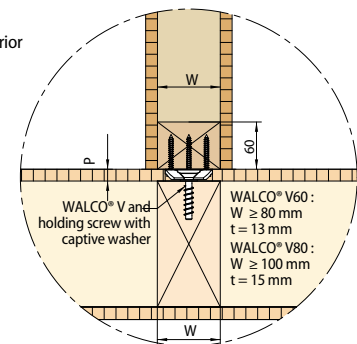

Detail C:

Exterior wall mitre joint

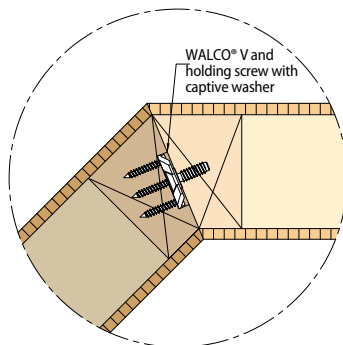

Detail D:

Interior wall connection (e. g. plumbing wall)

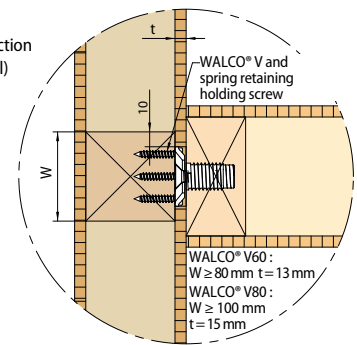

Detail E:

Straight joint for exterior or interior walls

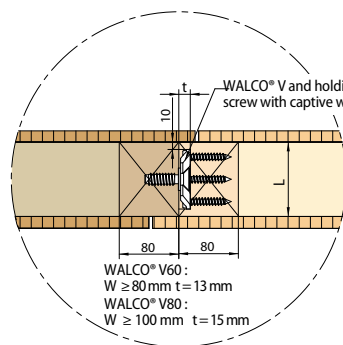

Detail F:

Internal wall double connection

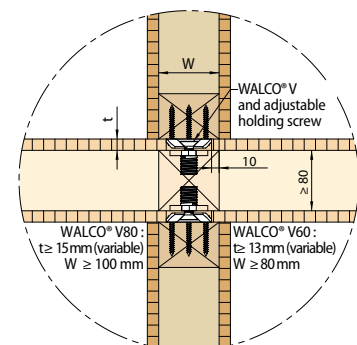

WALCO® V60 and WALCO® V80

Load-bearing capacities for WALCO® V with collar screw (KS)

KNAPP® Connectors	Timber grade	Characteristic values			Design values $F_{1,Rd}$ [kN]		Design values $F_{2,Rd}$ [kN]		Design values $F_{3,Rd}$ [kN]		Design values $F_{45,Rd}$ [kN]	
		$F_{1,Rk}$ [kN]	$F_{2,Rk}$ [kN]	$F_{45,Rk}$ [kN]	k_{mod} [SC* 1+2]			k_{mod} [SC* 1+2]		k_{mod} [SC* 1+2]		
					0,9	0,6	0,9	0,9	0,6	0,9		
WALCO® V60 KS	C24	6,49	5,94	3,88	4,49	2,74	4,11	1,3	1,3	1,79	2,69	
	GL24h	7,00	6,53	4,27	4,85	3,01	4,52			1,97	2,96	
	CLT	6,93	6,45	4,22	4,80	2,98	4,47			1,95	2,92	
WALCO® V80 KS	C24	7,08	7,10	4,46	4,90	3,28	4,92	1,3	1,3	2,06	3,09	
	GL24h	7,64	7,81	4,91	5,29	3,60	5,41			2,27	3,40	
	CLT	7,56	7,71	4,85	5,23	3,56	5,34			2,24	3,36	

*SC = service class

$F_{1,Rd}$ Design values for tension
 $F_{2,Rd}$ Design values in direction of insertion
 $F_{3,Rd}$ Design values against the direction of insertion
 $F_{45,Rd}$ Design values perpendicular to the direction of insertion

k_{mod} Modification factors depending on material, load duration and service class
 $k_{mod} = 0,6 \Rightarrow$ Permanent (more than 10 years for example self weight)
 $k_{mod} = 0,8 \Rightarrow$ Medium term (1 week - 6 months for example imposed floor load, snow load)
 $k_{mod} = 0,9 \Rightarrow$ Short term (shorter than one week, for example snow- and wind load)

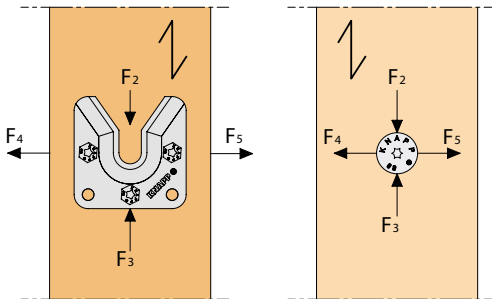

The characteristic values and design values for each load direction on solid wood, glued laminated timber and other wood materials are available on our website under the Planner Service tab or on request.

Practical examples

The values listed below are given as an example and calculated according to EN 1991-1-4. The following table gives you recommendations regarding the wall length W in addition to the wind load w_d and also the number of installed connectors. The wind load $w_d = 0,6 \text{ kN/m}^2$ to the designed wind load of German midland wind area 1 (impact pressure $q = 0,5 \text{ kN/m}^2$, aerodynamics factor $c_{pe} = 0,8$, $v = 102 \text{ km/h}$).

The listed wind loads are referring to the following wind areas:

- $w_d = 1,0 \text{ kN/m}^2$ ($q = 0,8 \text{ kN/m}^2$, $c_{pe} = 0,8$, $v = 129 \text{ km/h}$)
- $w_d = 1,5 \text{ kN/m}^2$ ($q = 1,25 \text{ kN/m}^2$, $c_{pe} = 0,8$, $v = 160 \text{ km/h}$)
- $w_d = 1,9 \text{ kN/m}^2$ ($q = 1,55 \text{ kN/m}^2$, $c_{pe} = 0,8$, $v = 179 \text{ km/h}$) $18 \text{ m} < H \leq 25 \text{ m}$

Derivation: $w_d = \gamma Q \cdot c_{pe} \cdot q = \gamma Q = 1,5$

Table 1: Wall width B in dependence of the number of connectors and wind load.

We recommend min. 3 WALCO® V connectors for external wall corner.

Qty/joint	Connector	Max. length of wall B [m]			
		Designed wind load [kN/m ²]			
		$w_d = 0,6$	$w_d = 1,0$	$w_d = 1,5$	$w_d = 1,9$
3	WALCO® V60 KS	9,0	5,4	3,6	2,8
4		12,0	7,2	4,8	3,8
5		14,9	9,0	6,0	4,7
3	WALCO® V80 KS	10,3	6,2	4,1	3,3
4		13,7	8,2	5,5	4,3
5		17,2	10,3	6,9	5,4

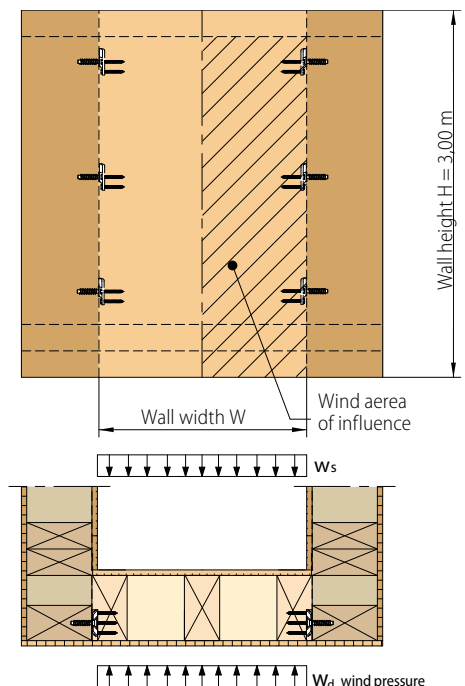

The graph shows the load directions and installation. Design values given in the table below should be used for structural analysis according to EC5 (EN 1995-1-1). The values listed below are given as examples and valid for Germany only!

WALCO® V60 and WALCO® V80

Permissible load values with interlayer

WALCO® V directly to intermediate layer (cladding) attached:

When fixing the WALCO® V connector to an intermediate layer, the design values listed below come into effect, these refer to the ETA-10/0189 and on the DIN 1995-1-1 (EC5). The values are subdivided into the different load duration classes (LDC) and the load directions. In addition, it should be noted that the intermediate layer is force-fitted to the timber stud with screws, nails or staples (see picture below).

Thickness t_{zw} [mm]	Interlayer/ Stud	WALCO® V60 with 5 screws 6x80 1 screw 12x60				WALCO® VV80 with 5 screws 10x80 1 screw 16x60			
		Design values of load-bearing capacity F_{Rd} [kN]				Design values of load-bearing capacity F_{Rd} [kN]			
		$F_{2,Rd}$ [kN] [permanent]	$F_{2,Rd}$ [kN] [medium]	$F_{2,Rd}$ [kN] [short]	$F_{45,Rd}$ [kN] [short]	$F_{2,Rd}$ [kN] [permanent]	$F_{2,Rd}$ [kN] [medium]	$F_{2,Rd}$ [kN] [short]	$F_{45,Rd}$ [kN] [short]
12	Plasterboard / C24	1,4	2,8	3,4	2,7	2,1	4,2	4,9	3,1
15		1,5	3,0	3,7		2,3	4,4		
12	OSB Plate / C24	2,4	3,7	4,1	2,7	2,8	4,4	4,9	3,1
15		2,2	3,7	4,1		2,8	4,4		
13	Particleboard / C24	1,9	3,3	4,0	2,7	2,3	3,9	4,8	3,1
19		1,8	3,1	3,8		2,3	4,0		
13	Particleboard / C24	2,7	3,7	4,1	2,7	3,3	4,4	4,9	3,1
15						3,3	4,4		

WALCO® V60

(Dimensions in mm)

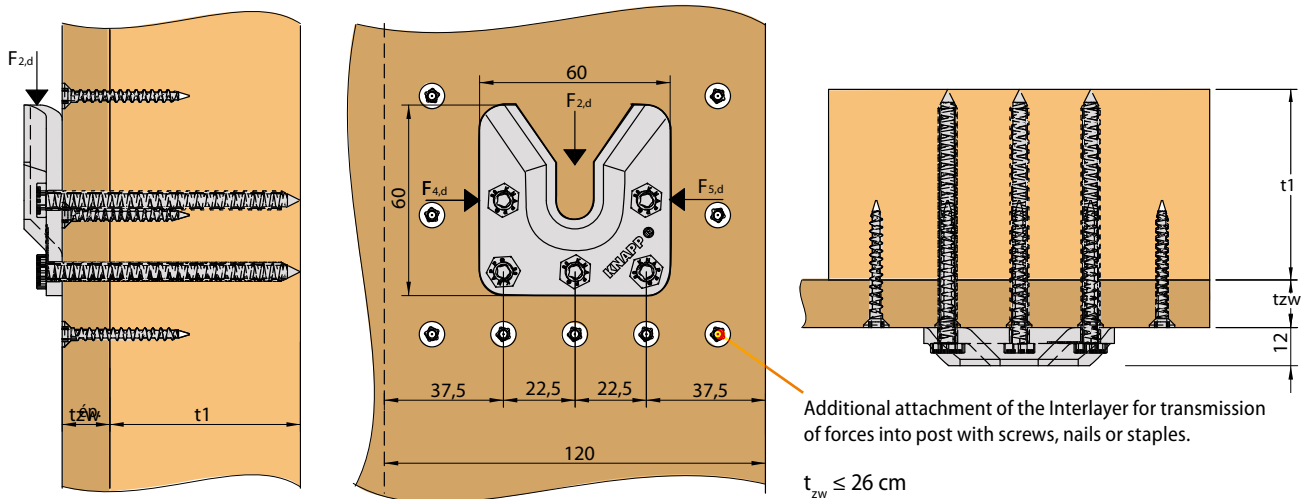

WALCO® V80

(Dimensions in mm)

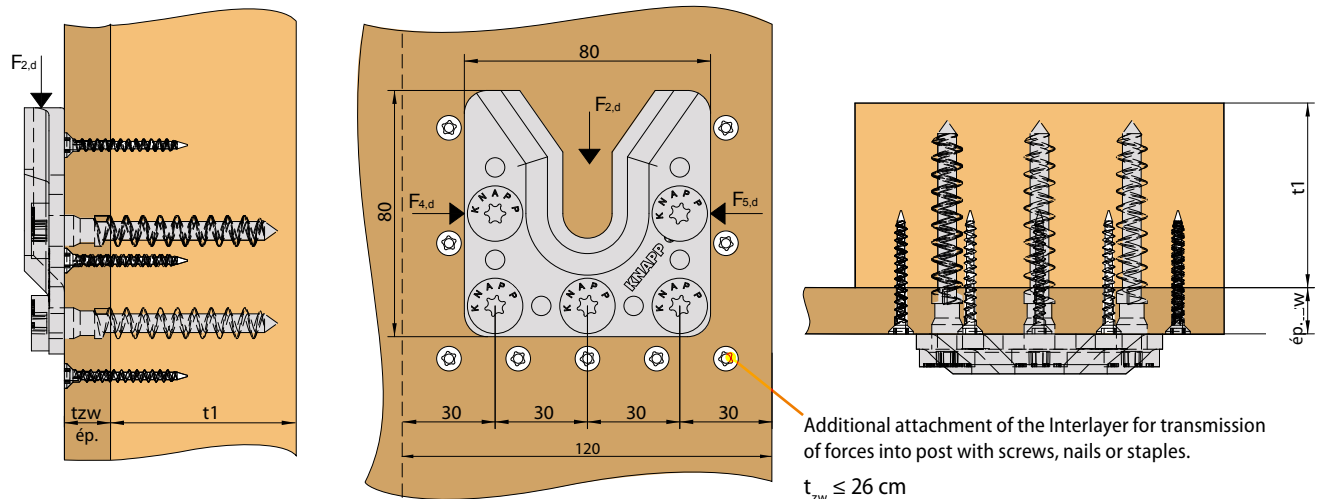

WALCO® V80

Characteristic values of load-bearing capacity for WALCO® V with collar screw (KS) on **MAGNUMBOARD®** OSB

KNAPP® Connector	Minimal wall thickness [mm]	Characteristic values of of load-bearing capacity F_{Rk} on MAGNUMBOARD® OSB					
		Tensile force $F_{1,Rk}$ [kN]		Shear force $F_{2,Rk}$ [kN]		Shear force $F_{45,Rk}$ [kN]	
		$F_{1,0,Rk}$	$F_{1,90,Rk}$	$F_{2,0,Rk}$	$F_{2,90,Rk}$	$F_{45,0,Rk}$	$F_{45,90,Rk}$
WALCO® V80 KS	100	3,5	8,8	3,7	5,3	3,7	5,3

- $F_{1,0,Rk}$ Tensile force in **MAGNUMBOARD®** OSB end-grain timber
 $F_{1,90,Rk}$ Tensile force in **MAGNUMBOARD®** OSB side timber
 $F_{2,0,Rk}$ Shear force in insertion direction in **MAGNUMBOARD®** OSB end grain
 $F_{2,90,Rk}$ Shear force in insertion direction in **MAGNUMBOARD®** OSB side timber
 $F_{45,0,Rk}$ Shear force perpendicular to the direction of insertion in **MAGNUMBOARD®** OSB end grain
 $F_{45,90,Rk}$ Shear force perpendicular to the direction of insertion in **MAGNUMBOARD®** OSB side timber

Note

The load-bearing values have been calculated according to ETA 10-0189 (2019/10/11).



VIDEO

Tensile force F_1 design values

KNAPP® Connector	Tensile force $F_{1,0,Rd}$ in MAGNUMBOARD® OSB end grain depending on the load duration class (LDC)					
	permanent	long	medium	short	short/very short	very short
	$k_{mod} = 0,4$	$k_{mod} = 0,5$	$k_{mod} = 0,7$	$k_{mod} = 0,9$	$k_{mod} = 1,0$	$k_{mod} = 1,1$
WALCO® V80 KS	1,08	1,34	1,88	2,42	2,69	2,96

KNAPP® Connector	Tensile force $F_{1,90,Rd}$ in MAGNUMBOARD® OSB wide face in dependence of the load duration (LDC)					
	permanent	long	medium	short	short/very short	very short
	$k_{mod} = 0,4$	$k_{mod} = 0,5$	$k_{mod} = 0,7$	$k_{mod} = 0,9$	$k_{mod} = 1,0$	$k_{mod} = 1,1$
WALCO® V80 KS	2,72	3,40	4,76	6,11	6,79	7,47

Shear force F_2 design values in direction of insertion

KNAPP® Connector	Shear force $F_{2,0,Rd}$ in MAGNUMBOARD® OSB end grain depending on the load duration (LDC)					
	permanent	long	medium	short	short/very short	very short
	$k_{mod} = 0,4$	$k_{mod} = 0,5$	$k_{mod} = 0,7$	$k_{mod} = 0,9$	$k_{mod} = 1,0$	$k_{mod} = 1,1$
WALCO® V80 KS	1,14	1,43	2,00	2,57	2,85	3,14

KNAPP® Connector	Shear force $F_{2,90,Rd}$ in MAGNUMBOARD® OSB wide face depending on the load duration (LDC)					
	permanent	long	medium	short	short/very short	very short
	$k_{mod} = 0,4$	$k_{mod} = 0,5$	$k_{mod} = 0,7$	$k_{mod} = 0,9$	$k_{mod} = 1,0$	$k_{mod} = 1,1$
WALCO® V80 KS	1,63	2,04	2,85	3,67	4,08	4,48

Shear force F_{45} design values of perpendicular to the direction of insertion

KNAPP® Connector	Shear force $F_{45,0,Rd}$ in MAGNUMBOARD® OSB end grain depending on the load duration class (LDC)					
	permanent	long	medium	short	short/very short	very short
	$k_{mod} = 0,4$	$k_{mod} = 0,5$	$k_{mod} = 0,7$	$k_{mod} = 0,9$	$k_{mod} = 1,0$	$k_{mod} = 1,1$
WALCO® V80 KS	1,14	1,43	2,00	2,57	2,85	3,14

KNAPP® Connector	Shear force $F_{45,90,Rd}$ in MAGNUMBOARD® OSB side timber depending on the load duration class (LDC)					
	permanent	long	medium	short	short/very short	very short
	$k_{mod} = 0,4$	$k_{mod} = 0,5$	$k_{mod} = 0,7$	$k_{mod} = 0,9$	$k_{mod} = 1,0$	$k_{mod} = 1,1$
WALCO® V80 KS	1,63	2,04	2,85	3,67	4,08	4,48

Illustrating a WALCO® V80 external wall corner joint in MAGNUMBOARD® OSB:

(Dimensions in mm)

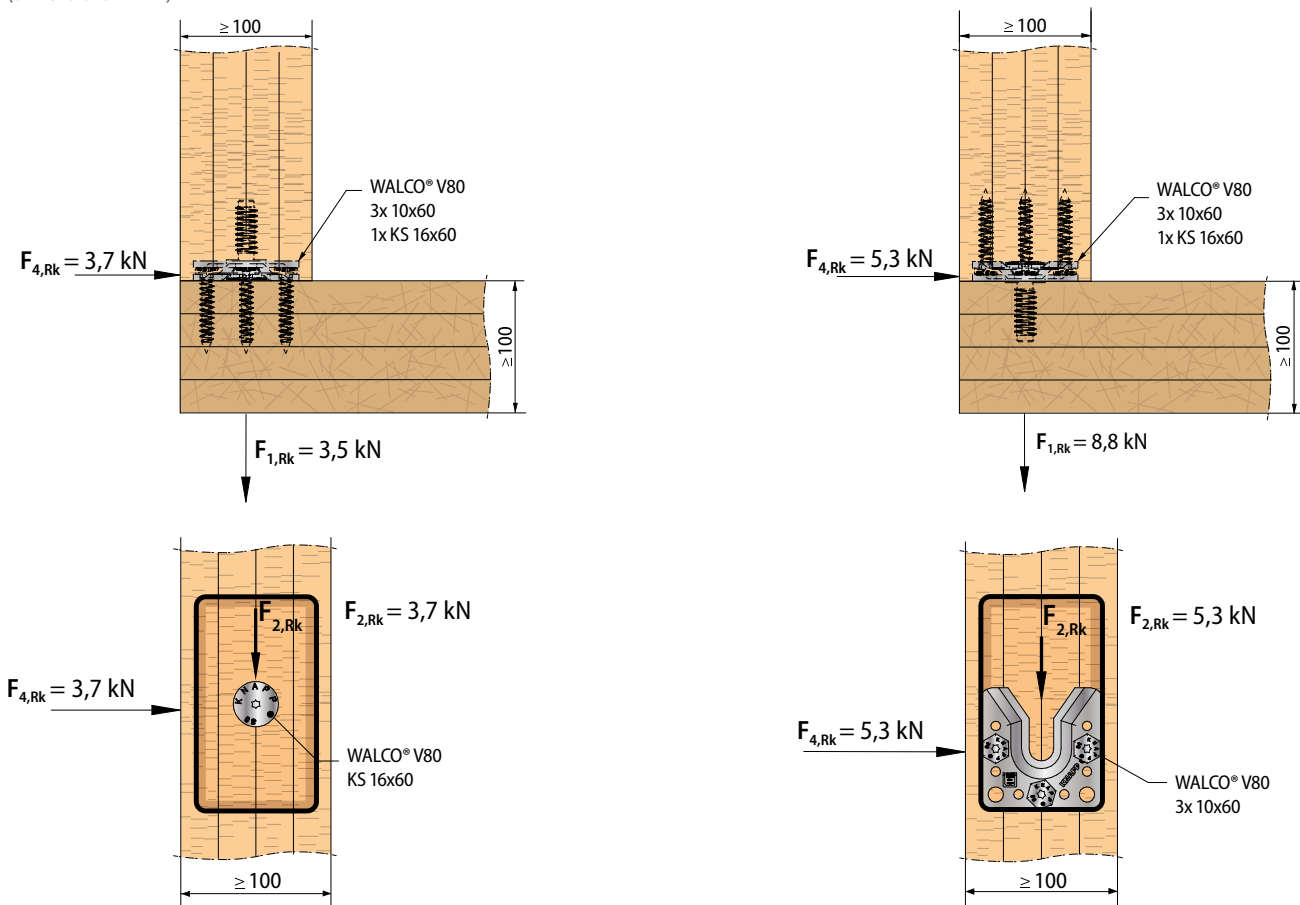

Illustrating a WALCO® V80 external wall joint in MAGNUMBOARD® OSB:

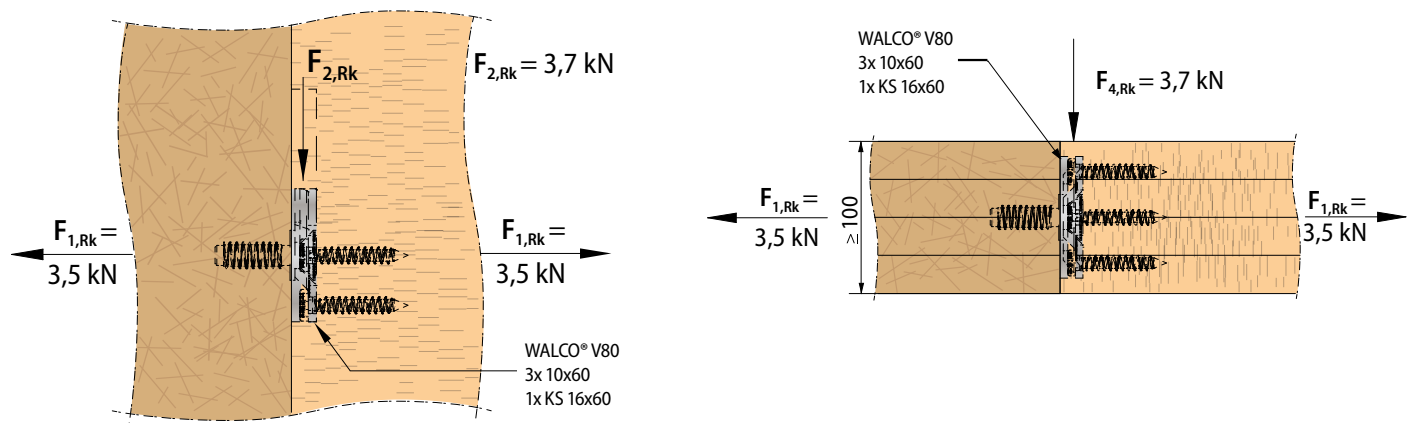

WALCO® V60

WALCO® V60 includes holding screw and hex-head wood screws

(Dimensions in mm)

Holding bolt wall #1	Screws wall #2	Characteristic values [C24]		
		F _{2,Rk} [kN]	F _{45,Rk} [kN]	F _{1,Rk} [kN]
KS 12x60	3 screws 6x50	5,9	3,9	6,5
VK D12	3 screws 6x50	4,9	3,2	6,4
EH M12	3 screws 6x50	4,8	2,9	4,7
GH M12	3 screws 6x50	8,6	5,4	7,1

Minimum timber cross section: L x t = 80 x 60 mm

Walco V60 (KS) collar screw

Art.-No.K102

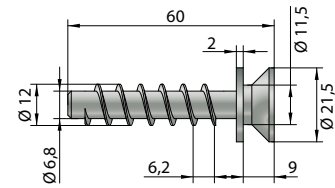
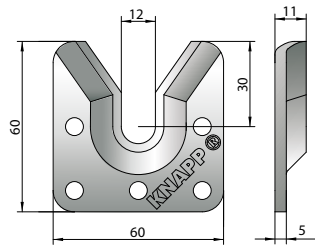
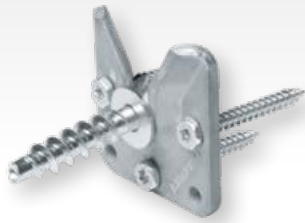

Walco V60 (VK) collar bolt

Art.-No.K108

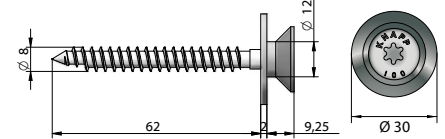
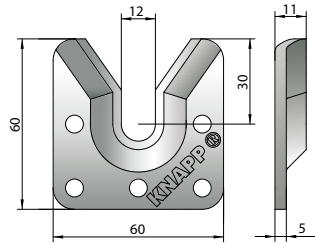

Walco V60 (EH) adjustable retaining screw collar bolt

Art.-No.K104

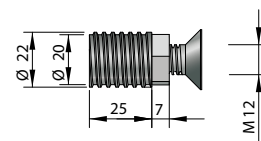
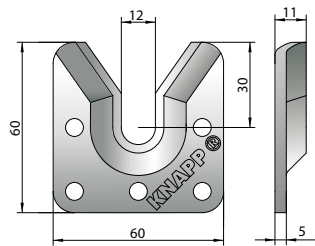
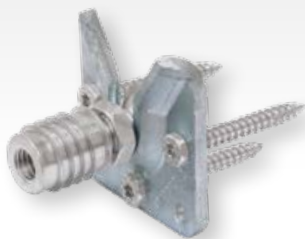

Walco V60 (GH) spring loaded collar bolt

Art.-No.K106

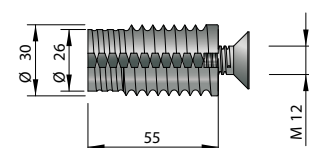
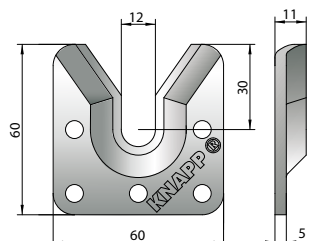

WALCO® V80

WALCO® V80 includes holding screw and hex-head wood screws

(Dimensions in mm)

Holding bolt wall #1	Screws wall #2	Characteristic values [C24]		
		F _{2,Rk} [kN]	F _{45,Rk} [kN]	F _{1,Rk} [kN]
KS 16x60	3 screws 10x60	7,1	4,5	7,1
VK D16	3 screws 10x60	6,2	4,1	7,1
EH M16	3 screws 10x60	6,5	3,7	6,0
GH M16	3 screws 10x60	16,0	9,1	10,0

Minimum timber cross section: L x t = 100 x 60 mm

Walco V80 (KS) collar screw

Art.-No.K103

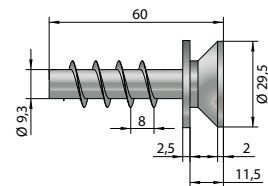
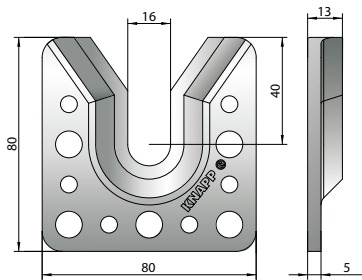
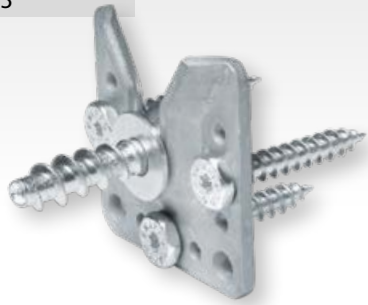

Walco V80 (VK) collar bolt

Art.-No.K109

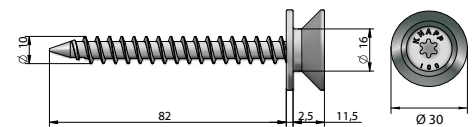
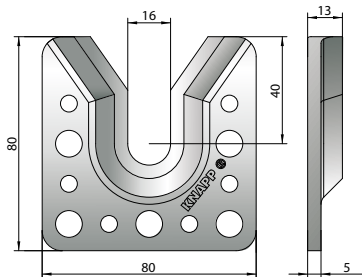

Walco V80 (EH) adjustable retaining screw collar bolt

Art.-No.K105

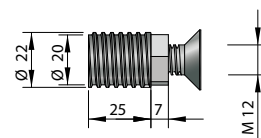
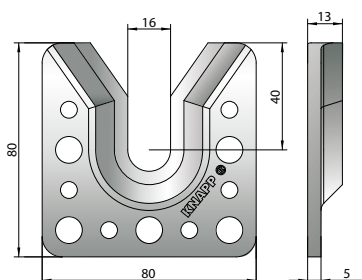

Walco V80 (GH) spring loaded collar bolt

Art.-No.K107

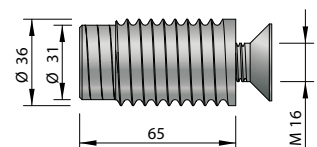
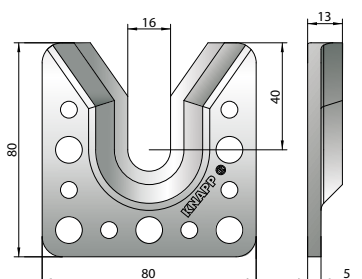
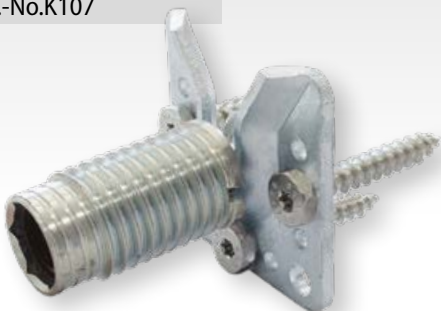

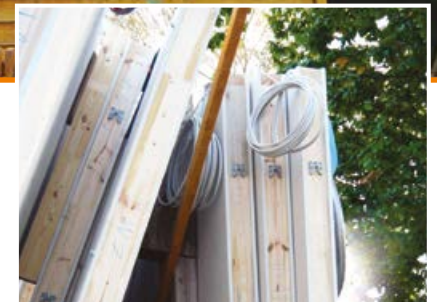

© Holzhaus Schröder

WALCO® V80 oblong-hole

- Stable and invisible connection for prefabricated wall elements made of wood and CLT wall, as well as connections to wood, steel and concrete.
- Re-adjustment possible due to the slotted holes
- Positioning tolerance +/- 15 mm in height and +/- 2 mm in width for later compensation of unevenness on the building site
- Load-bearing in the direction of tension as well as at right angles to the direction of insertion

Installation example:
WALCO® V

Adjustability

(Dimensions in mm)

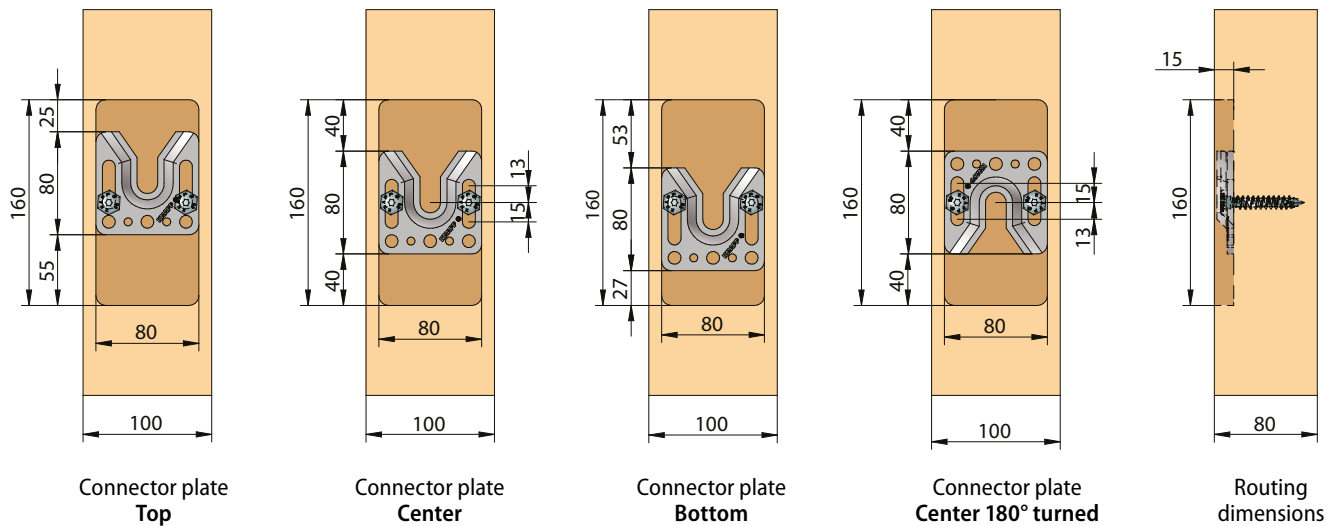

Load values

Connector	Timber grade	Min. cross section of square timber	Charact. values F _{45,Rk} [kN]	Design values F _{45,Rd} [kN]	
				k _{mod} [service class 1+2]	
				0,9	1,0
WALCO® V 80 oblong hole	C24	100x60 for KS and 100x80 for oblong hole plate	4,46	3,09	3,43
	GL24h		4,91	3,40	3,78
	CLT		4,85	3,36	3,73



Installation example: WALCO® V
Oblonghole directly bolted on a OSB board.

CLT with characteristic bulk density $r_k \geq 380 \text{ kg/m}^3$

Load direction F₂ and F₃ cannot be used due to the connector's adjustability.

WALCO® V60 and WALCO® V80

WALCO® V hexagonal - head, self-tapping wood screws

Art.-No. Z550

V60 hex-head wood screw 6x50



Art.-No. Z551

V80 hex-head wood screw 10x60

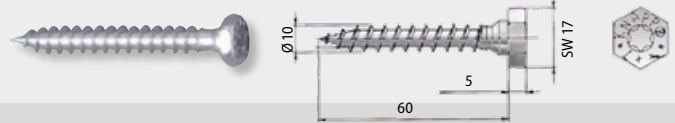

Application: to screw on WALCO® V.

Accessories

WALCO® V marking template (stainless steel)

Art.-No. K578

WALCO® V60 marking template

Art.-No. K579

WALCO® V80 marking template



WALCO® V60

WALCO® V80

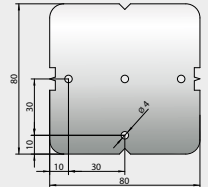
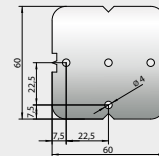

Application: for pre-drilling the pilot holes for exact assembly.

WALCO® V clip lock (made of stainless steel)

Art.-No. K112

WALCO® V60 clip lock

Art.-No. K113

WALCO® V80 clip lock



WALCO® V60

WALCO® V80

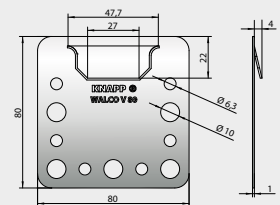
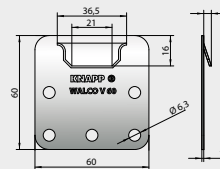

Application: locks and can be loaded against the insertion direction, e.g. when connecting anchor tensile forces.

WALCO® V PH-screws

Art.-No. Z521

PH screw 10x80

Art.-No. Z522

PH screw 10x120



Application: for special solutions such as cladding or angled screw connections.

Project pictures



Photos 1 and 2 © P. Lienbacher Holzbauwerk GmbH, artofisight GesbR

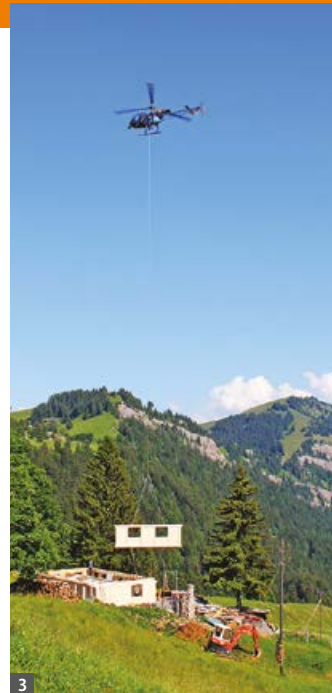

Photos 3 and 4 © Holzwerkstatt EBI

WALCO® V

Installation

- Simple and fast fabrication with router and optional KNAPP® marking template.
- Installation with CNC joinery machine possible – all data for the standard CNC joinery machine programs is included.

WALCO® V milling dimensions

	Width	Length	Depth
V60	60 mm	80 mm	13 mm
V80	80 mm	100 mm	15 mm
V80L	80 mm	160 mm	15 mm

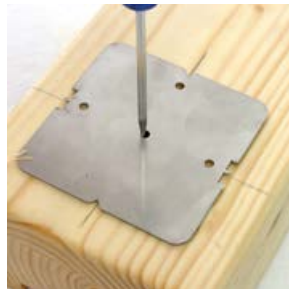
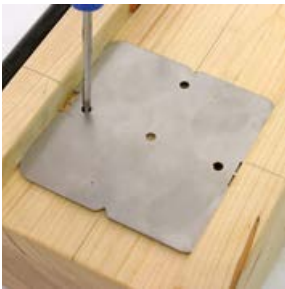

If necessary make milling, mark drilling



CNC joinery machine, router or portable router



Pre-drill assembly instructions



Fasten the WALCO® V to the wood and screw in the WALCO® V retaining screw.



Project pictures



Connectors for facade and modular building

Load-bearing up to 8 kN*

- | Thanks to slotted holes, even faster and more precise assembly on site is possible
- | Compensation for structural irregularities later by means of positioning tolerance of +/- 15 mm in height and +/- 2 mm in width
- | The connector is load-bearing in tensile direction
- | Solid and concealed

WALCO®

Available in 2 sizes and 8 versions.

Design values are available on our website under Planer Service.

* Characteristic value $F_{2,Rk}$ in slide-in direction, valid only with the use of original KNAPP® screws, according to ETA-10/0189 (2022/08/25), for glulam GL24h.



Holzbau Schönder



HASSLACHER Gruppe © GETEC

Installation example: ORF-Studio, Oberstdorf, DE.

WALCO®

- ▮ Applications: concealed and adjustable connectors for facades, wall elements and modular building
- ▮ Connections: for prefabricated wall elements made of wood, CLT or similar, as well as connections of wood to steel or concrete
- ▮ Areas of application: in prefabricated timber house construction, modular construction and facade elements
- ▮ Service class 1 and 2

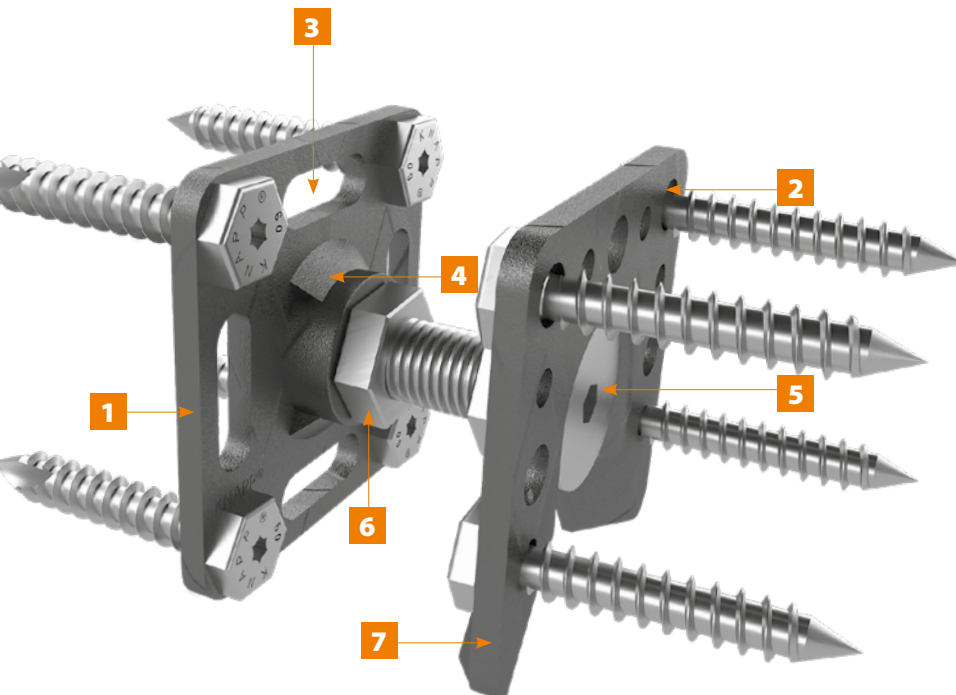

1 WALCO® 80 M16 or WALCO® 60 M12

2 4-point screw

3 Slotted hole screw connection, adjustment - optional

4 Welded threaded sleeve

5 Retaining screw adjustable

6 Lock nut

7 WALCO® V80 or WALCO® V60

The locking screw, secured with a locknut, transmits the tensile forces.



Areas of application and connector types

Universal connections to solid wood, wood-based materials such as CLT or OSB boards, steel or concrete for wood widths of 80 mm and more.

Connector types with respective bolt version and WALCO® V connector plate as a counterpiece



WALCO® V80 VS with welded collar bolt
(Art.-No. K711/Set)



WALCO® 80 M16 with adjustable counter sunk screw
(Art.-No. K712/Set)



WALCO® 80 VK with screw-in collar bolt
(Art.-No. K710/Set)



WALCO® V80 oblong model
(Art.-No. K115/B)
or its alternative **WALCO® V80**
(Art.-No. K101/Set)

Components and accessories

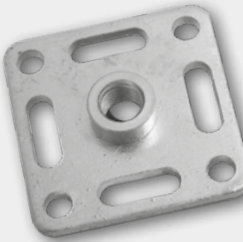

WALCO® 80 M16 pressed-in sleeve
(Art.-No. K712/B)

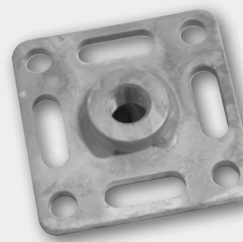

WALCO® 80 M16 with M16 welded sleeve
(Art.-No. K712/V)



WALCO® 80
(Art.-No. K710/B)



Clip lock WALCO® V80 in stainless spring steel (Art.-No. K113)

The base plates are optionally adjustable via slotted holes and the joint distances are adjustable. Possible construction tolerances can be compensated. An optional locking flap made of stainless spring steel, which cannot be seen from the outside, locks and secures the respective connection with a click for loads against the direction of insertion. **WALCO® V (hot-dip galvanized steel) is available in sizes 60 and 80 mm.**

Connectors for curtain walls

(Dimensions in mm)

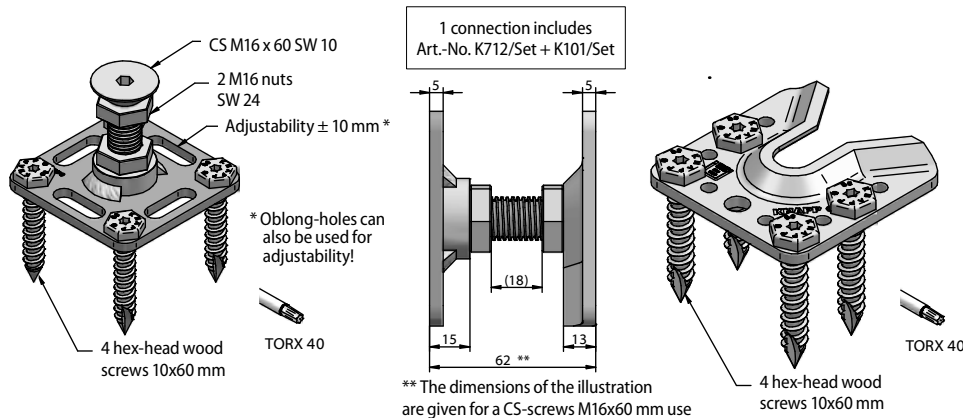

Options

- Two different base plates with counterpart WALCO® V connector plate for easy assembly without further use of screws on the building site.
- Firmly welded support bolt for connecting modular walls.
- Metric thread for precise adjustment of the element spacing for insulated facades.
- The WALCO® V system can be structurally calculated and has a European Technical Assessment (ETA).

Connectors for prefabricated walls

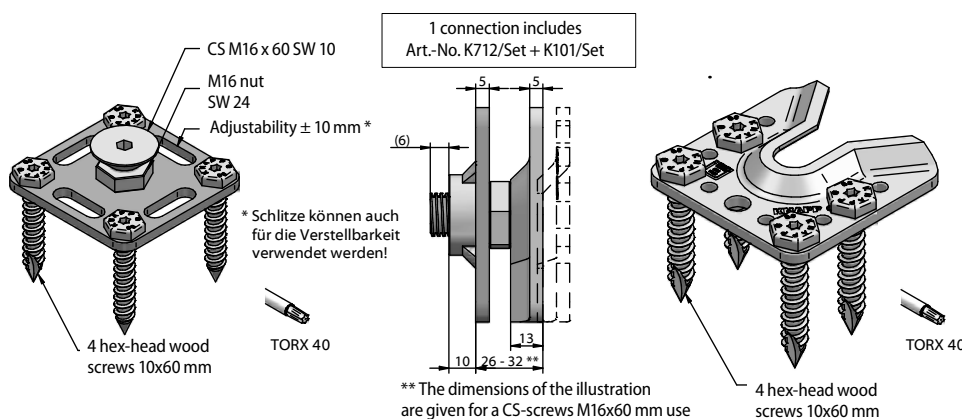

WALCO® 60

WALCO® 60 with holding screw or collar bolt

(Dimensions in mm)

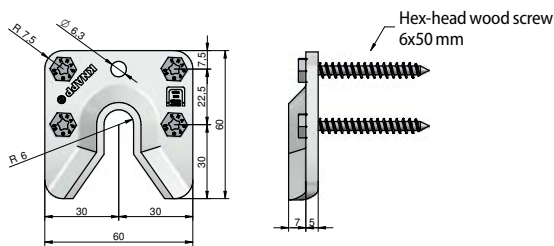

* Hex = hex-head wood screw

F_{1,Rk} = Characteristic values (tension)

F_{2,Rk} = Characteristic values in direction of insertion

F_{45,Rk} = Characteristic values perpendicular to the direction of insertion

Connector	Screws on wall #1	Screws on wall #2	Characteristic values [C24]		
			F _{1,Rk} [kN]	F _{2,Rk} [kN]	F _{45,Rk} [kN]
WALCO® V60 WALCO® 60 VS	WALCO® V60 4 Hex 6x50*	WALCO® V60 VS 4 Hex 6x50*	2,55	4,52	7,57
WALCO® V60 WALCO® 60 VK	WALCO® V60 4 Hex 6x50*	WALCO® 60 VK 4 Hex 6x50* 1 CS 8x80	0,80	4,52	7,57
WALCO® V60 WALCO® 60 EH	WALCO® V60 4 Hex 6x50*	WALCO® 60 EH 4 Hex 6x50*	2,55	2,65	6,21
WALCO® V60 WALCO® 60 EH	WALCO® V60 4 Hex 6x50*	WALCO® 60 EH 4 Hex 6x50*	2,55	2,65	6,21

Min. timber cross-section: WxH = 80 x 60 mm

WALCO® V60 and WALCO® 60 with welded collar bolt (VS)

Art.-No.K100/Set

Art.-No.K701/Set

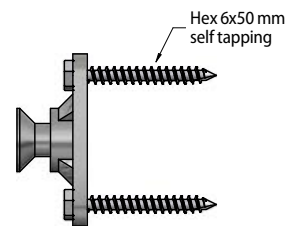
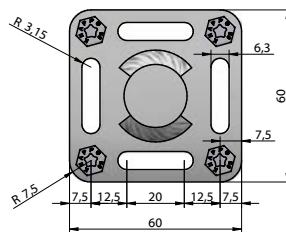

WALCO® V60 and WALCO® 60 with screw-in collar bolt (VK)

Art.-No.K100/Set

Art.-No.K700/Set

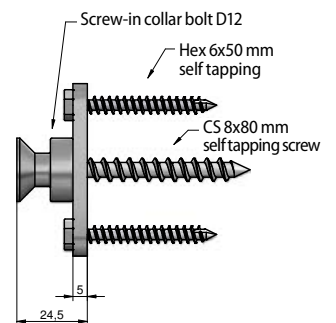
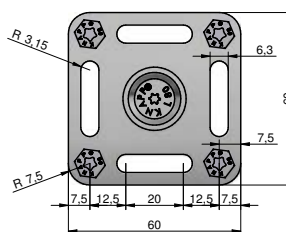
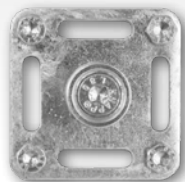

WALCO® V60 and WALCO® 60 with welded sleeve and adjustable counter sunk screw M12 (EH)

Art.-No.K100/Set

Art.-No.K702/Set

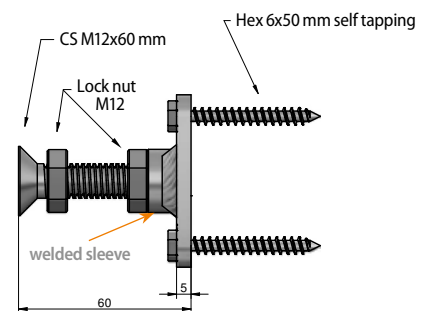
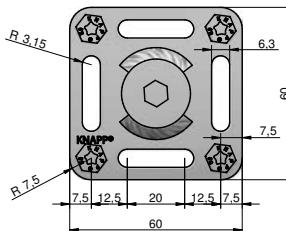
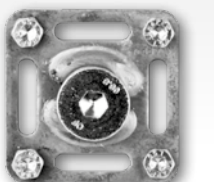

WALCO® V60 and WALCO® 60 pressed-in sleeve with adjustable counter sunk screw M12 (EH)

Art.-No.K100/Set

Art.-No.K704/Set

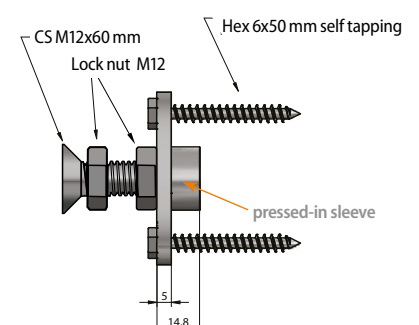
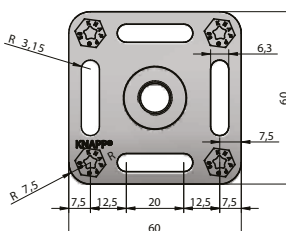

WALCO® 80

WALCO® 80 with holding screw or collar bolt

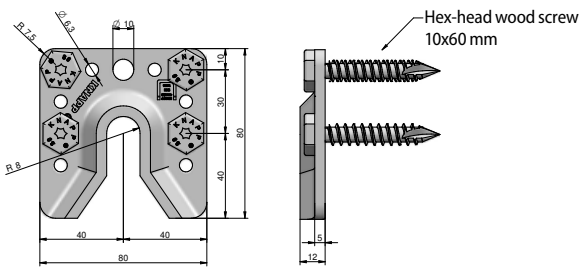

* Hex = hex-head wood screw

F_{1,Rk} = Characteristic values (tension)

F_{2,Rk} = Characteristic values in direction of insertion

F_{45,Rk} = Characteristic values perpendicular to the direction of insertion

Connector	Screws on wall #1	Screws on wall #2	Characteristic values [C24]		
			F _{1,Rk} [kN]	F _{2,Rk} [kN]	F _{45,Rk} [kN]
WALCO® V80 WALCO® 80 VS	WALCO® V80 4 Hex 10x60*	WALCO® V80 VS 4 Hex 10x60*	3,62	7,58	14,18
WALCO® V80 WALCO® 80 VK	WALCO® V80 4 Hex 10x60*	WALCO® 80 VK 4 Hex 10x60* 1 CS 10x100	2,61	7,88	14,18
WALCO® V80 WALCO® 80 EH	WALCO® V80 4 Hex 10x60*	WALCO® 80 EH 4 Hex 10x60*	3,62	3,30	11,90
WALCO® V80 WALCO® 80 EK	WALCO® V80 4 Hex 10x60*	WALCO® 80 EH 4 Hex 10x60*	3,62	3,30	11,90

Min. timber cross-section: WxH = 100 x 60 mm

WALCO® V80 and WALCO® 80 with welded collar bolt (VS)

Art.-No.K101/Set

Art.-No.K711/Set

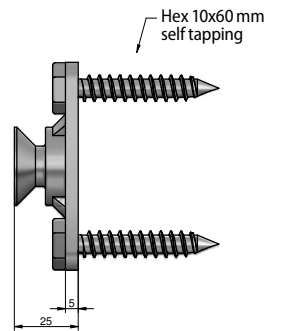
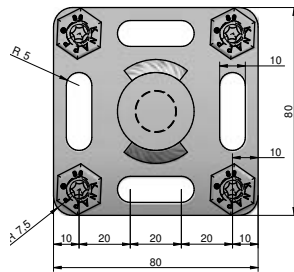

WALCO® V80 and WALCO® 80 with screw-in collar bolt (VK)

Art.-No.K101/Set

Art.-No.K710/Set

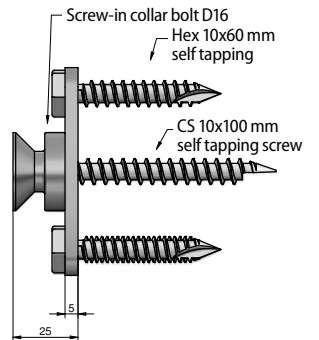
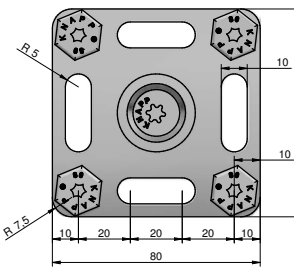
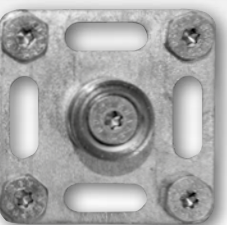

WALCO® V80 and WALCO® 80 with welded sleeve and adjustable counter sunk screw M12 (EH)

Art.-No.K101/Set

Art.-No.K712/Set

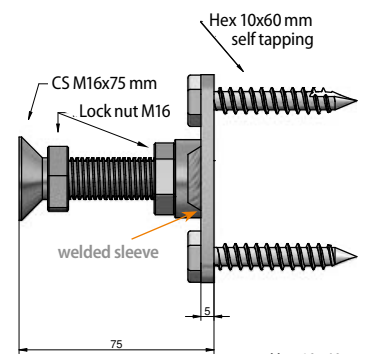
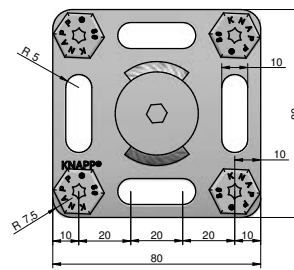

WALCO® V80 and WALCO® 80 pressed-in sleeve with adjustable counter sunk screw M12 (EH)

Art.-No.K101/Set

Art.-No.K713/Set

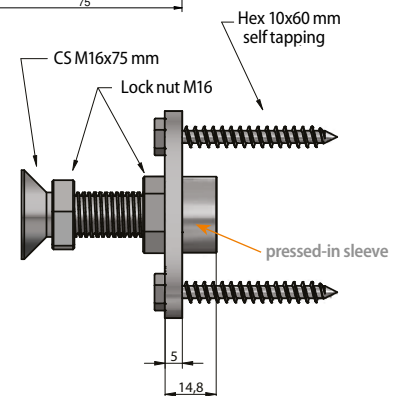
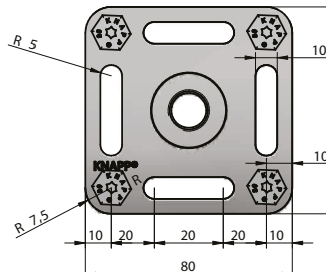
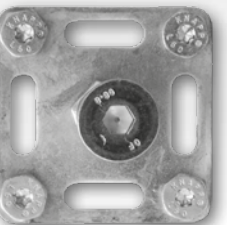



Timber frame construction
Mobile homes, USA



Timber frame construction
Schramm office building, Austria

Leingauer GmbH



Timber frame construction
Roof extension, Germany

Holzbaun Schröder



Timber frame construction
Urban density, London (GB)

Becker & Sohn © STUSD Ltd.



Prefab. house construction
Housing development, Austria

© Schaffner



Timber frame construction
Multi-storey residential building, Germany

© Huber & Sohn GmbH & Co. KG



Timber frame construction
Chalets "Alpegg", Austria

Foidl Holzbau, © de franceschi photography

Anchoring system

Anchoring timber-framed walls,
up to 24,4 kN*

- | Timber width from 100 mm
- | Highly advanced production prefabrication
- | Anchoring by simply interlocking the wall elements
- | Very strong anchoring
- | Disassembly and reassembly without damage

WALCO® BOLT

Available in 3 versions.

Design values are available on our website under Planer Service.

* Characteristic value $F_{1,Rk}$ in tension, valid only with the use of 4 original KNAPP® CS screws 10x60 mm, on C24 according ETA-23/0670 (2023/09/25).

H

S

B



WALCO® BOLT

- ▮ Stable and concealed connection for prefabricated wall elements made of wood and CLT, as well as connections between wood, steel and concrete.
- ▮ The slotted holes of the WALCO® 80 base plate allow for readjustment when attached with screws
- ▮ Loadable with tension as well as perpendicular to the insertion direction
- ▮ Service class 1 and 2



Installation example: fixing carport rafters, Austria.

© KNAFF GmbH

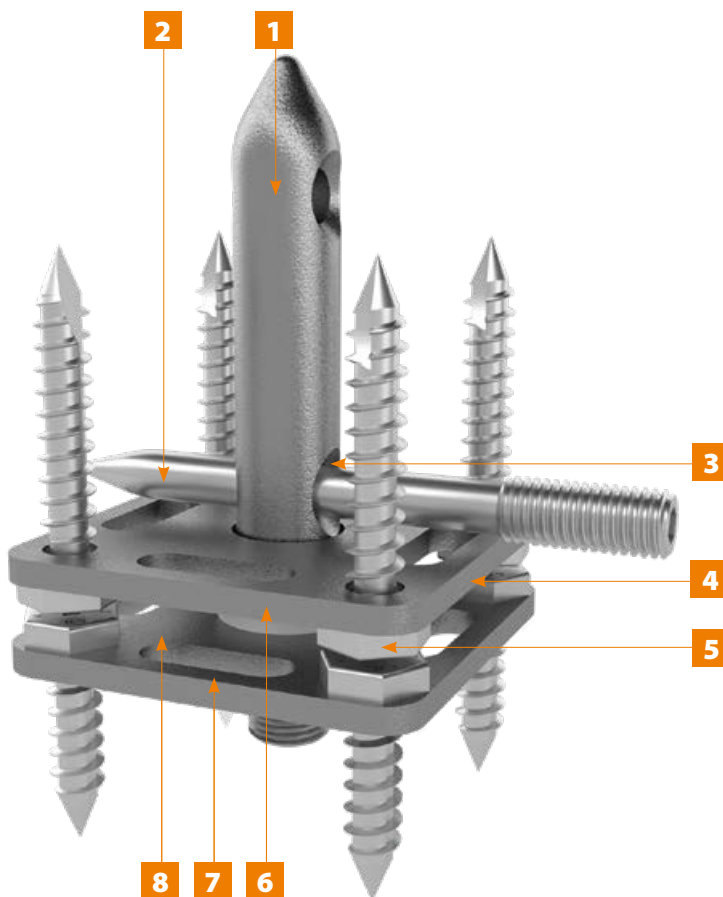

- 1 Ø20 mm bolts for anchoring and connecting wall elements
- 2 Clamping bolt for securing and tightening the wall elements
- 3 Hole for allowing the clamping bolt to fix the wall to the floor
- 4 WALCO® 80 base plate VS D22 increases the stability and the strength of the system
- 5 Hex screw 10x60 mm
- 6 Spring washer M16
- 7 WALCO® 80 with M16 welded sleeve
- 8 Oblong holes for vertical or horizontal adjustments (optional)



WALCO BOLT

Dimensions - WALCO® BOLT D20 L100

Art.-No.K909

(Dimensions in mm)

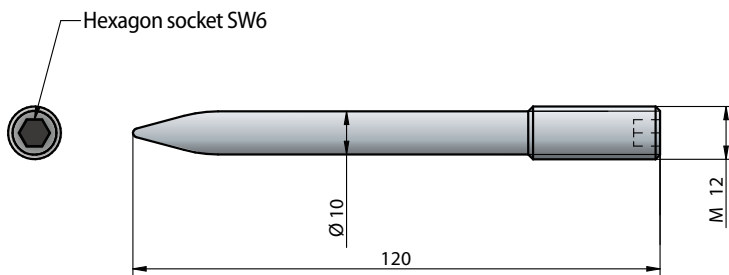
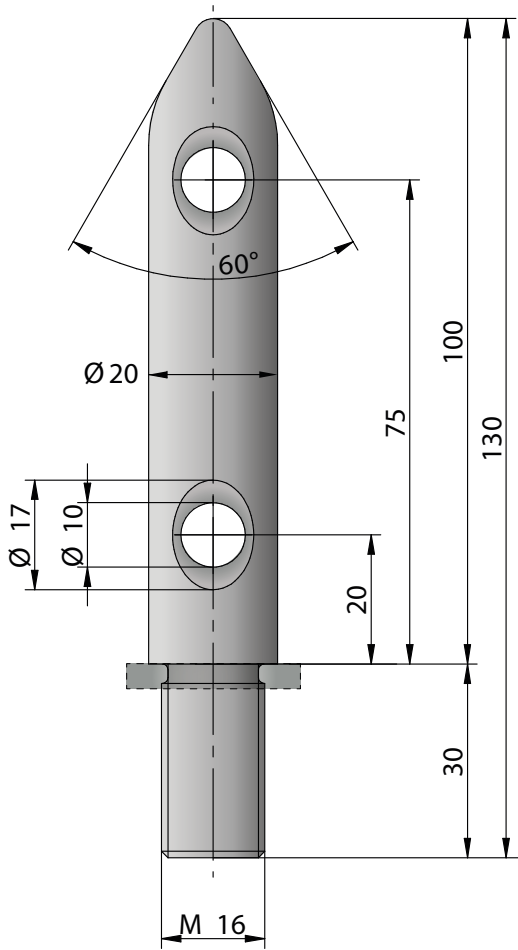

Technical details - WALCO® BOLT A130

Art.-No.K900

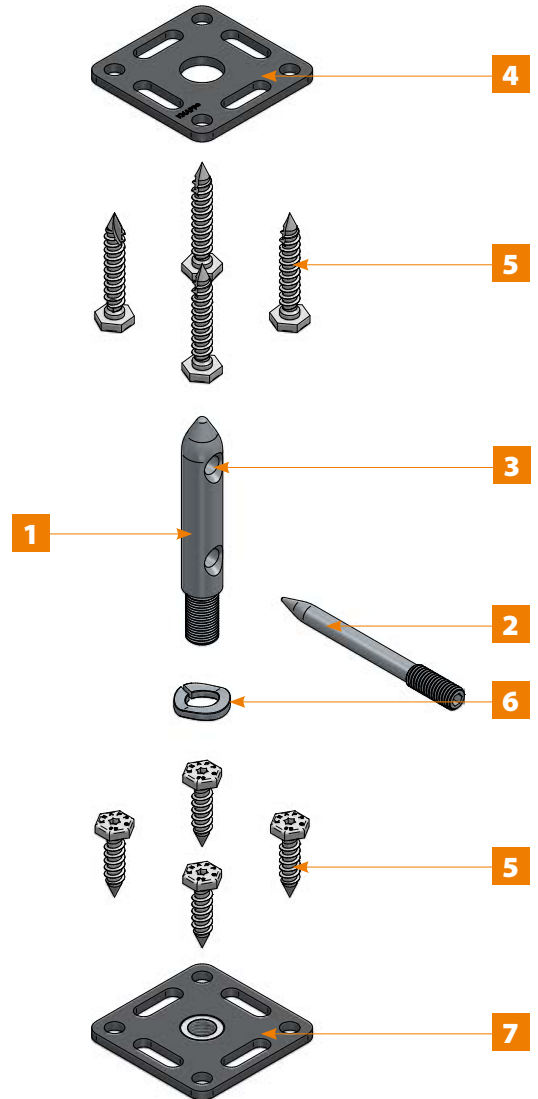

Pos.	Description	Art.-No.
1	Ø20 mm bolt	K909
2	M12x120 clamping bolt	K908
4	WALCO® 80 VS D22 base plate	K712
5	Hex screw 10x60 mm	Z551
6	Spring washer M16	Z895
7	WALCO® 80 with M16 welded sleeve	K712/V

Installation options

(Dimensions in mm)

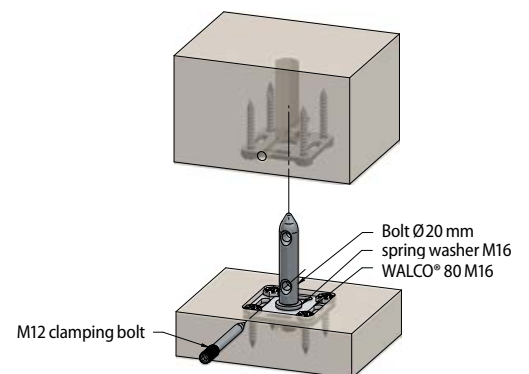
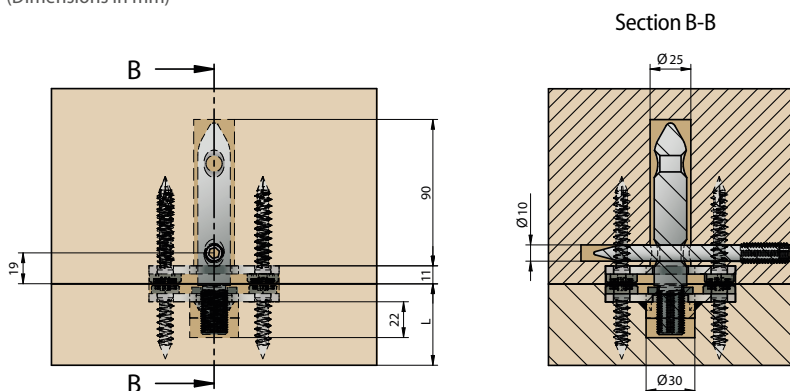

WALCO® BOLT Single D20

WALCO® BOLT B130

Art.-No.K902

(Dimensions in mm)

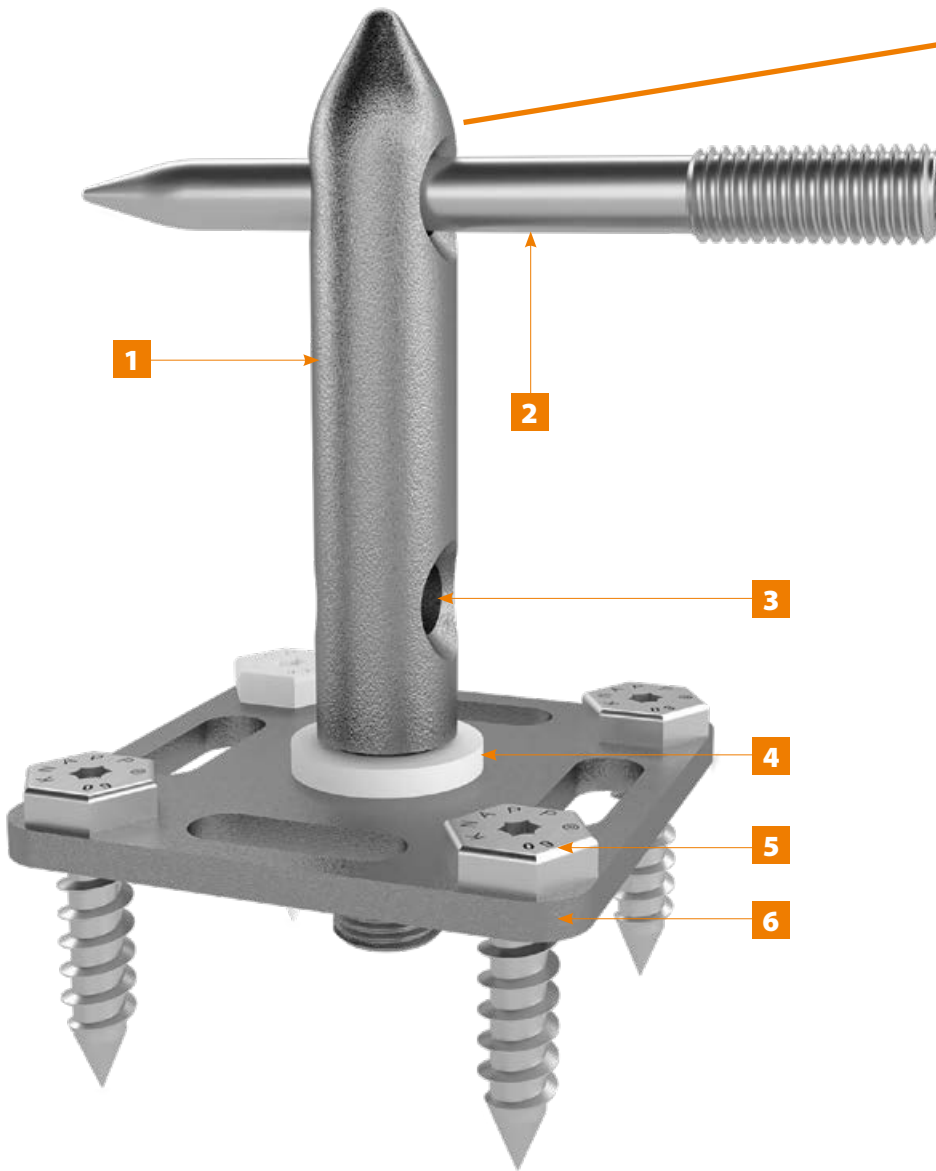

Example :
WALCO BOLT B130 wall to wall connection.

- 1** Ø20 mm bolts for anchoring and connecting wall elements
- 2** Clamping bolt for securing and tightening the wall elements
- 3** Alternative hole for clamping bolt positioning
- 4** Spring washer M16
- 5** Hex screw 10x60 mm
- 6** WALCO® 80 with M16 welded sleeve

Installation options

(Dimensions in mm)

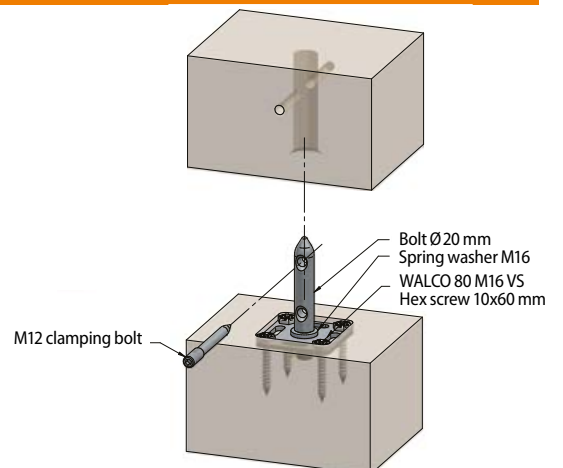
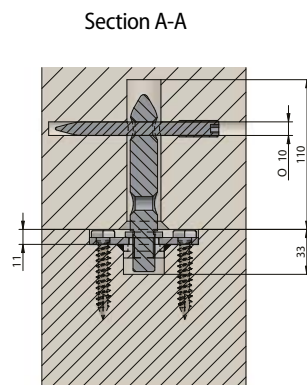
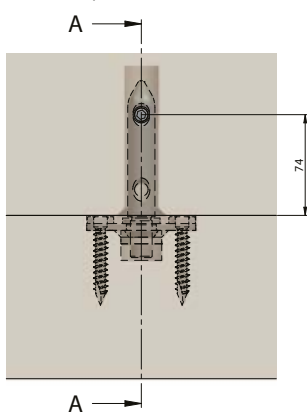

Dimensions - WALCO® BOLT B130

Art.-No.K902

(Dimensions in mm)

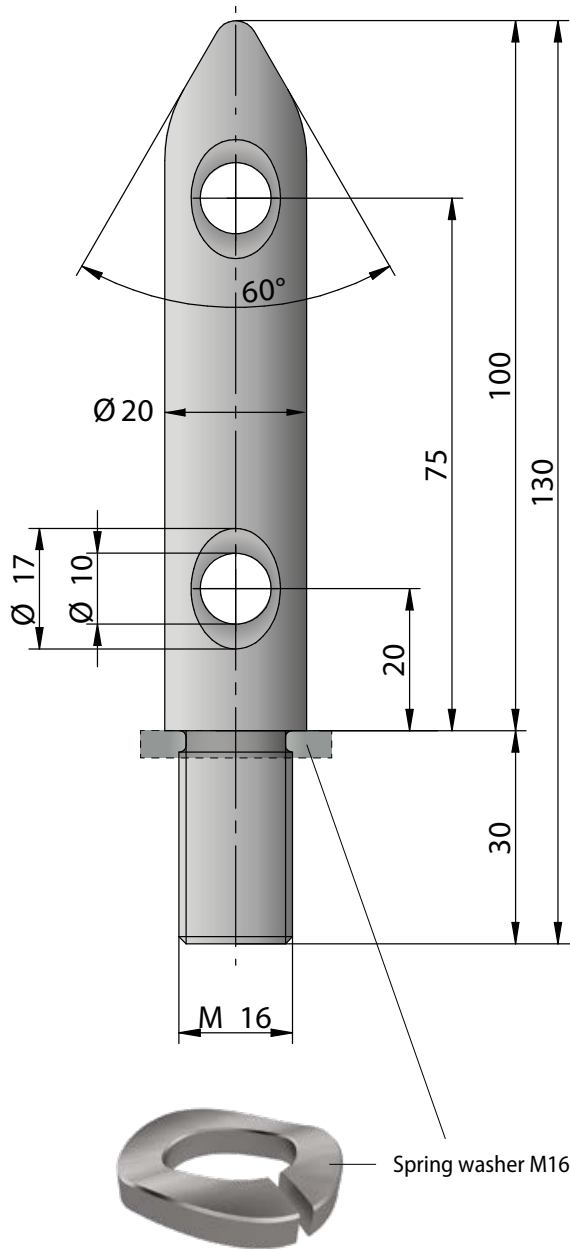

Technical details - WALCO® BOLT B130*

Art.-No.K902



Pos.	Description	Art.-No.
1	Ø 20 mm bolt	K909
2	M12x120 clamping bolt	K908
3	Clamping bolt alternative bore	–
4	Spring washer M16	Z895
5	Hex screw 10x60 mm	Z551
6	WALCO® 80 with M16 welded sleeve	K712/V

WALCO® BOLT D20

Accessories

Art.-No.Z551

Hexagon head self tapping screw 10x60



Art.-No.Z895

Spring washer M16



Application: to screw in WALCO® 80 base plate.

Spring washer M16 for fixing the position of the bolt.

WALCO® BOLT simple D20

WALCO® BOLT C130

Art.-No.K901

(Dimensions in mm)



Example :
Jonction mur-mur avec WALCO BOLT B130

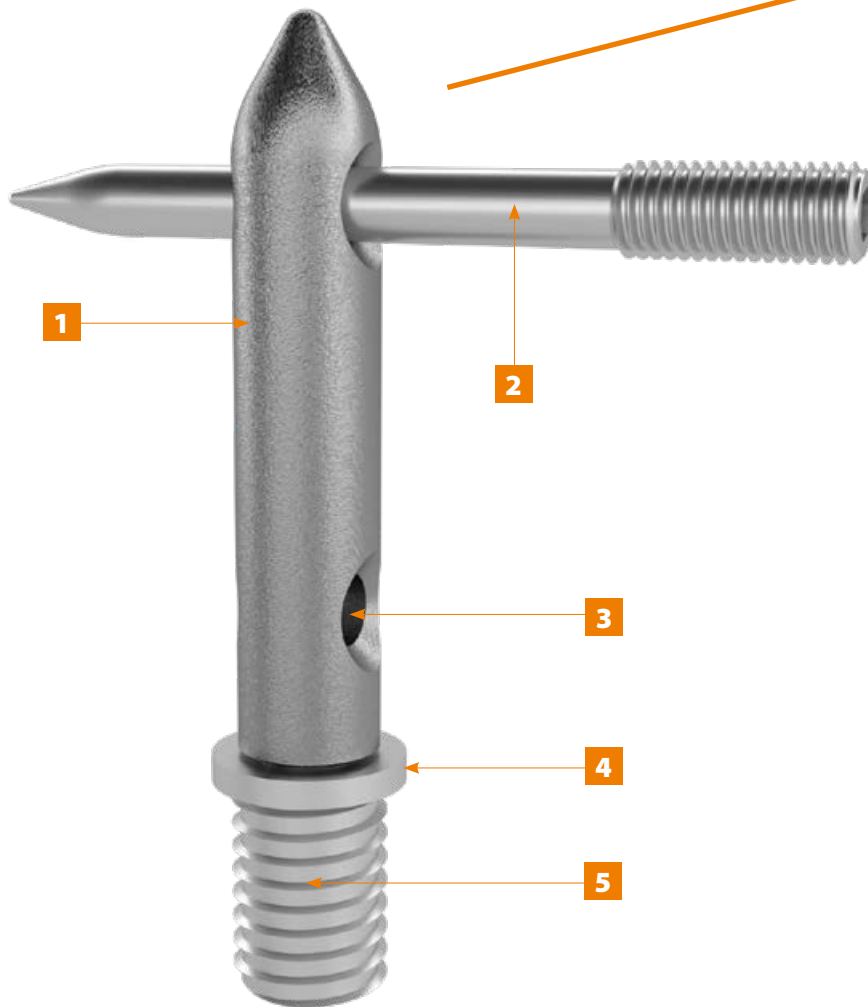

- 1** Ø20 mm bolts for anchoring and connecting wall elements
- 2** Clamping bolt for securing and tightening the wall elements
- 3** Clamping bolt for securing and tightening the wall elements
- 4** Spring washer M16
- 5** Insert for screwing the bolt system into wooden components

Installation options

(Dimensions in mm)

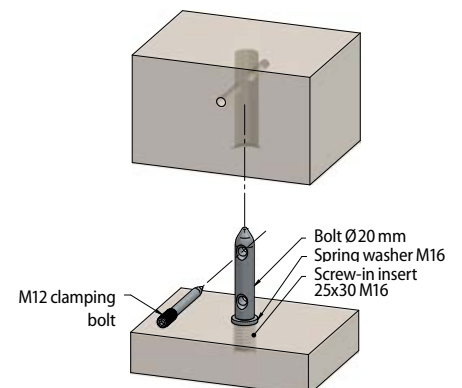
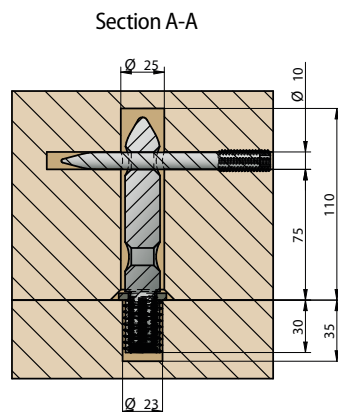
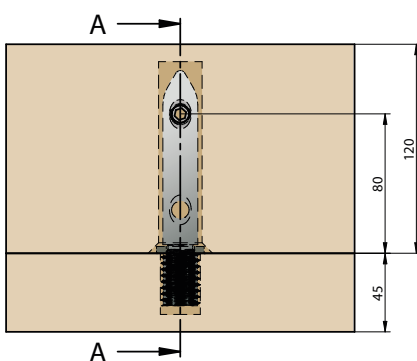

Dimensions - WALCO® BOLT C130

Art.-No.K901

(Dimensions in mm)

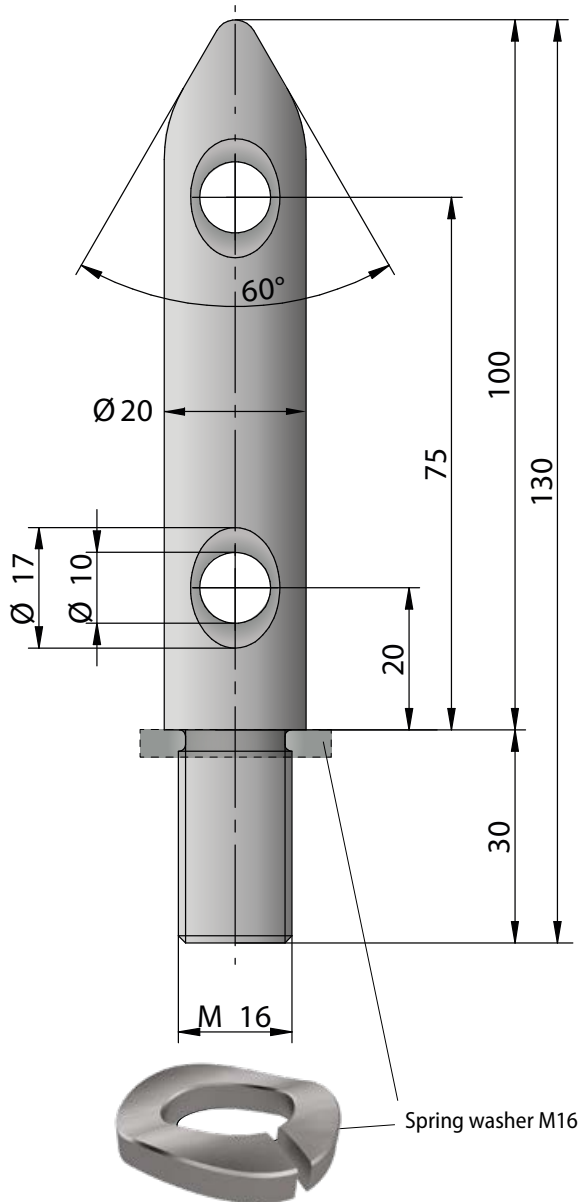

Technical details - WALCO® BOLT C130

Art.-No.K901



Pos.	Description	Art.-No.
1	Ø 20 mm bolt	K909
2	M12x120 clamping bolt	K908
3	Clamping bolt bore	-
4	Spring washer M16	Z895
5	Insert D25/40	Z644

WALCO® BOLT D20

Parts and accessories

Art.-No.K908

M12x120 clamping bolt



Application: to fix and clamp WALCO® Bolt to the wooden elements.

Art.-No.Z644

Insert type BL 25x40



Art.-No.Z561/100

Insert type BL 25x100 (optional)



Application: pto screw the bolt into wood.

WALCO® BOLT

Performance data

WALCO BOLT A130: 4 screws 10x60 (wall) and 4 screws 10x60 (w/floor)				Tensile characteristic resistance values $F_{1,Rk}$ [kN]	Tensile design value $F_{1,Rd}$ [kN]				
Element	Timber grade	Dimensions [mm]	Screwdriving		$k_{mod}=0,6$	$k_{mod}=0,7$	$k_{mod}=0,8$	$k_{mod}=0,9$	$k_{mod}=1,0$
Wall	CLT (350 kg/m ³)	100 (3S)	90°	21.00	9.69	11.31	12.92	14.54	16.15
Floor	CLT (350 kg/m ³)	≥ 120 (5S)	90°						
Wall	CLT (400 kg/m ³)	100 (3S)	90°	23.37	10.79	12.58	14.38	16.18	17.98
Floor	CLT (400 kg/m ³)	≥ 120 (5S)	90°						
Wall	CLT (350 kg/m ³)	100 (5S)	0°	6.30	2.91	3.39	3.88	4.36	4.85
Floor	CLT (350 kg/m ³)	≥ 120 (5S)	90°						
Wall	CLT (400 kg/m ³)	100 (5S)	0°	7.01	3.24	3.77	4.31	4.85	5.39
Floor	CLT (400 kg/m ³)	≥ 120 (5S)	90°						

0° butt screw connection

90° through-wire screw connection

WALCO® BOLT A130

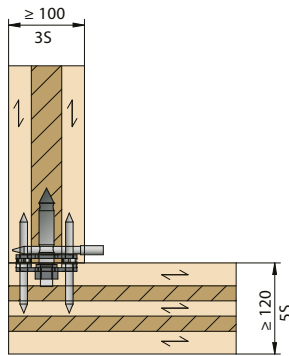

90° through-wire screw connection on CLT

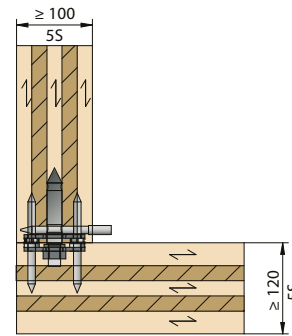

0° butt screw connection on CLT

WALCO BOLT B130 and C130 : Clamping bolt (wall/joist) and B130, C130 bolt (floor)				Tensile characteristic resistance values $F_{1,Rk}$ [kN]	Tensile design value $F_{1,Rd}$ [kN]				
Element	Timber grade	Dimensions [mm]	Screwdriving		$k_{mod}=0,6$	$k_{mod}=0,7$	$k_{mod}=0,8$	$k_{mod}=0,9$	$k_{mod}=1,0$
Wall	CLT (350 kg/m ³)	100 (3S)	90°	7.20	3.32	3.88	4.43	4.99	5.54
Floor	CLT (350 kg/m ³)	≥ 120 (5S)	90°						
Wall	CLT (400 kg/m ³)	100 (3S)	90°	7.76	3.58	4.18	4.78	5.37	5.97
Floor	CLT (400 kg/m ³)	≥ 120 (5S)	90°						
Wall	GL24c	100	90°	7.37	3.40	3.97	4.54	5.10	5.67
Floor	CLT (350 kg/m ³)	≥ 120 (5S)	90°						
Wall	GL24h	100	90°	7.59	3.50	4.09	4.67	5.26	5.84
Floor	CLT (400 kg/m ³)	≥ 120 (5S)	90°						

0° butt screw connection

90° through-wire screw connection

WALCO® BOLT B130

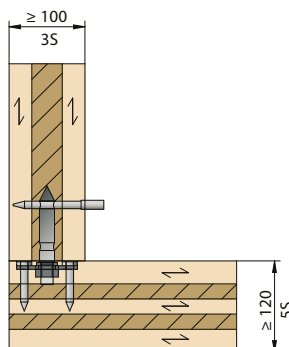

WALCO® BOLT C130

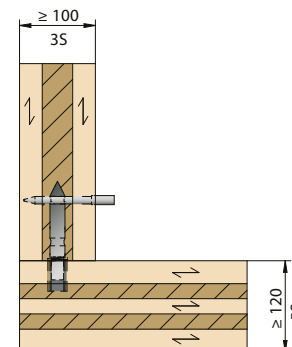

Anchoring system

Anchoring of timber-frame walls and posts, up to 19,6 kN*

- | Timber width from 100 mm
- | Highly advanced production prefabrication
- | Anchoring by simply interlocking the wall elements
- | Very strong anchoring
- | Disassembly and reassembly without damage
- | Use of the system for lifting

WALCO[®] PIPE

Available in 2 sizes.

The load-bearing capacity values of the connectors are available on our website in the research and design section.

* Tensile characteristic values F_{1,Rk} for WALCO PIPE C300 on CLT 400 Kg/m³, in accordance with ETA-23/0670 (2023/09/25).



© WoodRocks Bau GmbH

WALCO® PIPE

- ! Stable and invisible connections for timber frame and CLT walls
- ! Post to post connection solution
- ! Precise positioning of wall elements in combination with WALCO® V
- ! Can be dismantled and reassembled thanks to the thread on the needle screw
- ! Lifting aid for wall units
- ! Service class 1 and 2



© WoodRocks Bau GmbH

Installation example :
Wall to wall connection with Pipe System.

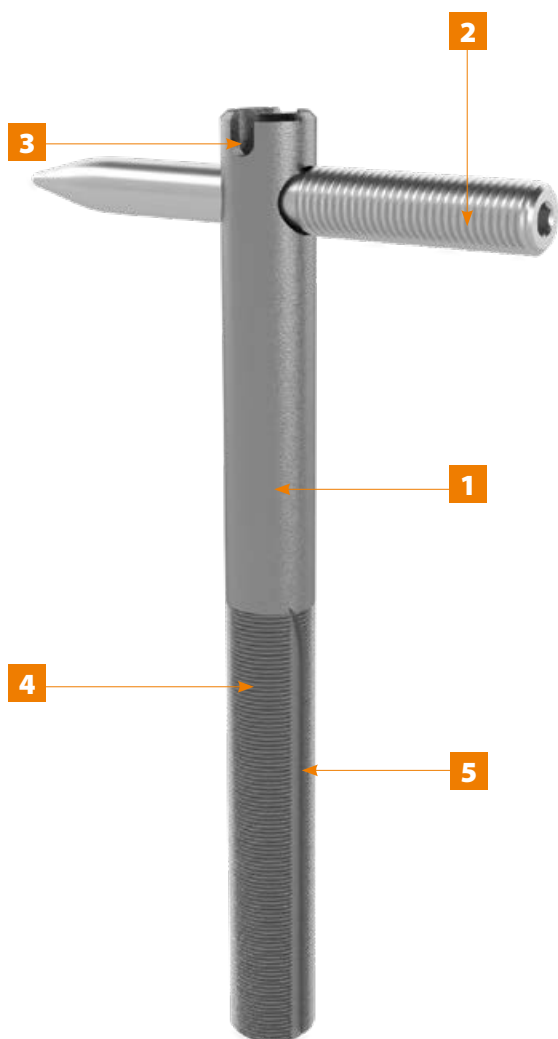

- 1 Pipe connector for the connection of posts and wall elements.
- 2 Clamping bolts for securing and tightening the wall element.
- 3 Milled recesses to accommodate the insertion aid.
- 4 M28 thread.
- 5 Two-sided slit for easier screwing in.



Lifting shackle

Insertion aid



WALCO PIPE

Technical details

Art.-No.K903 and K904

(Dimensions in mm)

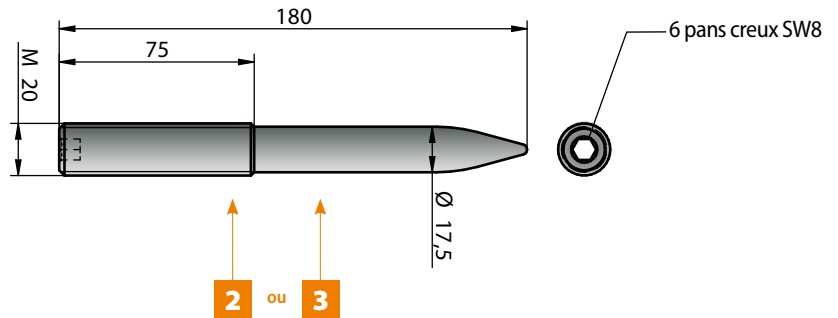
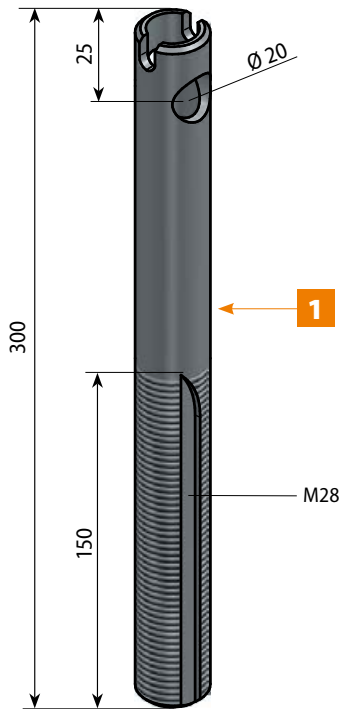

Pos.	Description	Art.-No.
1	Tube 300 M28	K905
2	Clamping bolt with thread $\varnothing 18 \times 180$	K906
3	Clamping bolt without thread $\varnothing 18 \times 180$	K907

N.B. : mèches adaptées disponibles sur demande.

Installation example

Art.-No.K903 and K904

Art.-No.K911 and K906

(Dimensions in mm)

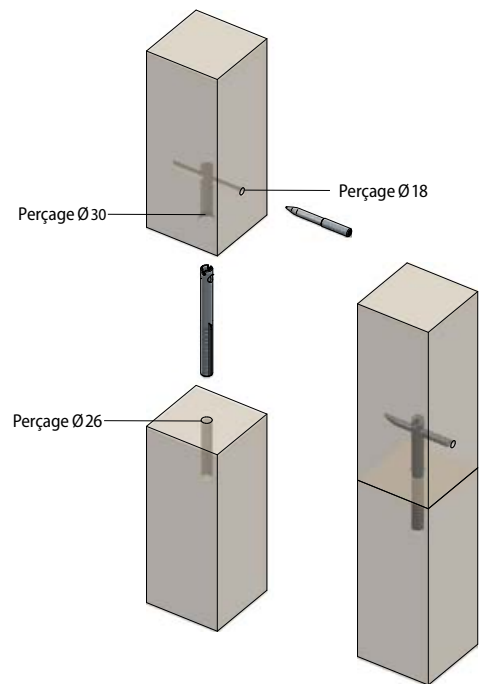
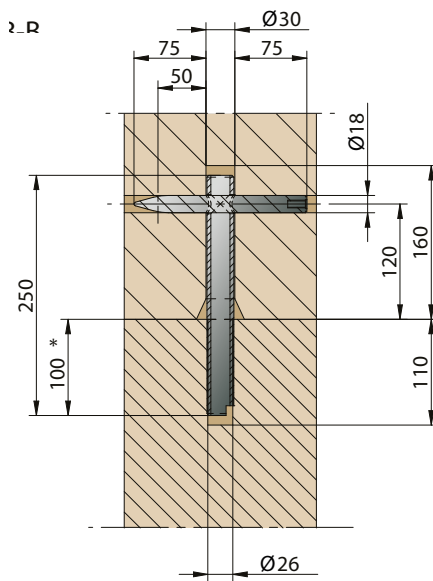
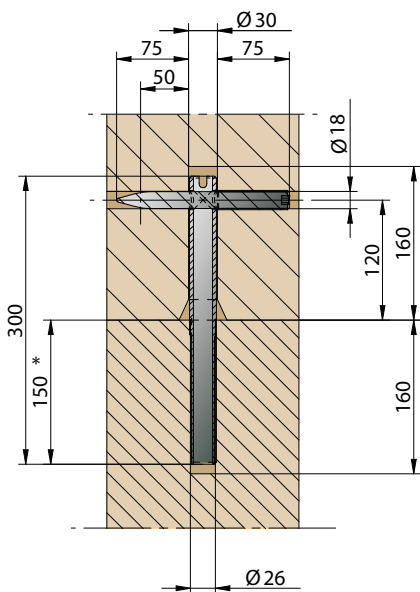

* ... La résistance des composants peut être adaptée en fonction de la profondeur de vissage du tube dans l'élément bois. Pas de filetage 3 mm.

WALCO® PIPE M28

Composants and accessoires

Art.-No.K906

Clamping bolt with thread D18x180

Art.-No.K907

Clamping bolt without thread D18x180



Application: fixing and clamping WALCO® PIPE with timber elements.

Art.-No.K487

Locking bolt



+ Safety ball pin (Art.-No.K487/SET)

Art.-No.K488

Lifting shackle



Application: fixing WALCO® PIPE

Lifting timber components with WALCO® PIPE

WALCO® PIPE

Tensile resistance values F_1

WALCO PIPE	Element	Timber grade	Dimensions [mm]	Screwdriving	Tensile characteristic resistance values $F_{1,Rk}$ [kN]	Tensile design value $F_{1,Rd}$ [kN]				
						$k_{mod}=0,6$	$k_{mod}=0,7$	$k_{mod}=0,8$	$k_{mod}=0,9$	$k_{mod}=1,0$
C250	Wall	CLT (350 kg/m ³) NH C24	100 (3S) 80x180	0°	14.00	6.46	7.54	8.62	9.69	10.77
	Floor	CLT (350 kg/m ³) NH C24"	140 (5S) 120x180	90°						
C250	Wall	CLT (400 kg/m ³)	100 (3S)	0°	15.58	7.19	8.39	9.59	10,79	11.98
	Floor	CLT (400 kg/m ³)	140 (5S)	90°						
C250	Post base	GL24h	80x180	0°	9.07	4.19	4.88	5.58	6.28	6.98
	Post top	GL24h	80x180	0°						
C300	Wall	CLT (350 kg/m ³) NH C24"	100 (3S) 80x180	0°	18.10	8.35	9.75	11.14	12.53	13.92
	Floor	CLT (350 kg/m ³) NH C24"	200 (5S) 180x180	90°						
C300	Wall	CLT (400 kg/m ³)	100 (3S)	0°	19.62	9.06	10.56	12.07	13.58	15.09
	Floor	CLT (400 kg/m ³)	200 (5S)	90°						
C300	Post base	GL24h	80x180	0°	13.60	6.28	7.32	8.37	9.42	10.46
	Post top	GL24h	80x180	0°						

0° butt screw connection

90° through-wire screw connection

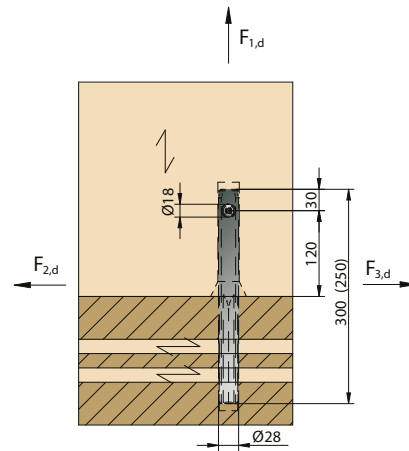
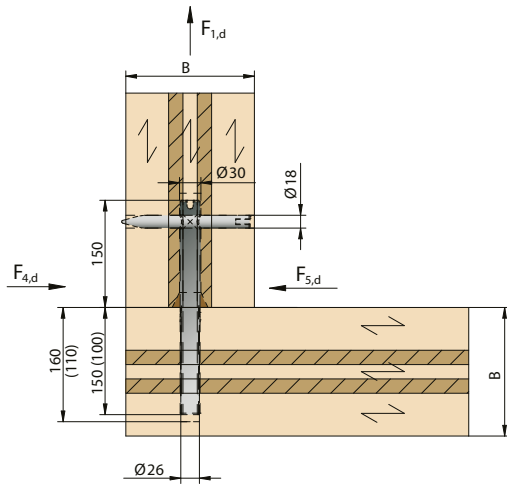
Shear strength values F_2 / F_3 , in the plane of the wall

WALCO PIPE	Element	Timber grade	Dimensions [mm]	Screwdriving	Tensile characteristic resistance values $F_{2,Rk} / F_{3,Rk}$ [kN]	Tensile design value $F_{2,Rd} / F_{3,Rd}$ [kN]				
						$k_{mod}=0,6$	$k_{mod}=0,7$	$k_{mod}=0,8$	$k_{mod}=0,9$	$k_{mod}=1,0$
C250	Wall	CLT (350 kg/m ³)	100 (3S)	0°	11.85	5.47	6.38	7.29	8.20	9.12
	Floor	CLT (350 kg/m ³)	140 (5S)	90°						
C250	Wall	CLT (400 kg/m ³)	100 (3S)	0°	12.89	5.95	6.94	7.93	8.92	9.92
	Floor	CLT (400 kg/m ³)	140 (5S)	90°						
C300	Wall	CLT (350 kg/m ³)	100 (3S)	0°	14.10	6.51	7.59	8.68	9.76	10.85
	Floor	CLT (350 kg/m ³)	200 (5S)	90°						
C300	Wall	CLT (400 kg/m ³)	100 (3S)	0°	15.56	7.18	8.38	9.58	10.77	11.97
	Floor	CLT (400 kg/m ³)	200 (5S)	90°						

0° butt screw connection

90° through-wire screw connection

Shear strength values F_4 / F_{S_r} perpendicular to the plane of the wall

WALCO PIPE	Element	Timber grade	Dimensions [mm]	Screwdriving	Tensile characteristic resistance values $F_{45,Rk}$ [kN]	Tensile design value $F_{45,Rd}$ [kN]				
						$k_{mod}=0,6$	$k_{mod}=0,7$	$k_{mod}=0,8$	$k_{mod}=0,9$	$k_{mod}=1,0$
C250	Wall	CLT (350 kg/m ³)	100 (3S)	0°	8.42	3.89	4.53	5.18	5.83	6.48
	Floor	CLT (350 kg/m ³)	140 (5S)	90°						
C250	Wall	CLT (400 kg/m ³)	100 (3S)	0°	8.42	3.89	4.53	5.18	5.83	6.48
	Floor	CLT (400 kg/m ³)	140 (5S)	90°						
C300	Wall	CLT (350 kg/m ³)	100 (3S)	0°	8.42	3.89	4.53	5.18	5.83	6.48
	Floor	CLT (350 kg/m ³)	200 (5S)	90°						
C300	Wall	CLT (400 kg/m ³)	100 (3S)	0°	8.42	3.89	4.53	5.18	5.83	6.48
	Floor	CLT (400 kg/m ³)	200 (5S)	90°						

0° butt screw connection

90° through-wire screw connection

The position is decisive for the justification of the $F_{45,Rk}$ load:

$$F_{45,Rk} = \min \left\{ \begin{array}{l} F_{23,Rk} \\ \frac{k_v \cdot f_{v,k} \cdot b \cdot h_{ef}}{1,5} \end{array} \right.$$

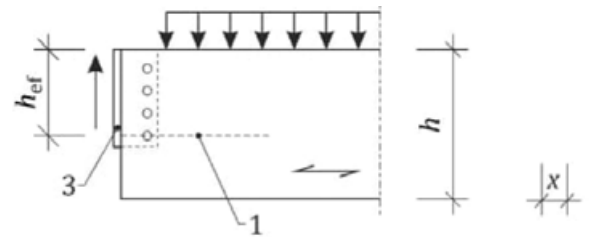

Tensile and shear strength values for the WALCO® PIPE lifting device

WLL_{tension} (WALCO Lifting Load Tension) Tensile strength of the WALCO® PIPE lifting device

WALCO PIPE	Element	Timber grade	Dimensions [mm]	Screwdriving	WALCO® PIPE pull-off	Load-splitting
					WLL _{tension} [kN]	WLL _{tension} [kN]
C250	Wall	CLT (350 kg/m ³)	100 (3S)	0°	1.10	4.10
	Floor	CLT (350 kg/m ³)	140 (5S)	90°	3.20	
C250	Wall	CLT (400 kg/m ³)	100 (3S)	0°	1.30	4.10
	Floor	CLT (400 kg/m ³)	140 (5S)	90°	3.50	
C300	Wall	CLT (350 kg/m ³)	100 (3S)	0°	1.70	7.60
	Floor	CLT (350 kg/m ³)	200 (5S)	90°	4.80	
C300	Wall	CLT (400 kg/m ³)	100 (3S)	0°	1.90	7.60
	Floor	CLT (400 kg/m ³)	200 (5S)	90°	5.30	

0° butt screw connection

90° through-wire screw connection

The load values refer to the expert report dated 30.05.2023 (Professeur Dr.-Ing H.J. Blaß)

$$WLL_{tension} = \min \left\{ \begin{array}{l} K_{ax} \cdot 4.800 \cdot \left(\frac{\rho_k}{350} \right)^{0,8} \\ \frac{h}{4,4 \cdot (h - 150)} \cdot \left(6,5 + \frac{18 \cdot 150^2}{h^2} \right) \cdot (t_{ef} \cdot h)^{0,8} \cdot f_{t,90,k} \end{array} \right.$$

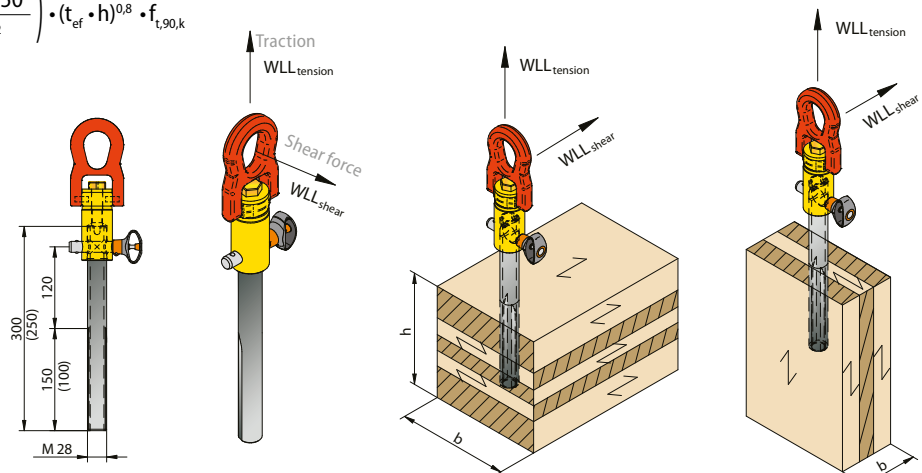

WLL_{shear} (WALCO® Lifting Tension Load) calculation example for the WALCO® PIPE lifting device

Walco Pipe:	C300		
Diameter d =	28	mm	
Length in CLT wall t ₁ =	150	mm	
Protruding length t ₂ =	165	mm	
Flow moment M _{y, Pipe, Rk} =	486000	Nmm	
CLT wall thickness h =	100	mm	
CLT wall width b =	200	mm (2 x h)	
Material:	CLT	Bois de fil	
Density ρ _k =	350	kg/m ³	
Stress angle α =	90	°	
Hole local bearing capacity f _{h,0,k} =	20,66	N/mm ²	= 0,082 x (1-0,01 x d) x ρ _k
Hole local bearing capacity f _{h,90,k} =	4,67	N/mm ²	= 0,4 x 0,082 x (1-0,01 x d) x rk / (1,35 + 0,015 x d)

Load values refer to the expert report as of 30.05.2023 (Professeur Dr.-Ing H.J. Blaß)

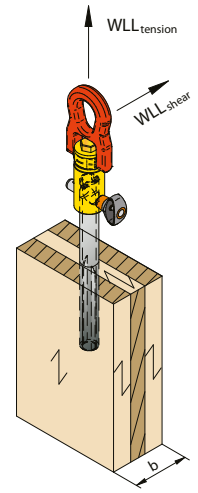
Checking the resistance of CLT to splitting using WLL_{shear} on WALCO® PIPE :

CLT wall thickness CLT h =	100	mm	
CLT wall width CLT b =	200	mm (2 x h)	
Shear strength f _{v,k} =	2	N/mm ²	
Height h _{ef} =	50	mm	
a = h _{ef} / h =	0,5		
Distance x =	215	mm	
Coefficient k _n =	6,5	(CLT)	
Reducing coefficient k _v =	0,234	(EN 1995-1-1 (Gl. 6.62))	
Shear force WLL _{shear} =	0,71	kN	= (k _v x f _{v,k} x b x h _{ef}) / 6,6
Shear force WLL _{shear} =	1,95	kN	= f _{h,90,k} x 6,36 x min {65,8 ; (165 ² + (34700 / f _{h,90,k}) ^{0,5} - 165)}

$$k_v = \min \left\{ \frac{K_n \left(1 + \frac{1,5 \cdot l^{1,5}}{\sqrt{h}} \right)}{\sqrt{h} \left(\sqrt{a(1-a)} + 0,8 \frac{x}{h} \sqrt{\frac{1}{a} - a^2} \right)} \right.$$

Min. shear. WLL_{shear} = 0,71 kN

$$WLL_{shear} = \min \left\{ \frac{K_{ax} \cdot 6,36 \cdot \min \left\{ \frac{65,8}{\sqrt{165^2 + \frac{34.700}{f_{h,k}}} - 165} \right. \right.}{k_v \cdot f_{v,k} \cdot b \cdot h_{ef}} \left. \right.$$

Combined analysis:

$$\left(\frac{F_{Ed, tension}}{F_{WLL, tension}} \right)^2 + \left(\frac{F_{Ed, shear}}{F_{WLL, shear}} \right)^2 \leq 1$$

Note: to increase the WLL_{shear} load-bearing capacity on CLT, it is necessary to add full-thread screws on the face of the wall next to WALCO® PIPE. These prevent the CLT walls or floors from splitting!

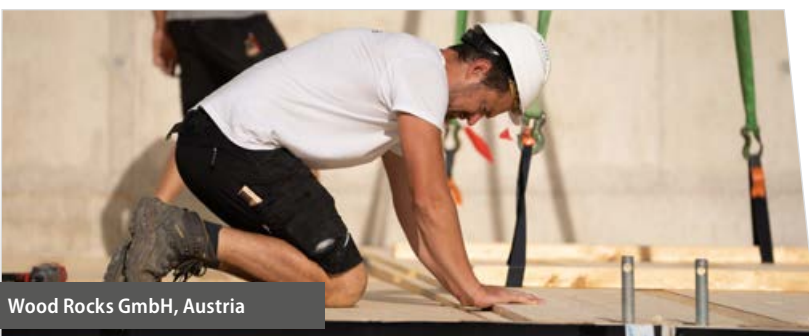
Reference project

Wood Rocks GmbH, Austria

Anchoring solution for timber walls

**L and T-shaped connector, anchoring
timber-frame walls up to 10.8 kN**

- | Prefabrication of the wall modules in the factory
- | Absorption of tensile and shear forces through the anchoring in the wall axis
- | Stable fastening of the walls by means of tie rods and angle bracket
- | Space-saving transport
- | Easy adjustment of the walls on site
- | Short assembly time of up to 15-20 minutes time saving per wall element (compared with conventional conventional bracket solutions)

WALCO[®] L and T

Available in 1 size and 2 versions.

Design values are available on our website under Planer Service.

Valeurs de résistance WALCO[®] L and T suivant ETA 10-0189 (2022/08/25).

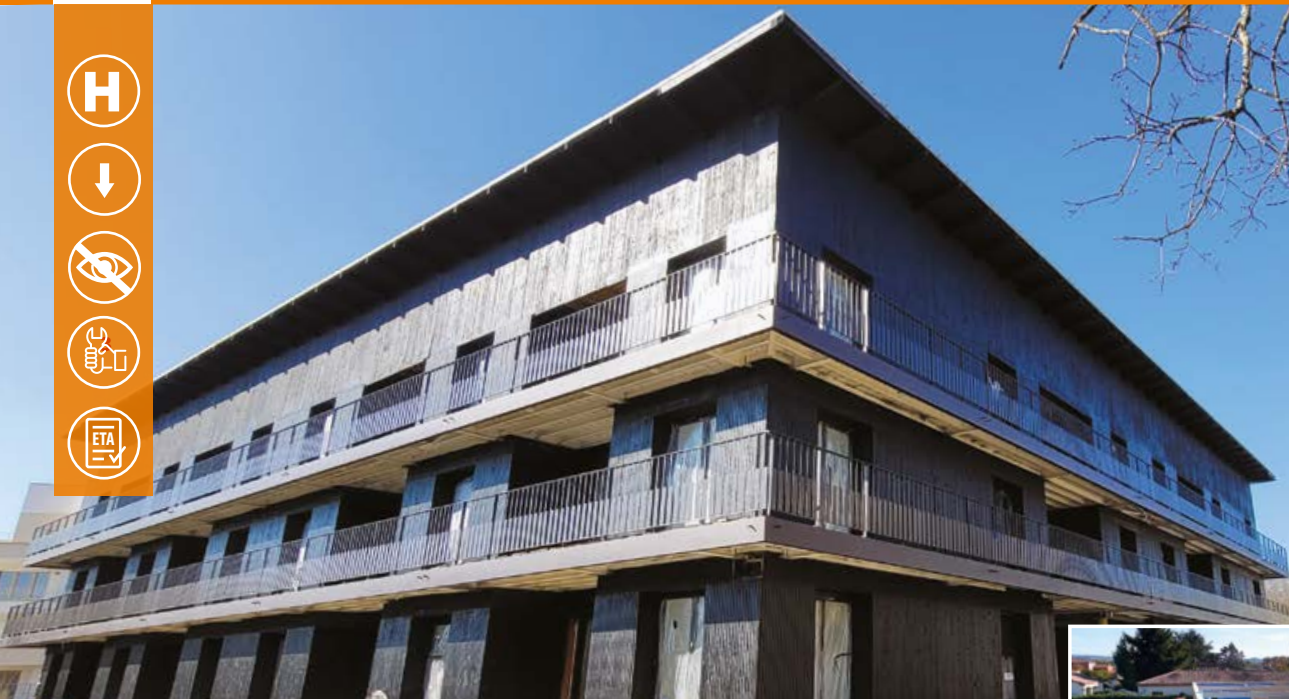

Installation example: Mounted on wall element.

WALCO® L and T

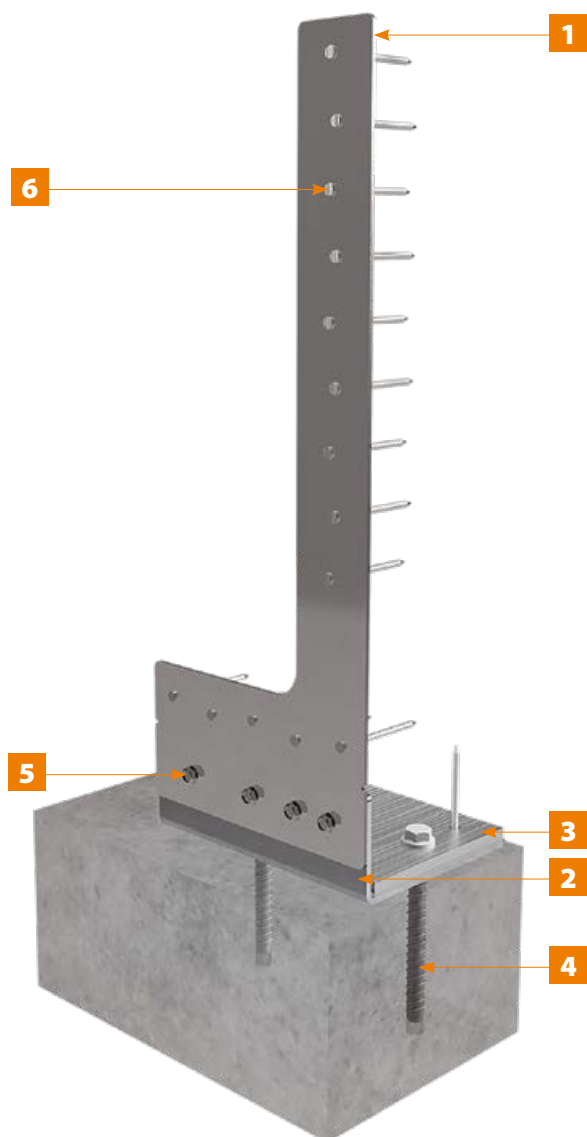

- 1** Hot-dip galvanised 3 mm sheet steel. Silver finish.
- 2** 4 mm galvanised steel anchor bracket
- 3** 10 mm Reinforcement pressure plate to ensure very high load bearing capacity
- 4** Concrete screw 12x130 requires a small drilling depth
- 5** Self-tapping hexagonal screw M8x25 for force-locking fastening and backlash-free connection.
- 6** Ring shank connecting nails 4x75 for quick processing with nailing equipment

Can be combined with wall connector WALCO® V 60/80



Our Planner service does not replace approval by an authorised structural engineer.



PLANNER SERVICE

WALCO® L

Tensile load values $F_{1,Rd}$ for tension anchor WALCO® L with fischer ULTRACUT FBS II concrete screw

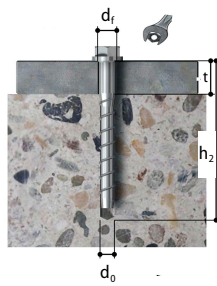
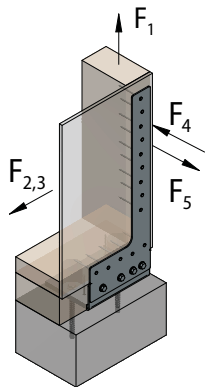

FBS II 12x130 70/55/30 US, galvanised steel	
Drill diameter d_0	= 12 mm
Drill depth h_2	= 140 mm
Calculated anchoring depth h_{ef}	= 81 mm
Installation depth h_{nom}	= 100 mm
Minimum edge distance $c_{2,min}$	= 73 mm
Reinforcement plate thickness t	= 10+4 = 14 mm
Approval:	ETA-15/0352, Option 1

KNAPP® connector	Minimum cross-section Stud [mm]	Cladding [mm]	Design values in NH C24 and concrete C20/25		Design values in NH C24 and concrete C25/30	
			Max. tensile load $F_{1,Rd}$ [kN] LDC: short	Max. tensile load $F_{1,Rd}$ [kN] LDC: short/very short	Max. tensile load $F_{1,Rd}$ [kN] LDC: short	Max. tensile load $F_{1,Rd}$ [kN] LDC: short/very short
WALCO® L 9 Ring shank nails 4x75 in stud 5 Ring shank nails 4x75 in sill plate 4 Hexagonal screws M8x25 2 Concrete screws 12x130 *	80x145 SWD C24	12 mm OSB 3 / OSB 4 Chipboard	16,84	17,31	16,84	17,31
			$F_{B,t,Rd} = 20,00$	$F_{B,t,Rd} = 20,00$	$F_{B,t,Rd} = 22,30$	$F_{B,t,Rd} = 22,30$
	80x145 SWD C24	15 mm OSB 3 / OSB 4 Chipboard	17,20	17,31	17,20	17,31
			$F_{B,t,Rd} = 20,00$	$F_{B,t,Rd} = 20,00$	$F_{B,t,Rd} = 22,30$	$F_{B,t,Rd} = 22,30$
80x145 SWD C24	18 mm OSB 3 / OSB 4 Chipboard	17,30	17,31	17,20	17,31	
		$F_{B,t,Rd} = 20,00$	$F_{B,t,Rd} = 20,00$	$F_{B,t,Rd} = 22,30$	$F_{B,t,Rd} = 22,30$	
80x145 SWD C24	22 mm OSB 3 / OSB 4 Chipboard	16,90	17,31	17,20	17,31	
		$F_{B,t,Rd} = 20,00$	$F_{B,t,Rd} = 20,00$	$F_{B,t,Rd} = 22,30$	$F_{B,t,Rd} = 22,30$	
WALCO® L 9 Ring shank nails 4x75 in stud 5 Ring shank nails 4x75 in sill plate 4 Hexagonal screws M8x25 2 Concrete 12x130 *	80x145 SWD C24	9 mm Plywood	15,22	16,25	15,22	16,25
			$F_{B,t,Rd} = 20,00$	$F_{B,t,Rd} = 20,00$	$F_{B,t,Rd} = 22,30$	$F_{B,t,Rd} = 22,30$
	80x145 SWD C24	12 mm Plywood	15,48	16,53	15,48	16,53
			$F_{B,t,Rd} = 20,00$	$F_{B,t,Rd} = 20,00$	$F_{B,t,Rd} = 22,30$	$F_{B,t,Rd} = 22,30$
	80x145 SWD C24	15 mm Plywood	15,54	16,57	15,54	16,57
$F_{B,t,Rd} = 20,00$			$F_{B,t,Rd} = 20,00$	$F_{B,t,Rd} = 22,30$	$F_{B,t,Rd} = 22,30$	
80x145 SWD C24	18 mm Plywood	15,51	16,52	15,51	16,52	
		$F_{B,t,Rd} = 20,00$	$F_{B,t,Rd} = 20,00$	$F_{B,t,Rd} = 22,30$	$F_{B,t,Rd} = 22,30$	
80x145 SWD C24	22 mm Plywood	15,35	16,29	15,35	16,29	
		$F_{B,t,Rd} = 20,00$	$F_{B,t,Rd} = 20,00$	$F_{B,t,Rd} = 22,30$	$F_{B,t,Rd} = 22,30$	
WALCO® L 9 Ring shank nails 4x75 in stud 5 Ring shank nails 4x75 in sill plate 4 Hexagonal screws M8x25 2 Concrete 12x130 *	80x145 SWD C24	12 mm GKB / GKF	14,74	16,09	14,74	16,09
			$F_{B,t,Rd} = 20,00$	$F_{B,t,Rd} = 20,00$	$F_{B,t,Rd} = 22,30$	$F_{B,t,Rd} = 22,30$
	80x145 SWD C24	15 mm GKB / GKF	15,91	17,31	15,91	17,31
$F_{B,t,Rd} = 20,00$			$F_{B,t,Rd} = 20,00$	$F_{B,t,Rd} = 22,30$	$F_{B,t,Rd} = 22,30$	
80x145 SWD C24	18 mm GKB / GKF	17,10	17,31	17,10	17,31	
		$F_{B,t,Rd} = 20,00$	$F_{B,t,Rd} = 20,00$	$F_{B,t,Rd} = 22,30$	$F_{B,t,Rd} = 22,30$	

* The table shows the load values $F_{B,t,Rd}$ of the fischer ULTRACUT FBS II concrete screws 12x130 70/55/30 US in concrete C20/25 and C25/30. If other concrete screws are used, these load values must be adjusted and, if necessary, verified again.

Proof for the tensile load direction $F_{1,r}$: $(F_{1,Ed} / F_{1,Rd}) \leq 1,0$

Verification for tensile load in concrete anchor: $(F_{B,t,Ed} / F_{B,t,Rd}) \leq 1,0$
Tensile load in concrete anchor: $F_{B,t,Ed} = F_{1,Ed} \times k_t = F_{1,Ed} \times 1,4$

LDC	Load duration class
short	Short period (exposure shorter than one week)
short/very short	short/very short period (new LDC for wind in NA)
$F_{1,Ed}$	Rated value of the tensile load (existing tensile load from the timber stud wall)
$F_{1,Rd}$	Measurement value of the tensile load carrying capacity of the WALCO® L connector
$F_{B,t,Ed}$	Design value of the tensile load of concrete screw
k_t	Parameters for determining the axial load of the concrete screw/ concrete anchor
OSB 3 / OSB 4	According to ETA approval or DIN EN 300 or DIN EN 12369-1
Chipboard	According to ETA approval or DIN EN 312
Plywood	According to ETA approval or DIN 20000-1:2017-06 (softwood)
GKB / GKF	Gypsum plasterboards/ fiber reinforced plasterboard according to ETA

Calculation example:
WALCO® L tie rod connection is installed in an 80x145 mm NH C24 stud with 15 mm OSB planking and C20/25 concrete floor slab.

Der WALCO® L is loaded by a tensile load $F_{1,Ed} = 14$ kN (LDC: short/very short). The k_t value for the off-centre tension connection in the concrete floor slab for the WALCO® L is 1.4.

Timber stud verification: $(F_{B,t,Ed} / F_{B,t,Rd}) \leq 1,0$ $(14,0 / 17,3) = 0,81 < 1,0$
Tensile load in the concrete anchor: $F_{B,t,Ed} = F_{1,Ed} \times k_t = F_{1,Ed} \times 1,4 = 14 \times 1,4 = 19,6$ kN
Concrete anchor verification: $(F_{B,t,Ed} / F_{B,t,Rd}) \leq 1,0$ $(19,6 / 20) = 0,98 < 1,0$

The load values for the concrete anchor/concrete screw in the concrete substructure can be designed separately using a design programme, e.g. C-FIX from fischer. The WALCO® L can also be loaded and designed in other load directions $F_{2,3}$, F_4 and F_5 . These verifications with the WALCO® L load values can be found in the ETA 10-0189 approval.

WALCO® L - Anchoring connector for timber walls

WALCO® L

(Dimensions in mm)

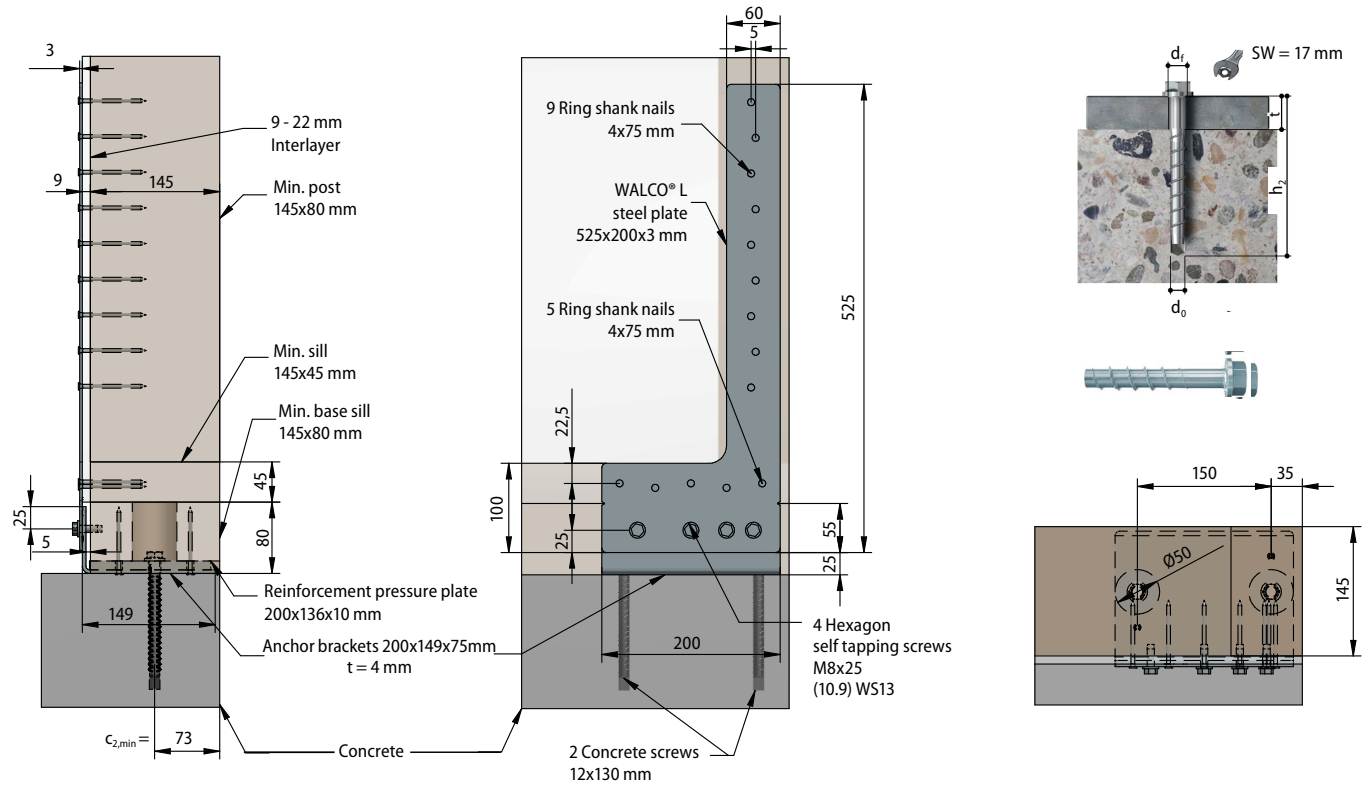

Hot-dip galvanised sheet steel - 3mm for left and right position

Anchor bracket

Art.-No. K496

Art.-No. K497

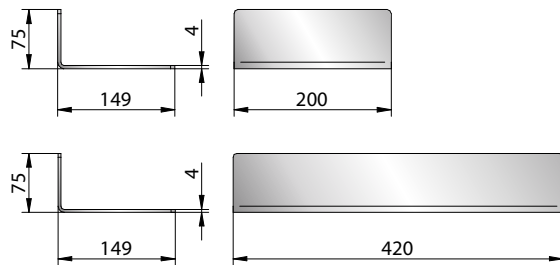
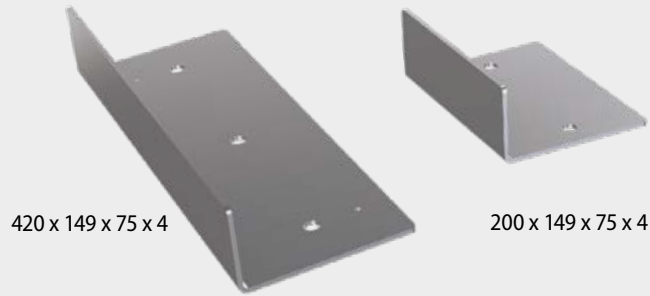

Reinforcement (pressure) plate

Art.-No. K498

Art.-No. K499

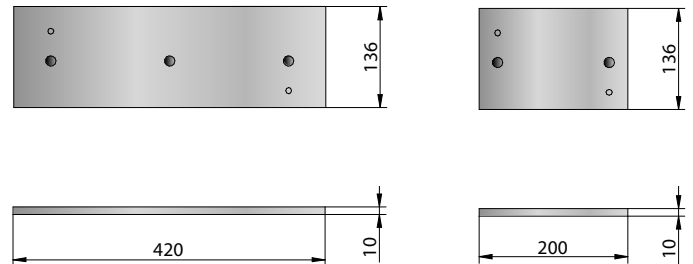
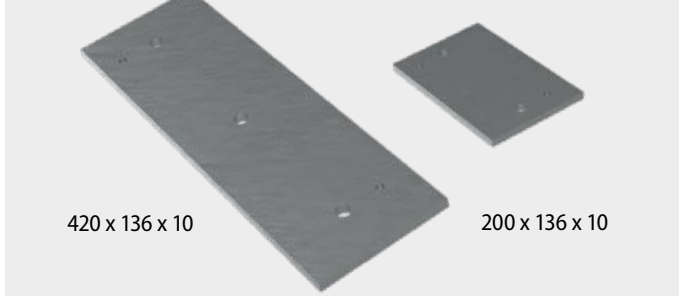

4 mm galvanized steel anchor bracket with pre-drilled fastening holes.

10 mm galvanized steel strengthening plate with pre-drilled fastening holes.



WALCO® L - Anchoring connector for timber walls

WALCO® L - Single connection

Art.-No.K495/EA

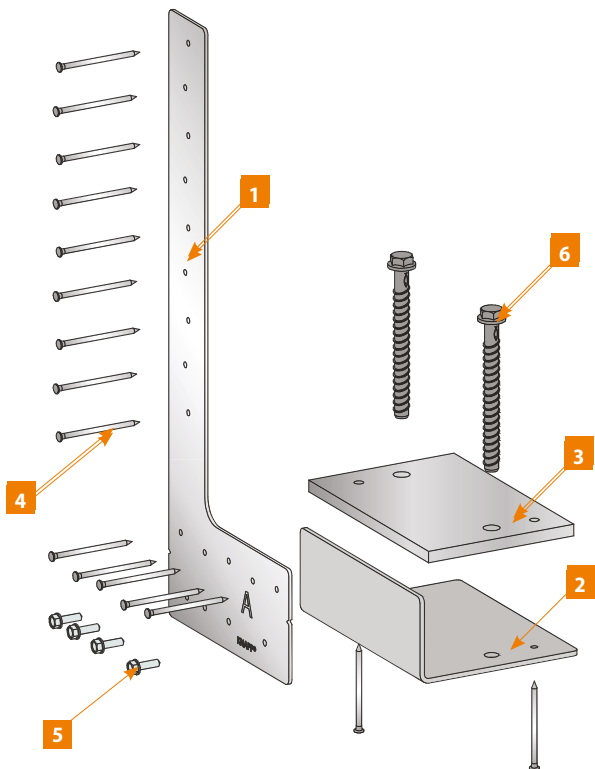

The Hexagon screws M8x25 **5**, require pre-drilling with $\varnothing 7.4$ mm into side of anchor bracket **2** for on-site assembly.



WALCO® L Set - Parts list single connector K495/EA

	Art.-No.	Description	Quantity
1	K495	Steel plate 3 mm thick	1 piece
2	K497	Anchor bracket 200/4 mm	1 piece
3	K499	Reinforcement plate 200/10 mm	1 piece
4	Z850	Ring shank nail 4x75 mm	16 pieces
5	Z648	Hexagon screw M8x25 mm	4 pieces
6	Z852	Concrete screw 12x130 mm	2 pieces

WALCO® T - Anchoring connector for timber walls

WALCO® T - Double connection

Art.-No.K495/DA

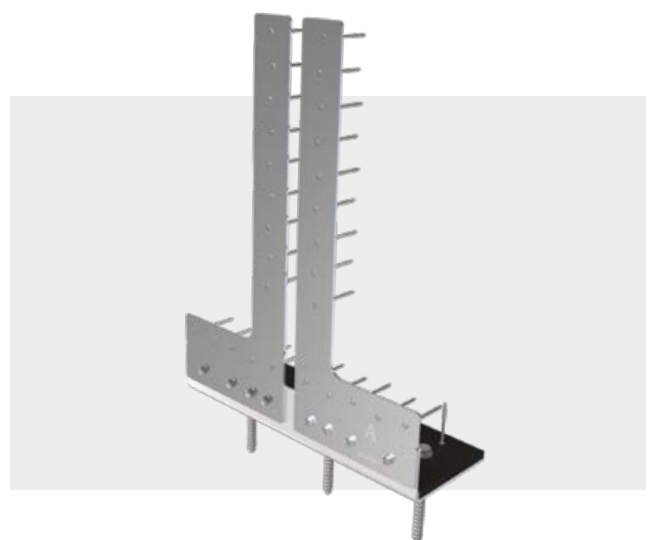
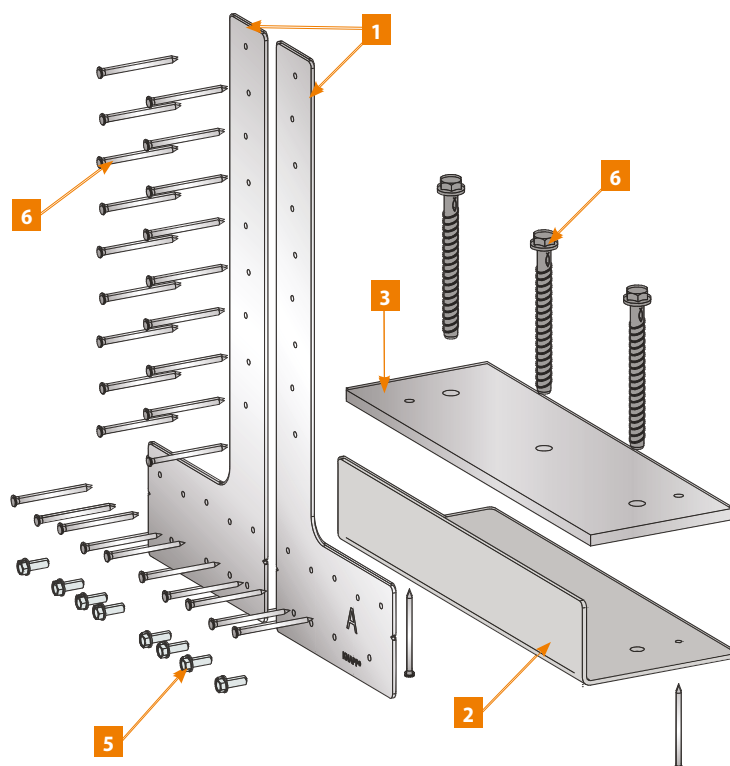

WALCO® T Set - Parts list double connector K495/DA

	Art.-No.	Description	Quantity
1	K495	Steel plate 3 mm thick	2 pieces
2	K496	Anchor bracket 420/4 mm	1 piece
3	K498	Reinforcement plate 420/10 mm	1 piece
4	Z850	Ring shank nail 4x75 mm	30 pieces
5	Z648	Hexagon screw M8x25 mm	8 pieces
6	Z852	Concrete screw 12x130 mm	3 pieces

WALCO® Installation

Prefabrication in factory

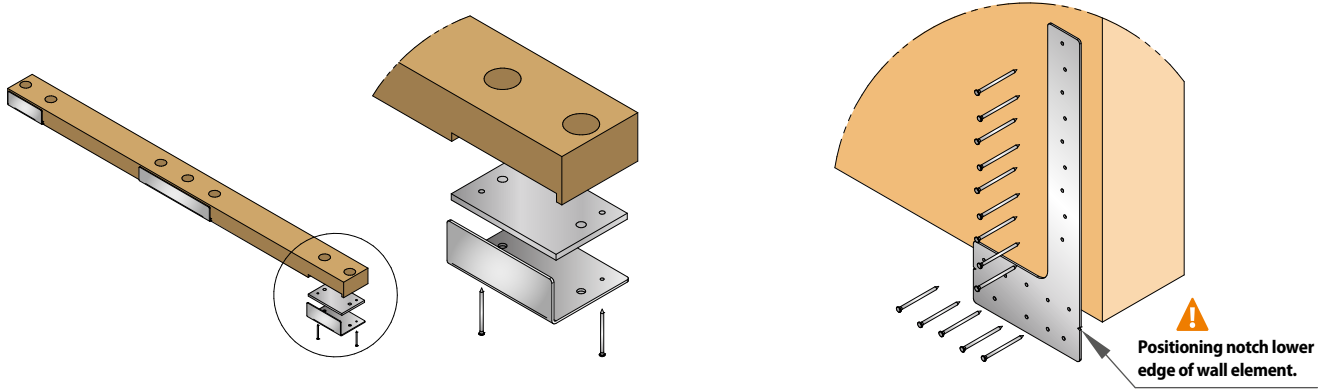

Mounting the anchor bracket with his reinforcement plate on the sill plate.

Mounting the L-shaped steel plate to wall element using the anchor nails.

Anchor bracket and sill plate installation on site

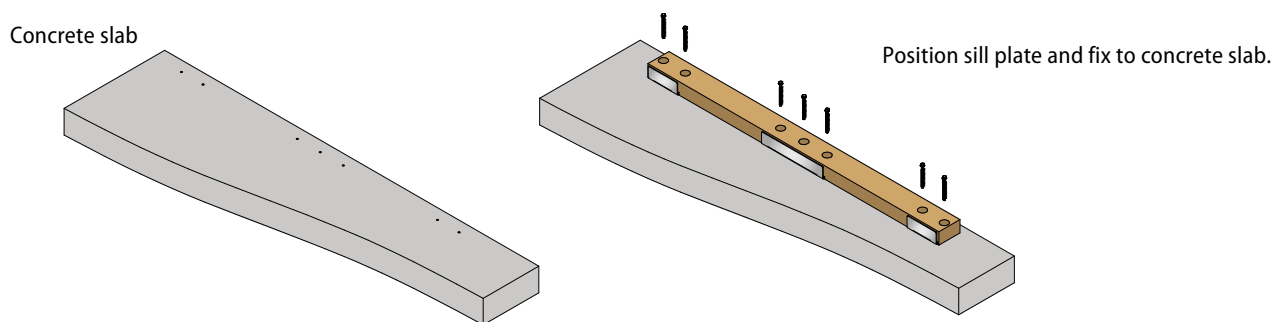

Wall installation

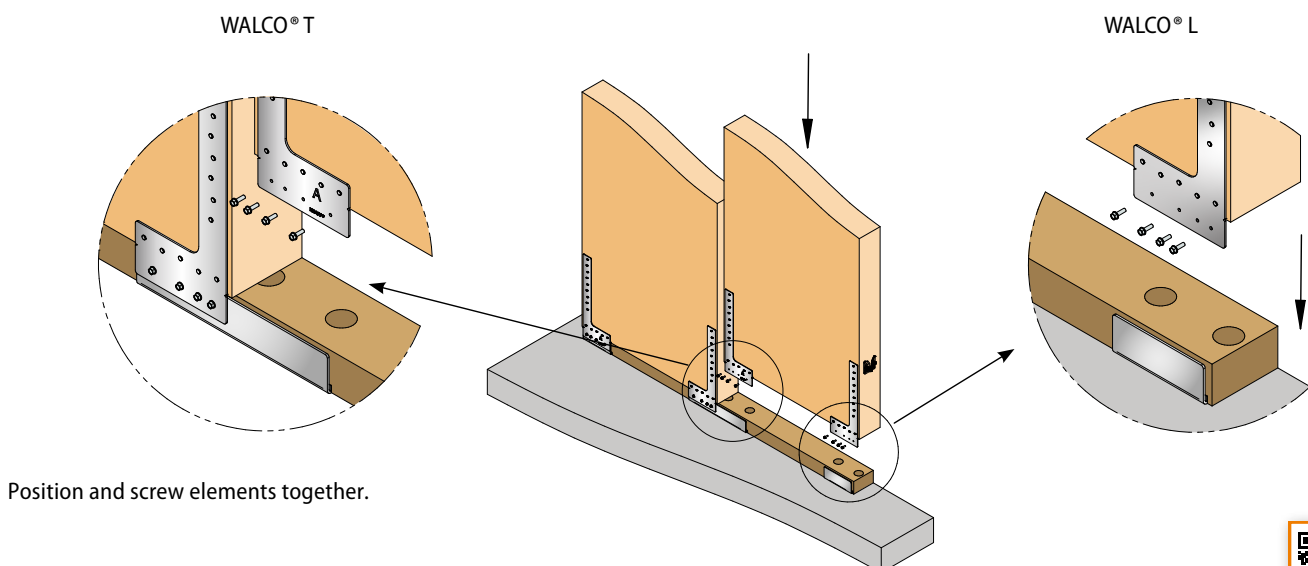

VIDEO

Angled connection cylinder

Three-dimensional screw joint cylinder up to 26 kN* for diagonal screw connection

- | Flush - no protruding connector parts
- | Readjustable
- | Dismantling and reassembly possible
- | High degree of prefabrication
- | Easy to install - simple positioning in the drill hole

T-JOINT



Available in 5 sizes and 2 versions.

The values only apply when used with original KNAPP® screws! Design values are available on our website under Planner Service.

* Characteristic value $F_{t,Rk}$ applies to T-Joint D40 W30 in CLT walls.

H

B



T-JOINT

- ▮ **Applications:** for flush 30° and 45° inclined screw connections, for bending resistant connections, floor connections and tension and wall joints as well as straight and angled connections.
- ▮ **Connection:** BSH, CLT, BauBuche, solid structural timber, MHM (solid timber wall), steel and timber tension joints.
- ▮ **Areas of application:** Ideal for timber construction, house building, pergola, carport and tensile force transmission in combination with steel ties for rigid connections (rafters of roof overhangs), timber stud walls and additional fastening of wooden panels of cantilevered canopies.
- ▮ **Service class 1, 2 and 3.**



© Greinwald (2)

Installation example: T-JOINT D20
Hellabrunn Wildlife Park, Germany.

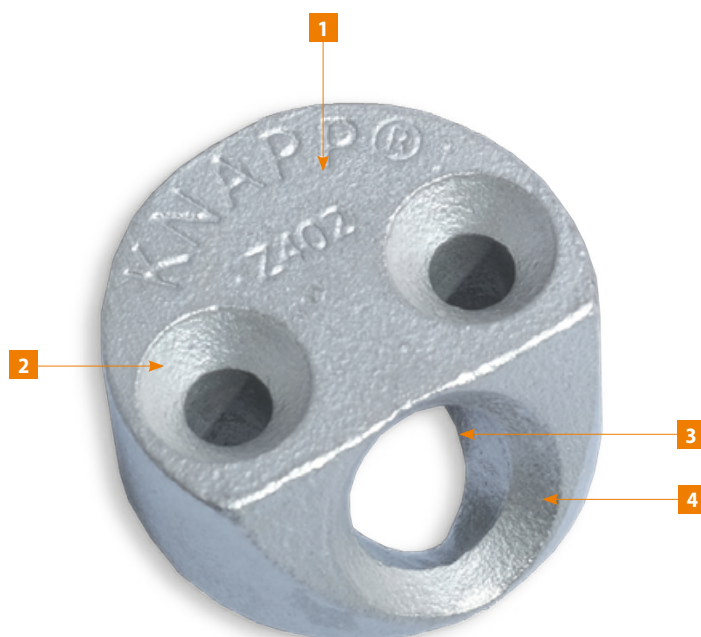

- 1 Cylinder connector for screwing into wooden parts (cast inox)
- 2 Cast steel screw connector for drilling into wooden components
- 3 Suitable for Ø8 to Ø12 mm countersunk screws
- 4 Optimum load distribution of the tensile force over the base and cylinder surface
- 5 Countersunk screw hole Ø5 to Ø6 mm for positioning and/or additional fixing

T-JOINT can be used alone or in combination with RICON® Connectors, RICON® S, WALCO® V and MEGANT®.



Installation



With T-JOINT D35 W30 fastened hardwood tension ties for BSH tension joints.



Carport without brace.

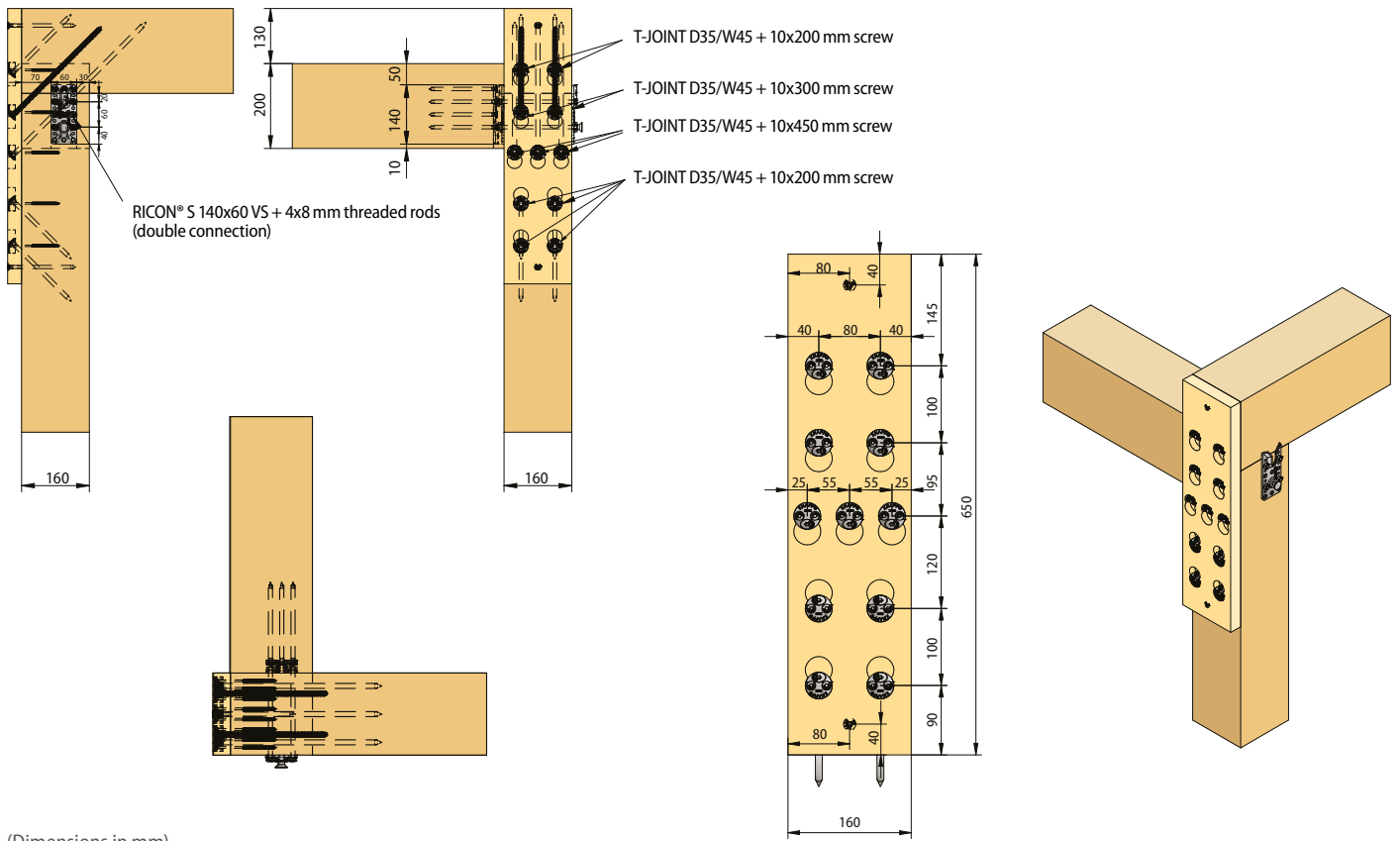

(Dimensions in mm)

Connection details

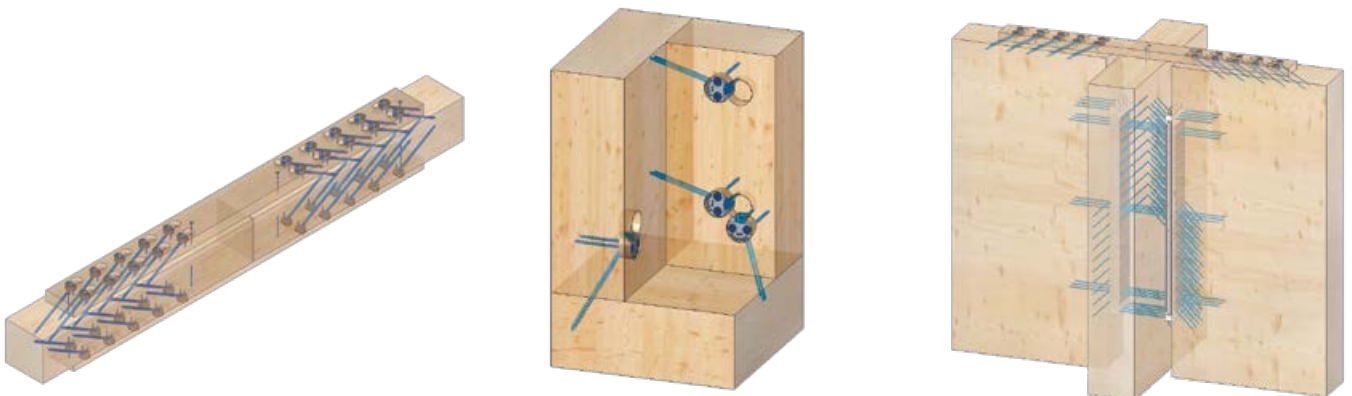

T-JOINT D35 W30 fastened hardwood tension ties for BSH tension joints.

Corner tensile connection with T-JOINT D35 W30.

MEGANT® main secondary beam connection with T-JOINT D35 W30 screwed-on hardwood tension ties.

T-JOINT

T-JOINT D35 W45 installation examples and connection details

Tie plate with T-JOINT D35 W45 and T-JOINT D20 W45

(Dimensions in mm)

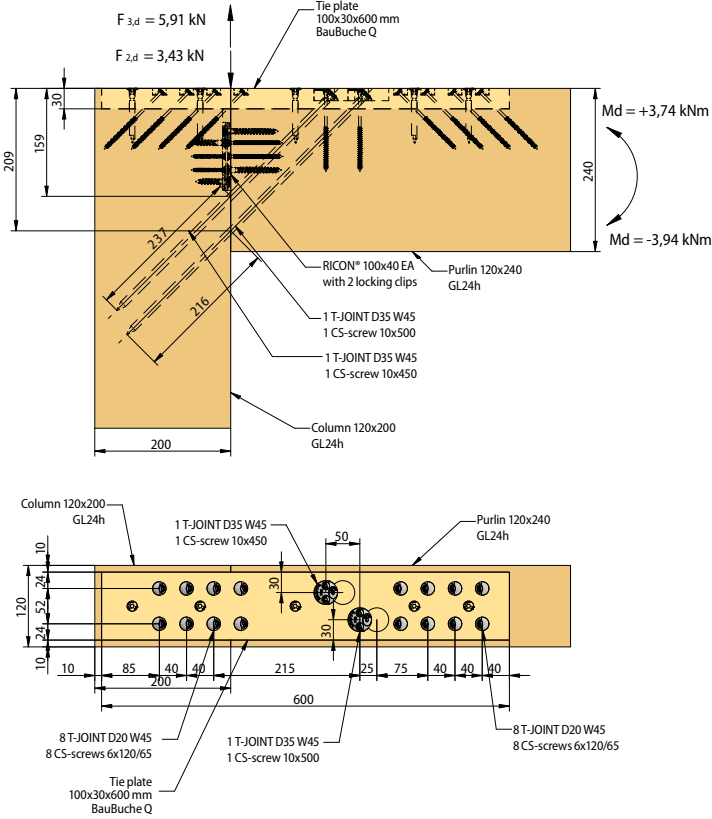

Column connection

Purlin connection

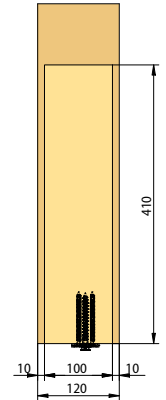
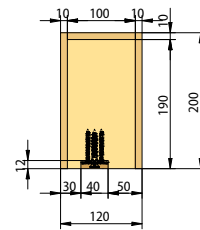
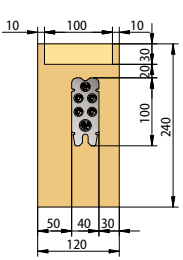
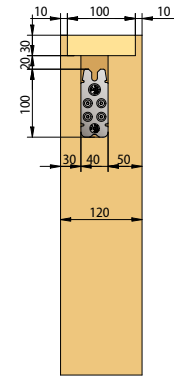

T-JOINT D35 W45 installation examples and connection details

Rigid connection with T-Joint and tie plate

(Dimensions in mm)

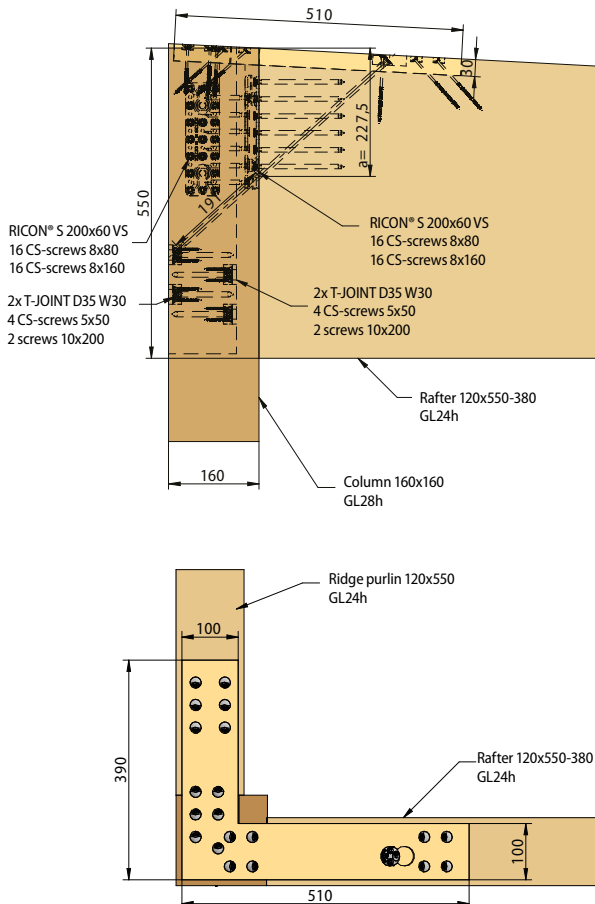

Rigid column-beam connection

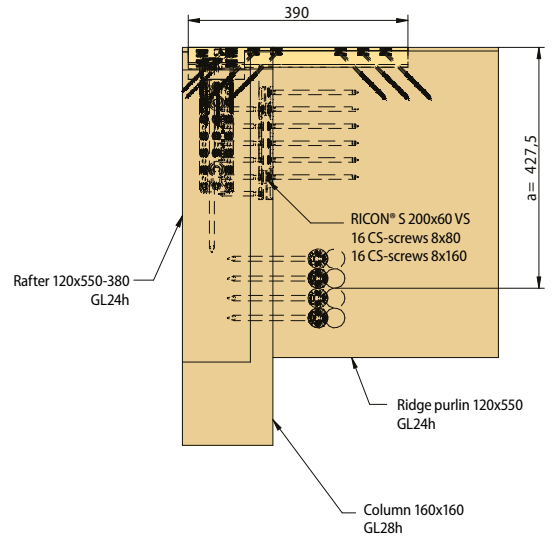

T-JOINT NOTICE

Installation examples



Inclined rafter connections attached to the top of the dome with T-JOINT.



Photo 1 and 2: Volkshöhe Tierpark Hellbrunn © Greinwald



Rigid frame corner with T-JOINT and tension tie made of laminated veneer lumber for terrace roof with the view on columns, purlins and rafters.



Photo 3, 4 and 5: © Hausmeisterservice Schwarzenberg



T-JOINT strengthening on post connections

Photo 6: © Tischlerei Mathias Komm



Jonctions de faitage, chevrons-poutres principales, rigides à la flexion avec T-Joint D40/W30.

Photo 9, 10 and 11: © KNAPP GmbH

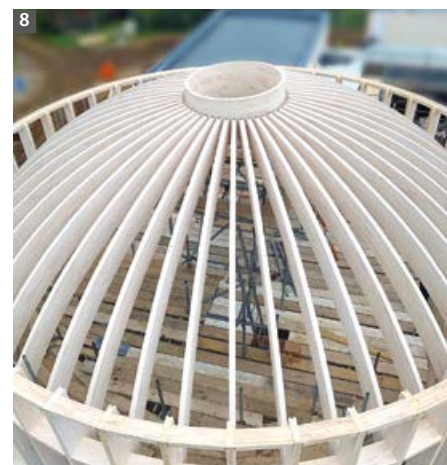

Photo 7 and 8: © Parcgrade BV White Eagle Lodge



Bending-resistant main beam-rafter connections with T-Joint D40/W30.

Installation



Manual processing with KNAPP® drilling templates.



T-JOINT D20 Drill hole approx. 3 mm deep



Pre-drill at an angle using the KNAPP® drilling template.



Screw on T-JOINT D20.



T-JOINT D30 or D35 prepositioned with 2 CS-screws Ø 5 mm¹.



Screw on T-JOINT.



T-JOINT screwed in place.

T-JOINT holes dim.

T-JOINT	Ø	Length	Depth
20	20mm		9,5mm
30	30mm	57mm	18mm
35	35mm	65mm	18mm
35 (45°)	35mm	50mm	18mm
40	40mm	—	3mm
40	40mm	75mm	18mm

¹ Pre-drilling of the fixing screws only for hardwood.

The T-JOINT makes it possible to produce inclined screw connections with exactly defined and repeatable screw angles in a statically calculable way.

The connection is very easy to handle, increases the degree of prefabrication and reduces assembly times as considerably fewer screws are required.

T-JOINT D20



T-JOINT D20/W45 - Galvanised cast steel

Art.-No. Z606

KNAPP® T-JOINT Ø 20 mm, 45° screw angle

Recommended screws:

KNAPP® CS-screws 6x100 mm (Art.-No. Z494) or
KNAPP® CS-screws 6x120 mm (Art.-No. Z495)

T-JOINT D30



T-JOINT D30/W30 - Galvanised cast steel

Art.-No. Z617

KNAPP® T-JOINT Ø 30 mm, angle de screw 30°

Recommended screws:

KNAPP® CS-screws 5x50 mm with reinforced shaft (Art.-No. Z533) or
KNAPP® CS-screws 5x80 mm with reinforced shaft (Art.-No. Z534)
Fixing: 2 screws are required for pre-assembling the T-JOINT D30.

KNAPP® CS-screws 8x160 mm with reinforced shaft (Art.-No. Z581) or
KNAPP® CS-screws 8x240 mm with reinforced shaft (Art.-No. Z672) or
KNAPP® CS-screws 10x200 mm with reinforced shaft (Art.-No. Z583)

T-JOINT D35



T-JOINT D35/30 and D35/45- inox

Art.-No. Z402

KNAPP® T-JOINT Ø 35 mm, 30° screw angle

Art.-No. Z403

KNAPP® T-JOINT Ø 35 mm, 45° screw angle

Application: for steep approach angles for diagonal screw connections.

Recommended screws:

KNAPP® CS-screws 5x50 mm with reinforced shaft (Art.-No. Z533) or
KNAPP® CS-screws 5x80 mm with reinforced shaft (Art.-No. Z534)
Fixing: 2 screws are required for pre-assembling the T-JOINT D35.

KNAPP® CS-screws 8x160 mm with reinforced shaft (Art.-No. Z581) or
KNAPP® CS-screws 8x240 mm with reinforced shaft (Art.-No. Z672) or
KNAPP® CS-screws 10x200 mm with reinforced shaft (Art.-No. Z583)

Works with screws up to Ø 12 mm.

Accessories

Art.-No. K256

Drilling template D20, 45° screw angle

Art.-No. K258 K266 K267

Drilling template D30, 30° (K258) ; D35, 30° (K266) ; D35, 45° (K267)

Art.-No. K563

Adjustable drilling template (for UNO 30, DUO 30, DUO 35 and T-JOINT)

Art.-No. Z075/20

HM drill bit 20 mm (for T-JOINT D20)

HM drill bit 30 mm (Art.-No. Z070); 35 mm (Art.-No. Z071) with depth stop (for T-JOINT)

T-JOINT D40



T-JOINT D40/W30

Art.-No. Z404	KNAPP® T-JOINT Ø40mm, 30° screw angle Fixing: for tension and bending joints of two timber components by means of diagonal screw connection from both sides.
	Recommended screws: KNAPP® CS-screws 8x120 mm with reinforced shaft (Art.-No. Z670), KNAPP® CS-screws 8x160 mm with reinforced shaft (Art.-No. Z673), KNAPP® CS-screws 8x200 mm with reinforced shaft (Art.-No. Z671) or KNAPP® CS-screws 8x240 mm with reinforced shaft (Art.-No. Z672) Application: 2 pieces are required for pre-assembly of the T-JOINT D40.
	KNAPP® CS-screws 10x200 mm with reinforced shaft (Art.-No. Z583) or KNAPP® CS-screws 10x300 mm with reinforced shaft (Art.-No. Z651)

Application examples and connection details of T-JOINT D40 W30

Assembly of 2 CLT wall elements

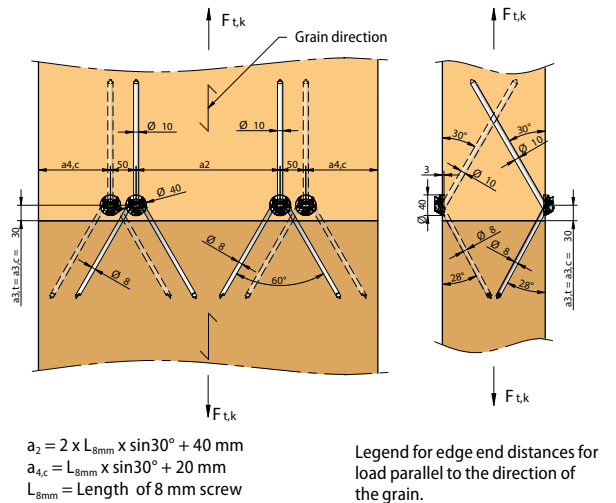
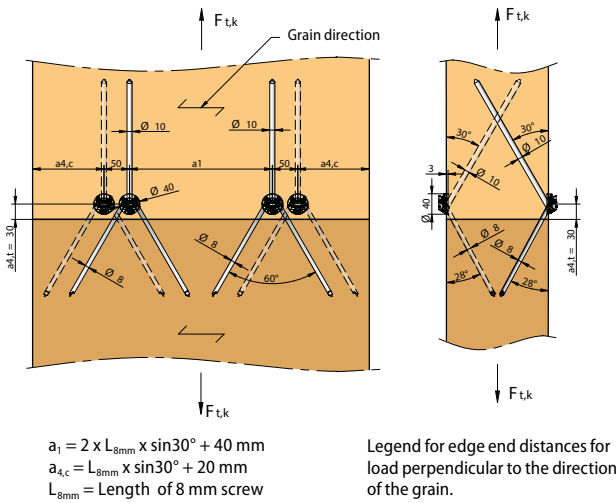

Main beam - secondary beam connection

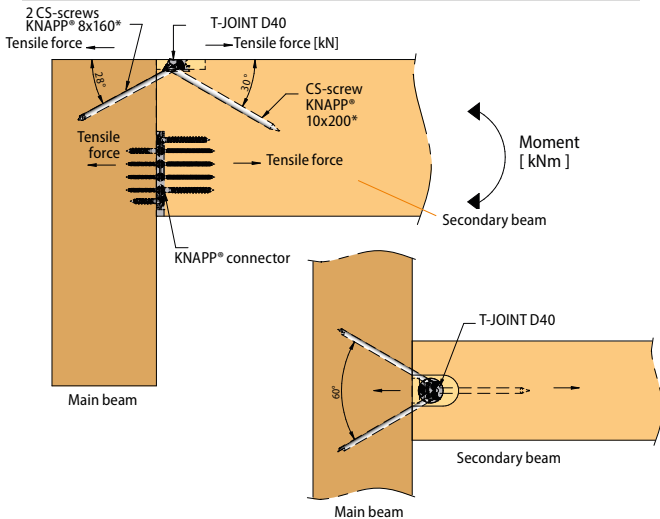

Post and beam connection

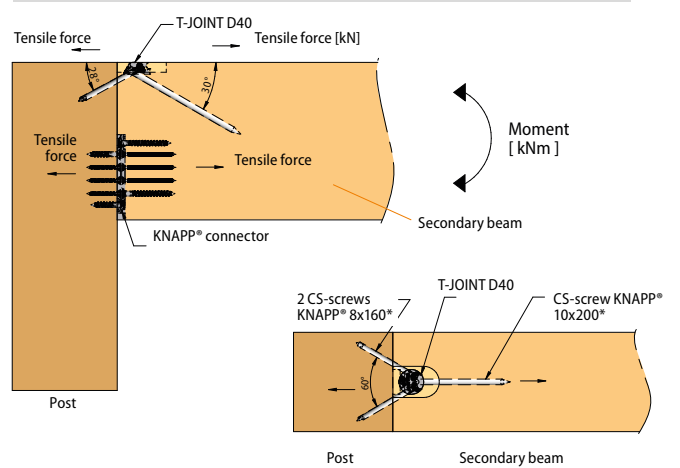

Tensile connection of CLT floor to wall

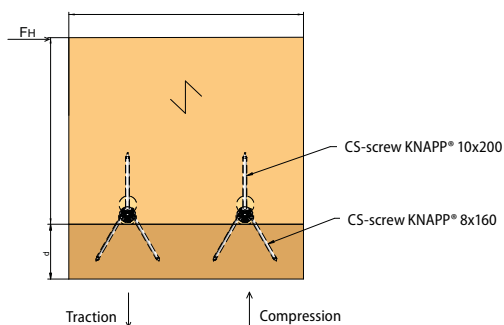

Bending joint of CLT ceiling elements

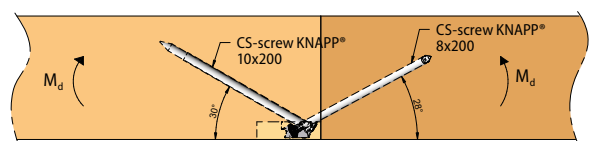

Meet our partner

Applications: for fixing indoor and outdoor posts and railings,
for staircases, verandas, terraces and balconies



VIDEO

ZIPBOLT™ UT POST ANCHOR

Post connector

Art.-No. Z381

NEW

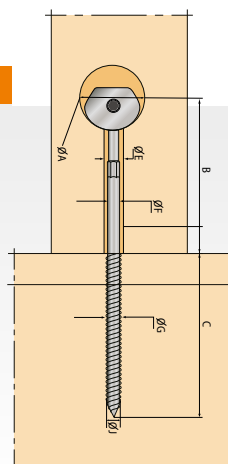

G = 13,5 | J = +/- 10 mm

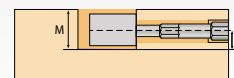

M	Height	X	Ø A	B	C	Ø F	E
> 28 mm	260 mm	14 mm	35 mm	125 mm	143 mm	11 mm	13 mm

- Applications:** Fixing staircase posts.
- Advantages:** Fast and easily installed by using a T40 Torx Bit and a cordless drill.
- Suitable materials:** All kind of solid wood materials.
- Installation:** Pre-drill holes using plunge router or CNC.
- Mounting:** Insert connector parts into holes and assemble.

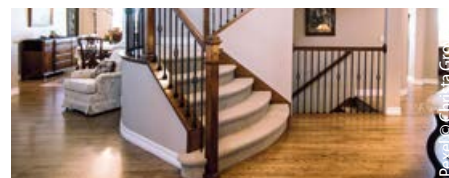

ZIPBOLT™ XT POST ANCHOR

External post

connector

Art.-No. Z379



NEW

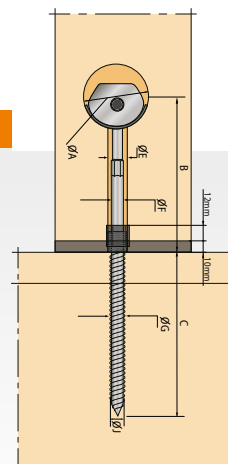

G = 13,5 | J = +/- 10 mm

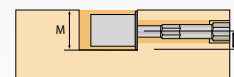
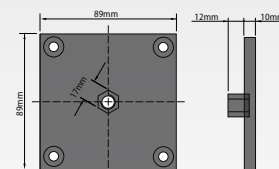

M	Height	X	Ø A	B	C	Ø F	E
37 mm	260 mm	18 mm	38 mm	124 mm	130 mm	11mm	16 mm

- Applications:** Connection for external posts on terraces and verandas.
- Advantages:** Fast and easily installed by using a 6mm hex bit and a cordless drill.
- Suitable materials:** All kind of solid wood materials.
- Installation:** Pre-drill holes using plunge router or CNC.
- Mounting:** Insert connector parts into holes and assemble.



Find these systems and many other solutions in our catalogue of assemblies for fittings,
interior and exterior joinery, staircases and landscaping.



CATALOG

Timber peg connector made of solid hardwood

**Timber construction nail,
connecting up to 11,4 kN***

- | Timber width from 80 mm
- | Drilling in the factory or on site
- | Sustainable and durable
- | Sophisticated natural look
- | Force-locking and self-tightening connection
- | Two to three steps pre-lockable and self-centring
- | Metal-free connection

MATEO



Available in 1 size and 2 types of wood.

Find all the resistance data on our website.

* $F_{2,RK}$ characteristic value with MATEO ash timber peg on CLT.



© Holz Lengauer

Installation example: CLT walls installation.

MATEO

- Applications: visible connection in ecological house construction
- Connections: wood-wood, solid wood, wood-based materials e.g. CLT
- Areas of application: traditional house building, renovation

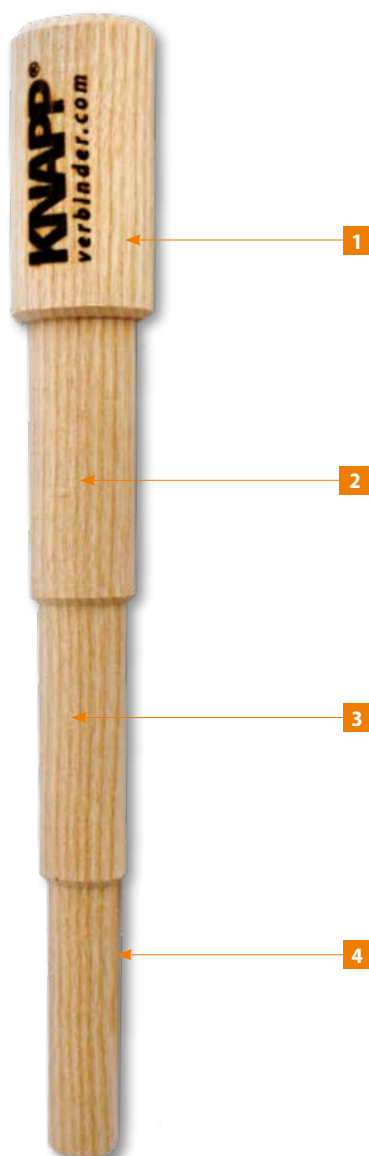

- 1 Ø 40 round nail head
- 2 Stepped shaft (1st step Ø 30)
- 3 Woodturned (2nd step Ø 25)
- 4 Solid hardwood (3rd step Ø 20)

The MATEO wooden peg is available made of ash (Art.-No. K304) and beech (Art.-No. K303).

Ash: tough and ductile (deformable) load-bearing up to 0.8 tonnes (transverse to grain direction F_2).

Beech: even higher load-bearing capacity up to 1 ton (see load table on the next pages)

Dimensionally stable at 7-8 % moisture content.

After installation, the peg expands and holds the components firmly together. Glued with waterproof glue, higher pull-out values can be achieved and the connection can be secured additionally.



MATEO

Options of application

(Dimensions in mm)

4 steps

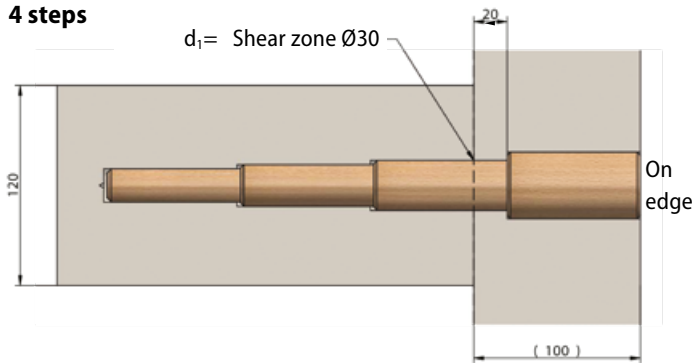

3 steps

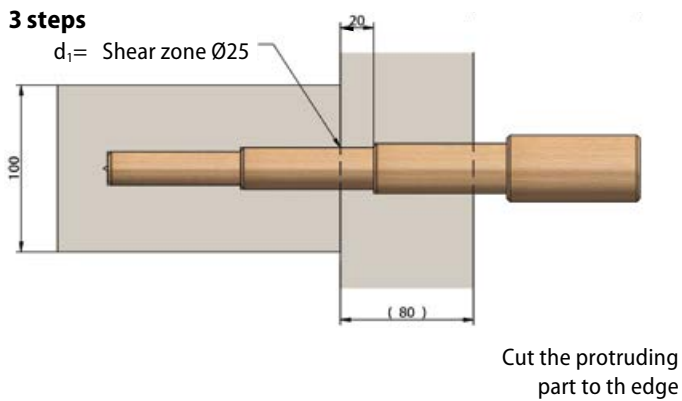

Application examples

End connections

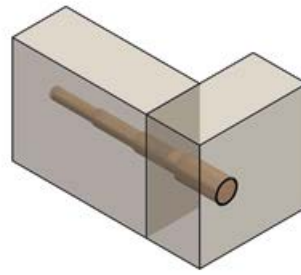

Corner connection

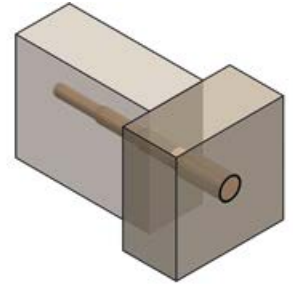

Double tie joints



Butt joints

Measurements

Art.-No. K303 and K304

Art.-No. Z093

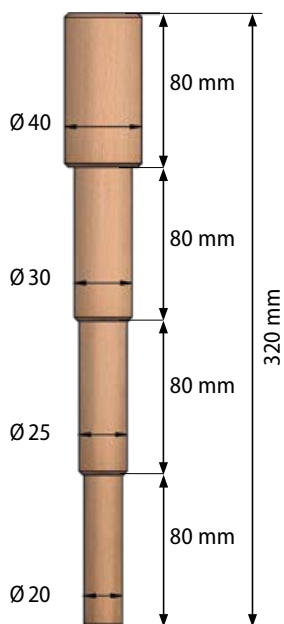

HS stepped drill



Minimum distances

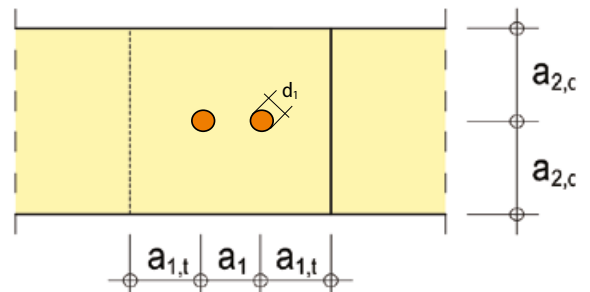

$$\text{Intervals : } a_{1,t} = a_1 = a_{2,c} = 2 \times d_1$$

d_1 = Mateo shear zone diameter..

For CNC systems, we can match the drills according to your needs.

MATEO

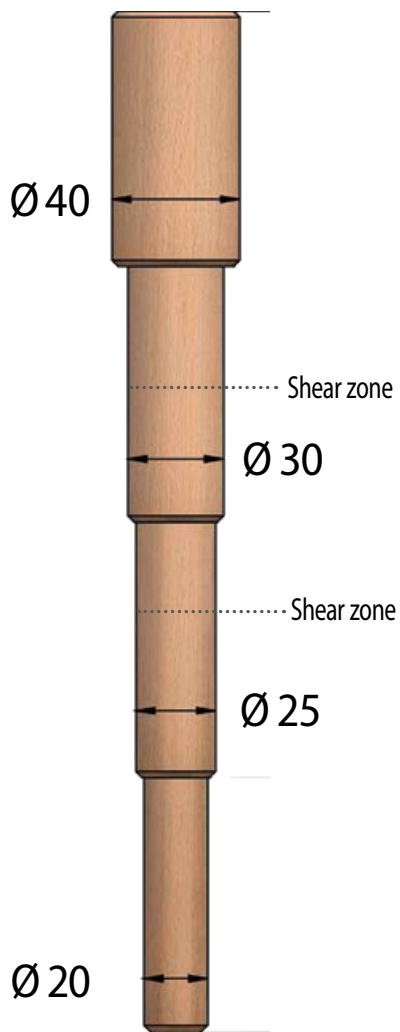
Tested shear zones at $\varnothing 25$ and 30 mm

Loadbearing capacities on shear force of side wood/end grain

Timber grade	Wood species	$\varnothing d_1$ Shear zone [mm]	$F_{2,Rk}$ [kN]	Min. wood thickness [mm]
C24	Ash Beech	30	9,8	80
			10,5	100
GL24h	Ash Beech	30	10,3	80
			11,0	100
BSPH	Ash Beech	30	11,4	70
			12,2	80

Timber grade	Wood species	$\varnothing d_1$ Shear zone [mm]	$F_{2,Rk}$ [kN]	Min. wood thickness [mm]
C24	Ash Beech	25	7,0	70
			7,6	70
GL24h	Ash Beech	25	7,4	70
			7,9	70
BSPH	Ash Beech	25	8,2	60
			8,8	60

The $F_{45,Rk}$ depends on the width of the secondary beam, for smaller width its value will be smaller.

Source of the calculation formulas: Blaß, H.J.; Ernst, H.; Werner, H.
"Connections with wooden pins - Investigations on load-bearing capacity" p. 630-631.

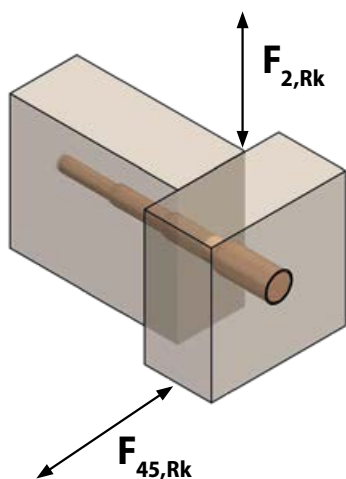

Installation



Manual drilling using a stepped drill bit or industrial drilling on a CNC machine



Insert the peg up to the nail head



Drive in until it stops



Cut and sand the excess part

Outdoor connectors

Invisible fastening systems for terraces, cladding and wall cladding indoors and out



OUTDOOR



Pergola sunshade with UNO 30



Garden furniture built with KNAPP® dowels



Terrace built with QUATRO 65

Overview of Knapp solutions for outdoor use :

The following items are available in our catalogue for interior and exterior fittings, window construction and wood structures



CATALOG



QUATRO 65
Made of highly resistant composite plastic
Quatro 65/25
Art.-No.K081
Quatro 65/30
Art.-No.K080



QUATRO Page 78



Z-DECK
Terrace connector made of inox
Art.-No. K082



Z-DECK Page 79



ZIPBOLT™
Exterior Slipfix
For outdoor handrails
Art.-No.Z374



SLIPFIX Page 37



UNO 30 (Garniture)
Inox hook system

Art.-No.K120
UNO 30 Set
Art.-No.K120/B
UNO 30 (connector only)



UNO 30

Page 22



DUO 30 inox A5
Inox A5 hook connector

Art.-No.K350
Art.-No.K350/P
Mini Pack
Art.-No.K121
Goupille de verrouillage A2 (option)



DUO30 INOX

Page 21

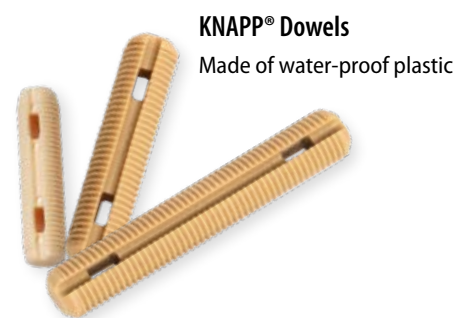

KNAPP® Dowels
Made of water-proof plastic

Art.-No.K066
6x28 mm
Art.-No.K067
8x36 mm
Art.-No.K169
8x50 mm



KNAPP DOWEL

Page 24

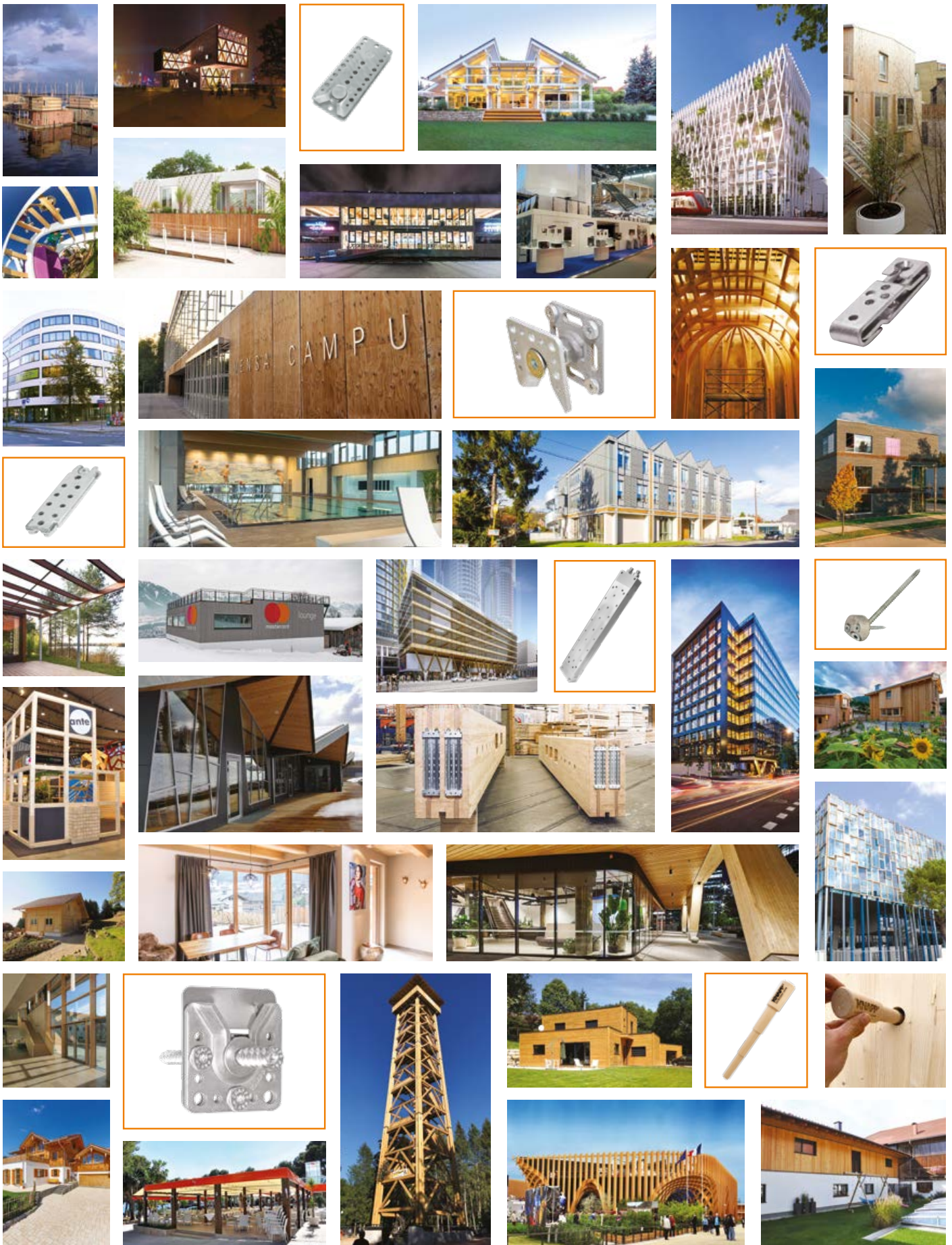
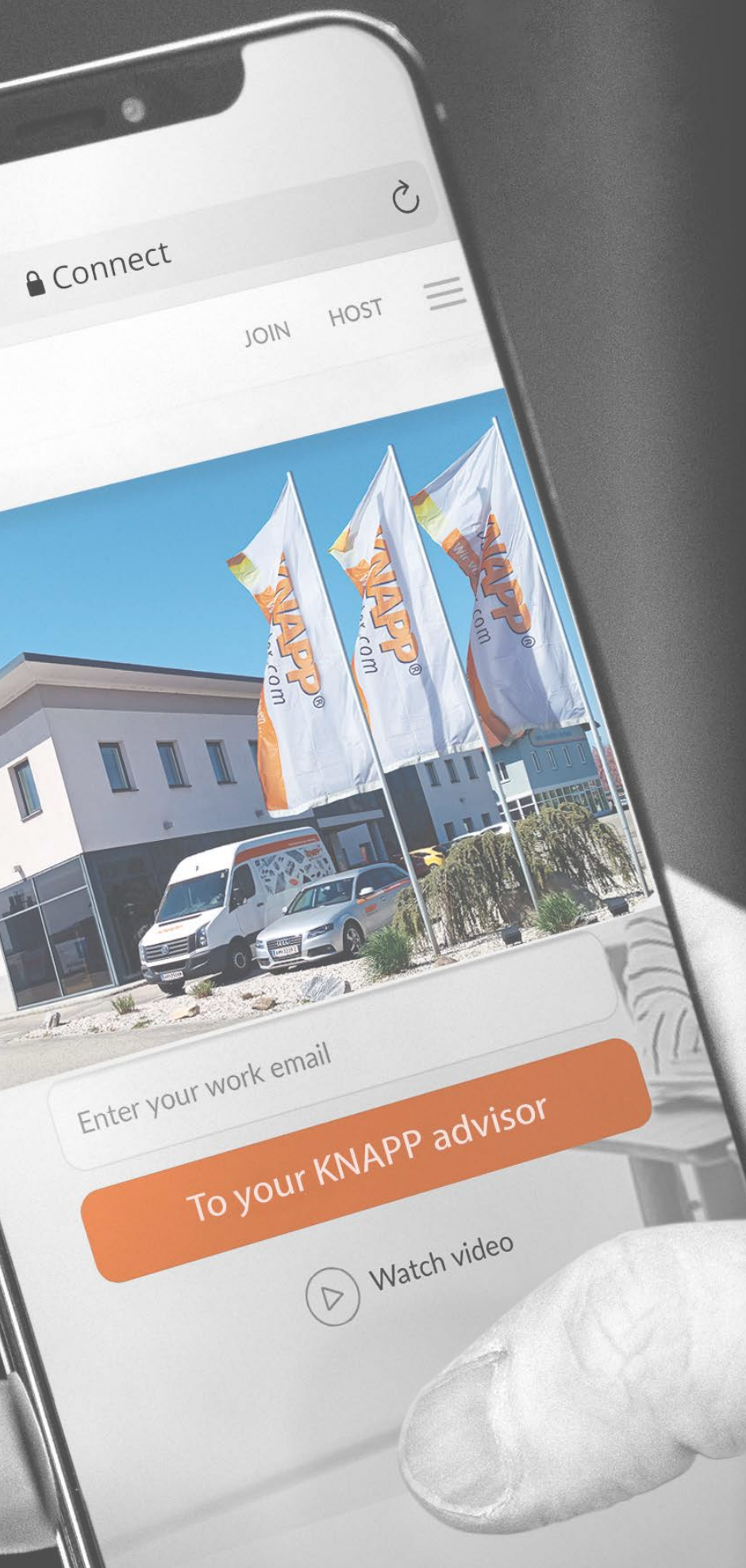

Photo credits, from top left: HOKO-Fertighaus GmbH | Im Jaich | Hamburg Haus, Shanghai | Spengler Wiescholek | Huf Haus | Palazzo Meridia | AntoineDuhamel Photography architecturestudio | Becker & Sohn, SUSD Ltd. | Montafoner Kristbergbahn GmbH | Solar Decathlon Team Ikarus | Thomas Huber, HS Rosenheim | Andreas Aufschneider, Red Bull Content Pool | Stand SAMSUNG | Bruckschwaiger | Sunyard, Nickl & Partner Architekten | TUM Mensa Garching | Chapelle de la Pureté, Sébastien Daniel | Piscine Ried | Olivier Anbergen | Lothar Hennig | Solarlux | Jens Kirchner | Stand ante-holz GmbH | artofisight | P. Lienbacher Holzbauwerk GmbH | House Sydney Barangaroo | Lendlease | Lendlease, Bates Smart, Tom Roe | Atelier D-Form | Lendlease, Bates Smart, Tom Roe | Rensteph Thompson | Holzwerkstatt EBI | Alpegg | defrancesco photography | K25 Brisbane | Lendlease | CMA Entreprises | Ecole Feldkirchen | Franck | Maison Eau & Soleil | Holzbau Lengauer | Holzbau Prutscher | Holzbau Amann | Pergola restaurant, La Carcoma | Goetherturm | Holzbau Amann GmbH | Pavillon Expo Milan | Habitation Holzbau Lengauer



Solutions innovantes
Made in Austria
Family Business
depuis 1983
Connecteur d'idées,
pour la construction bois



▶▶▶ On-site consultation

For international requests, we are also available via video call or through our business partners. All contact details are available on our website:

www.knapp-connectors.com/en/contact/



▶▶▶ Contact

 +43 (0) 7474 / 799 10

 +43 (0) 7474 / 799 10 28

info@knapp-connectors.com



▶▶▶ Download

All brochures, assembly instructions, CAD drawings and many details can be downloaded after registration on our website.

knapp-connectors.com/en/downloads

HOW TO ORDER? IT'S AS SIMPLE AS THAT:

Scan the QR code with your mobile phone or go to our website www.knapp-connectors.com/en/ log in with your username and password or create an account and get connected!



▶▶▶ online-store

Not available in Switzerland and in the Americas



WEBSITE

Concealed | Self-tightening | Demountable



30.05.2024 | KNAPP® Connecting systems for timber construction - Brochure | © The KNAPP® logo is a registered trademark of the trademark owner Knapp GmbH, A-3324 Eurats

The technical content of this brochure is valid until a new version is published (always updated and downloadable from the internet). This document is the exclusive property of Knapp GmbH. Any copying, reproduction, publication and also the use of extracts are subject to the prior written consent of Knapp GmbH. Errors, misprints or changes excepted and technical reservations. The verification and adaptation of drawings, calculations or any technical details, in particular static data, remain the responsibility of the customer. Additional calculations and drawings published by Knapp GmbH are suggestions for orientation and are not guarantees, the customers are always obliged to check these data and to adapt them to their specific case. The pictures in this document are available in computer format on request from our marketing department. All rights reserved. Copyright © 2024 by Knapp GmbH.



Knapp GmbH | Wassergasse 31 | A-3324 Euratsfeld
Tél. : +43 (0)7474 / 799 10 | Fax: +43 (0)7474 / 799 10 99

E-Mail : info@knapp-connectors.com | www.knapp-connectors.com/en



KNAPP®
connectors.com