

RICON® 120/40



ETA-10/0189

Pfosten-Riegelverbindung
mit Bauzulassung (DE+EU)
post and latch connection

with construction supervisory approval (DE+EU)

<p>RICON® 120/40</p>	<p>RICON® SK Scr 8x80</p>	<p>RICON® ISK M 8x25, M8x20</p>
	<p>RICON® SK Scr 8x50</p>	<p>Verbundmutter/ connecting nut M8x36,48,53, 58, 68, 78</p>
	<p>RICON® SK Scr 5x80</p>	
	<p>RICON® SK Scr 5x50</p>	<p>RICON® Einschraub- mutter / insert M8x18</p>
	<p>RICON® Sperrbügel / stirrup</p>	

Einzel und Doppelanschluss
single and double connection

Pfosten-Riegelverbindung
latch and post connection

Riegel Fräsbild /
Milled edge latch

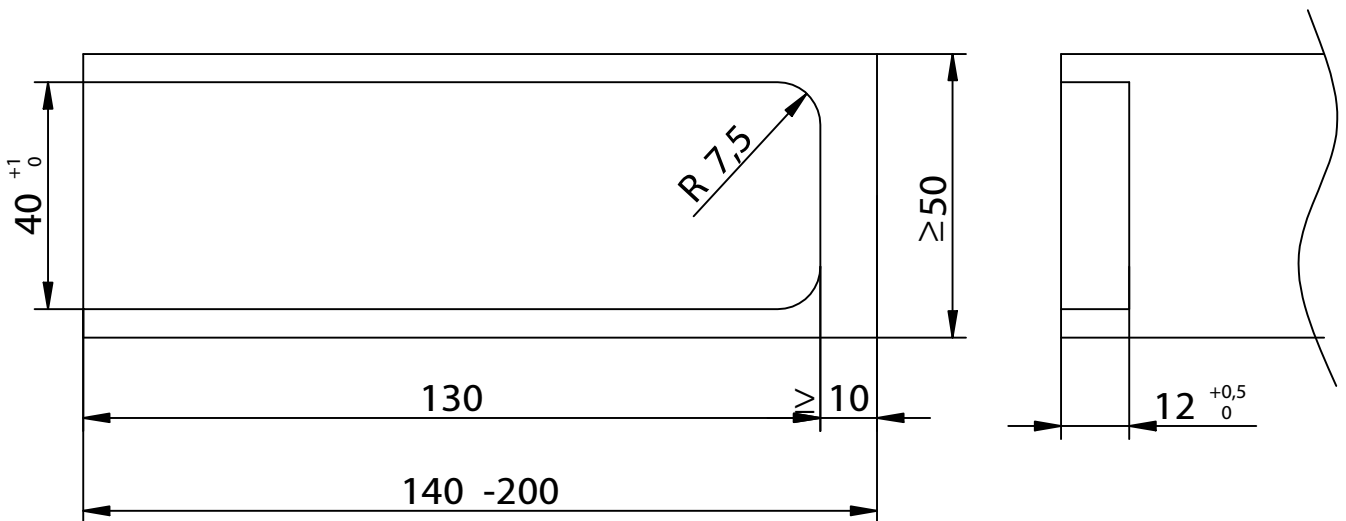

Diese Zeichnung ist Eigentum der Knapp GmbH.

© Knapp GmbH. Alle Maße in mm - Irrtümer, Druckfehler und Änderungen vorbehalten. VERSION 06.11.2013

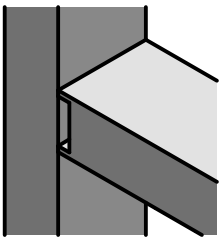

Montageanleitung/Construction Manual

RICON® 120/40 EA

Art. Nr. K363

**Einzelanschluss
single connection**

**Pfosten-Riegelverbindung
latch and post connection**

Bohrbild im Riegel /
drilling template for latch

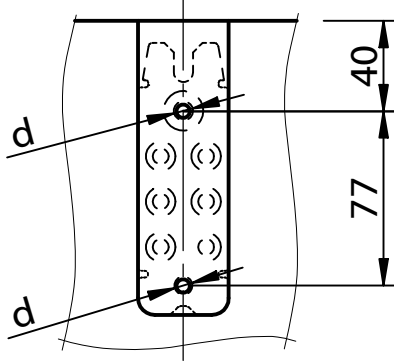

d...Ø 5mm, 30mm tief vorbohren
d...Ø 5mm, 30mm deep predrilling

Bohrbild im Pfosten /
drilling template for post

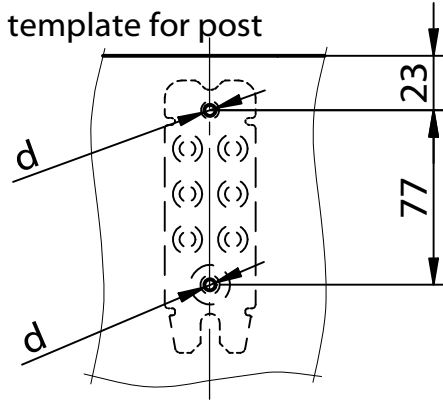

d...Ø 5mm, 30mm tief vorbohren
d...Ø 5mm, 30mm deep predrilling

Schraubenbild im Riegel /
screw template for latch

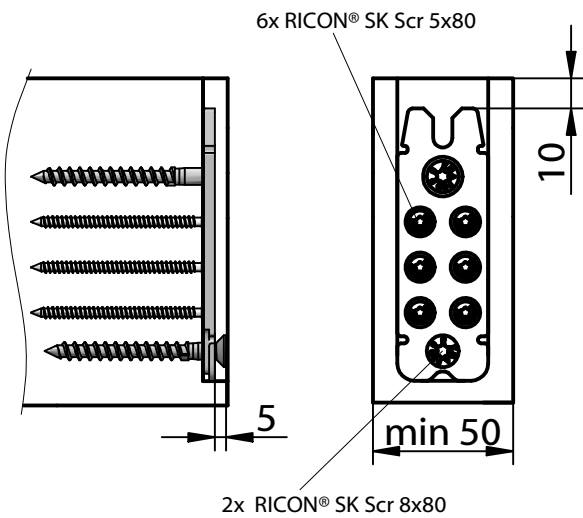

Schraubenbild im Pfosten /
screw template for post

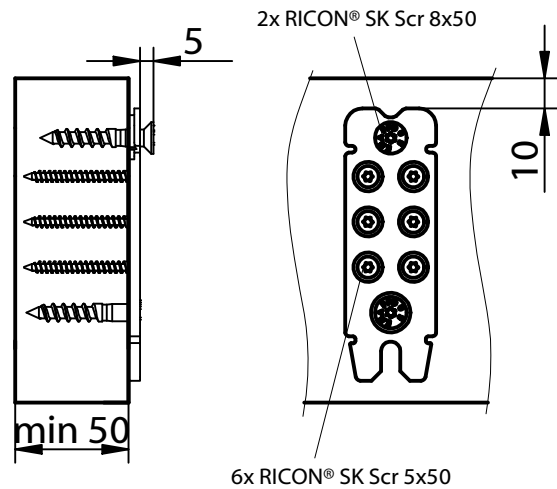

Einstellen der Schraube /
screw position adjustment

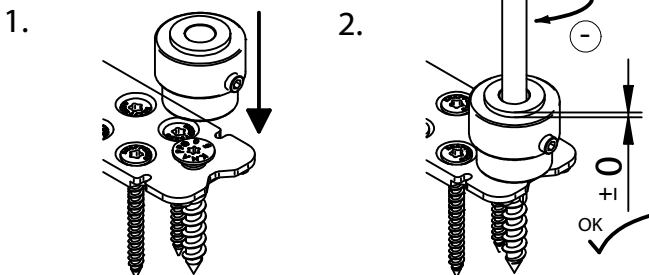

Sperrbügel einlegen /
assemble stirrup

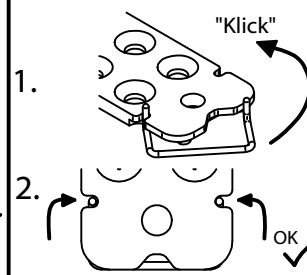

Sperrbügel lösen /
remove stirrup

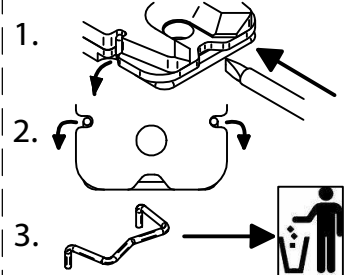

Diese Zeichnung ist Eigentum der Knapp GmbH.

© Knapp GmbH. Alle Maße in mm - Irrtümer, Druckfehler und Änderungen vorbehalten. VERSION 06.11.2013

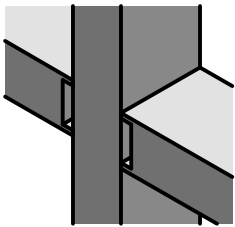

RICON® 120/40 DA

Art. Nr. K163/48;
K163/58; K163/78

Doppelanschluss
double connection

Pfosten-Riegelverbindung
latch and post connection

Bohrbild im Riegel /
drilling template for latch

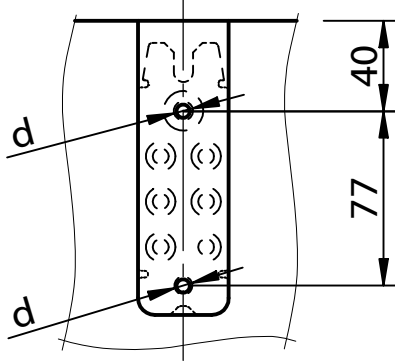

d...Ø 5mm, 30mm tief vorbohren
d...Ø 5mm, 30mm deep predrilling

Bohrbild im Pfosten /
drilling template for post

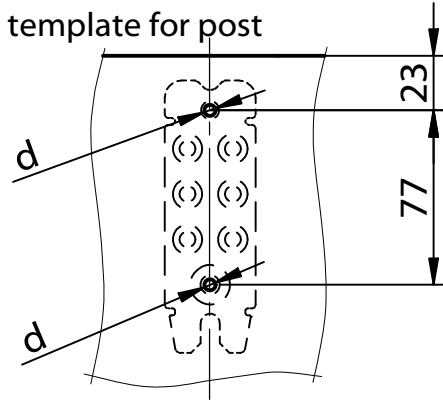

d...Ø 10mm, Durchgangsloch
d...Ø 10mm, throughhole

Schraubenbild im Riegel /
screw template for latch

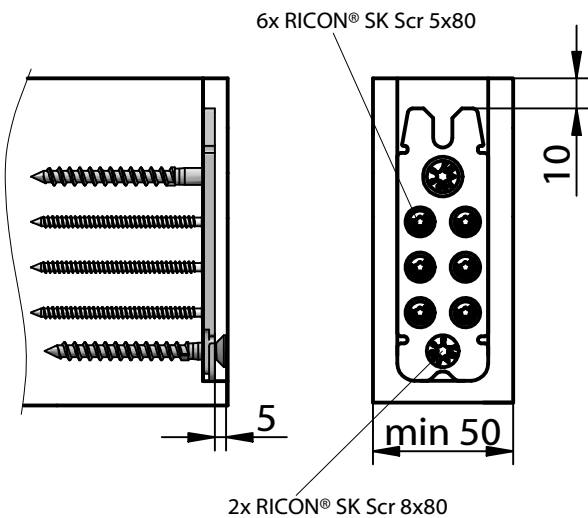

2x RICON® SK Scr 8x80

Schraubenbild im Pfosten /
screw template for post

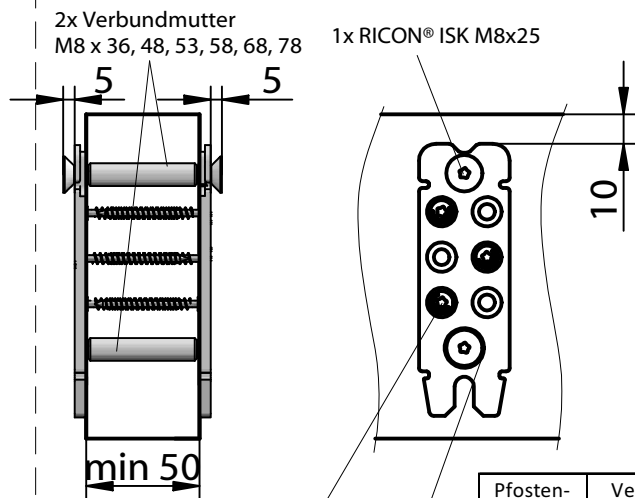

2x Verbundmutter
M8 x 36, 48, 53, 58, 68, 78

1x RICON® ISK M8x25

3x RICON® SK Scr 5x50
wechselseitig

1x RICON® ISK M8x25

Pfosten- stärke [mm]	Verbund- mutterlänge [mm]
50	48
56	53
60	58
80	78

Einstellen der Schraube /
screw position adjustment

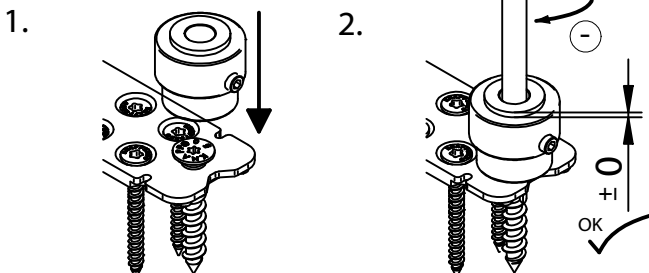

Sperrbügel einlegen /
assemble stirrup

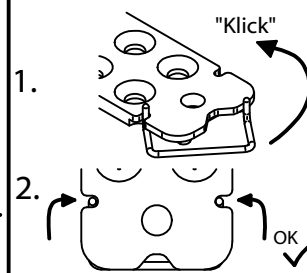

Sperrbügel lösen /
remove stirrup

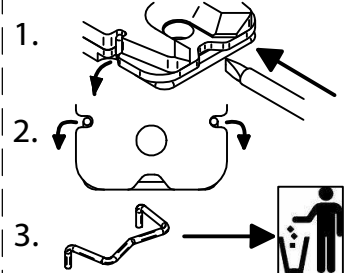

Diese Zeichnung ist Eigentum der Knapp GmbH.

© Knapp GmbH. Alle Maße in mm - Irrtümer, Druckfehler und Änderungen vorbehalten. VERSION 06.11.2013

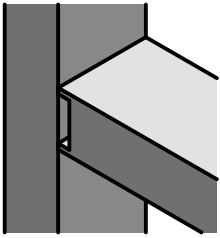

Montageanleitung/Construction Manual

RICON® 120/40 EAR

Art. Nr. K263

Einzelanschluss mit Einschraubmutter
single connection with insert screw

Pfosten-Riegelverbindung
post and latch connection

Bohrbild im Riegel /
 drilling template for latch

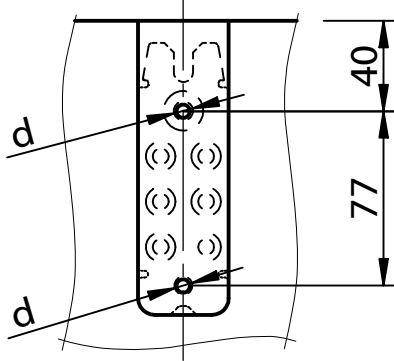

d...Ø 5mm, 30mm tief vorbohren
 d...Ø 5mm, 30mm deep predrilling

Bohrbild im Pfosten /
 drilling template for post

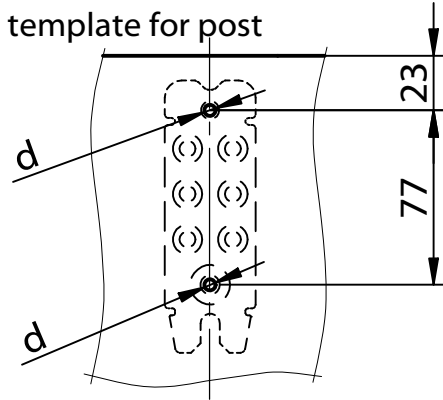

d...Ø 12 mm, 20 mm tief vorbohren
 d...Ø 12 mm, 20mm deep predrilling

Schraubenbild im Riegel /
 screw template for latch

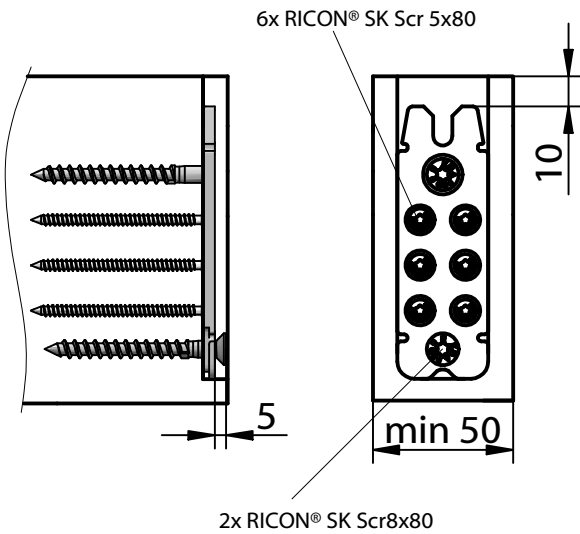

Schraubenbild im Pfosten /
 screw template for post

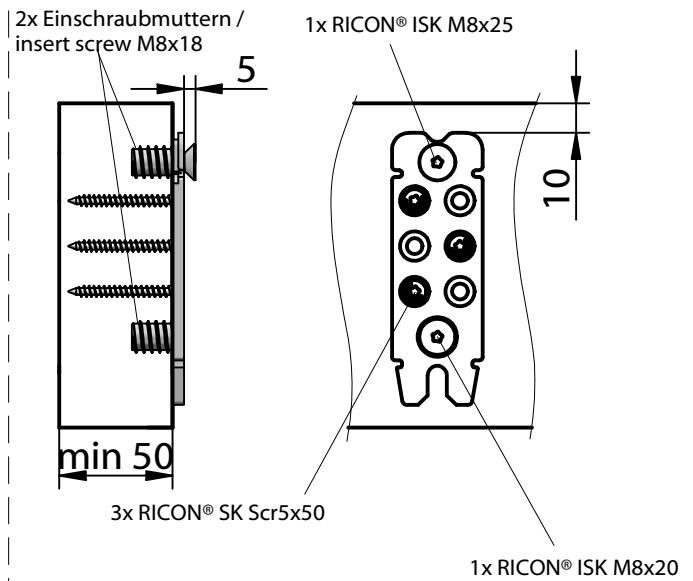

Einstellen der Schraube /
 screw position adjustment

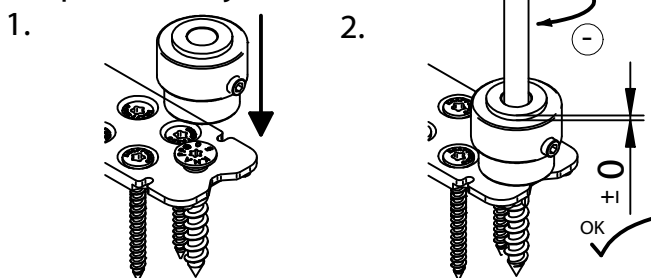

Sperrbügel einlegen /
 assemble stirrup

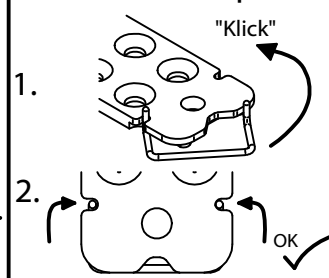

Sperrbügel lösen /
 remove stirrup

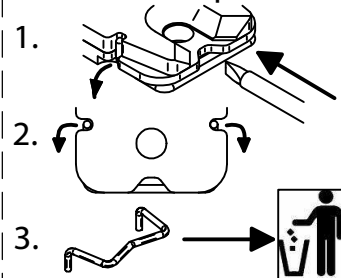

Diese Zeichnung ist Eigentum der Knapp GmbH.

© Knapp GmbH. Alle Maße in mm - Irrtümer, Druckfehler und Änderungen vorbehalten. VERSION 06.11.2013



ETA-10/0189

Haupt- Nebenträgerverbindung
mit Bauzulassung (DE + EU)

main girder- joist connection -
with construction supervisory approval (DE + EU)

RICON® 120/40

RICON® SK Scr 8x80

RICON® SK Scr 8x50

RICON® SK Scr 5x80

RICON® SK Scr 5x50

RICON® Sperrbügel / stirrup

RICON® ISK M 8x25, M8x20

Verbundmutter/
connecting nut
M8x36,48,53, 58, 68, 78

RICON® Einschraub-
mutter / insert M8x18

Einzel- und Doppelanschluss
single and double connection

Haupt-Nebenträgerverbindung
main girder - joist connection

Hauptträger Fräsbild /Milled edge main girder

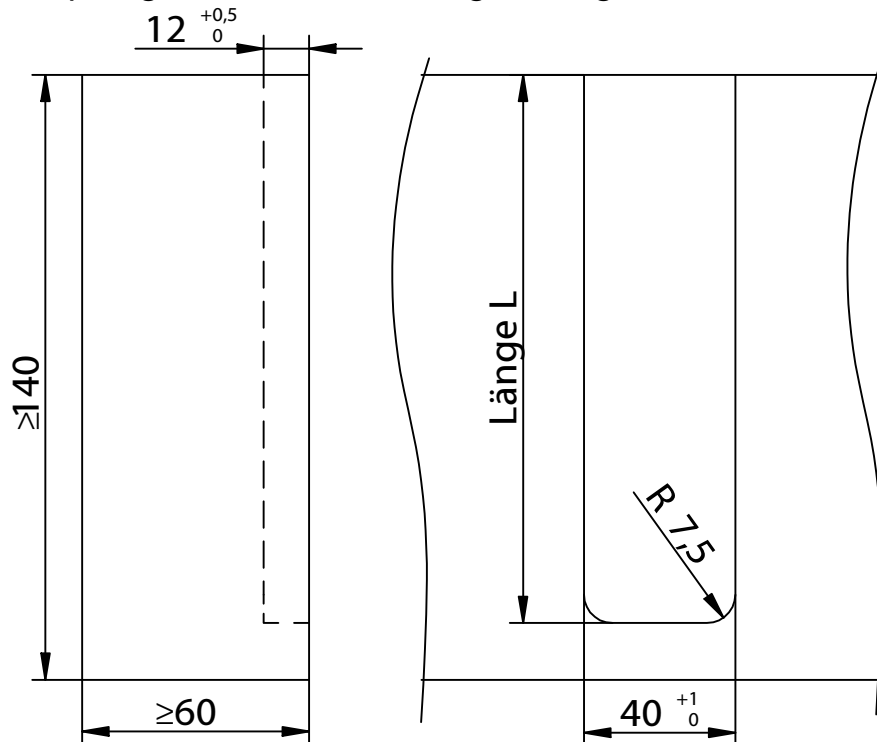

Ausfräslänge L aus dem Haupt-
träger in Abhängigkeit der Neben-
trägerhöhe HN /
Rebate length for main girder in
reference of the height HN of the
joist:

Höhe / Height HN [mm]	Länge/ Length L [mm]
140	130
160	140
180	160
200	170
220	180

Diese Zeichnung ist Eigentum der Knapp GmbH.

© Knapp GmbH. Alle Maße in mm - Irrtümer, Druckfehler und Änderungen vorbehalten. VERSION 06.11.2013

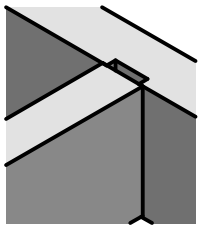

Montageanleitung/Construction Manual RICON® 120/40 EA

Art. Nr. K363 Einzelanschluss
single connection

Haupt-Nebenträger Verbindung
main girder - joist connection

Bohrbild im Hauptträger /
drilling template for main girder

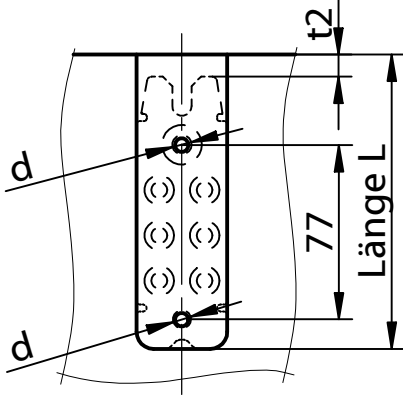

d...Ø 5mm, 30mm tief vorbohren
d...Ø 5mm, 30mm deep predrilling

Bohrbild im Nebenträger /
drilling template for joist

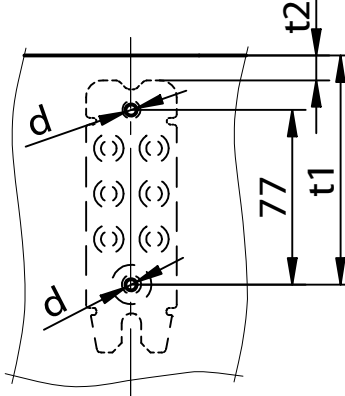

d...Ø 5mm, 30mm tief vorbohren
d...Ø 5mm, 30mm deep predrilling

Einbohrmaße t1 und Abstandsmaße t2 in
Abhängigkeit der Nebenträgerhöhe HN/
Bore measure t1 and distance t2 for joist in
reference to the height HN of the joist

Höhe / Height HN [mm]	Abstand/ Distance t1 [mm]	Abstand/ Distance t2 [mm]
140	100	10
160	110	20
180	130	40
200	140	50
220	150	60

Schraubenbild im Hauptträger /
screw template for main girder

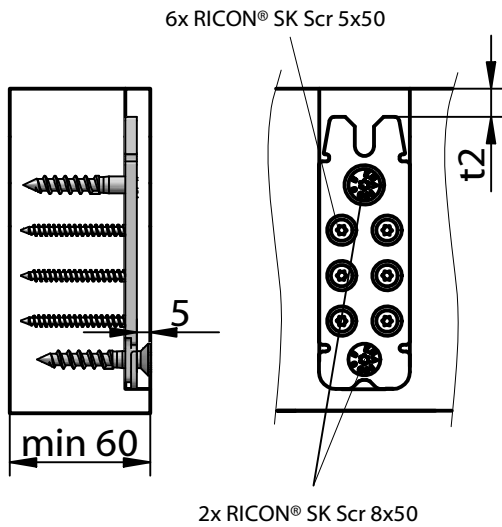

Schraubenbild im Nebenträger /
screw template for joist

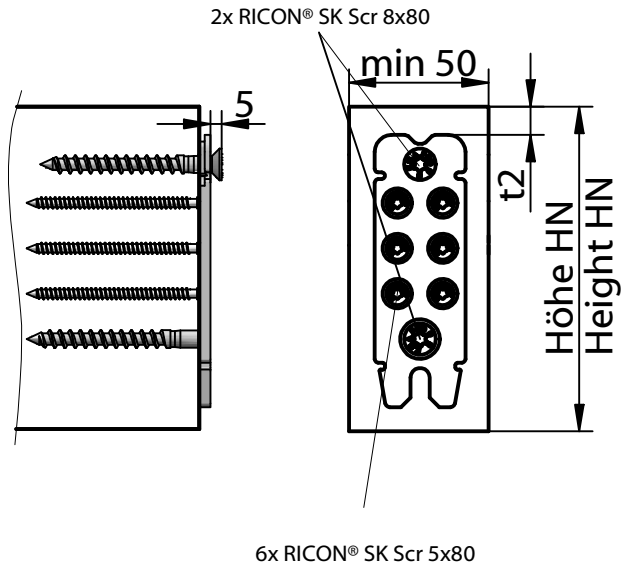

Einstellen der Schraube /
screw position adjustment

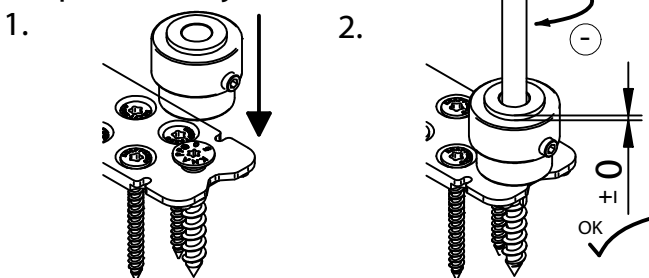

Sperrbügel einlegen /
assemble stirrup

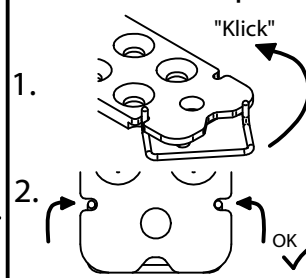

Sperrbügel lösen /
remove stirrup

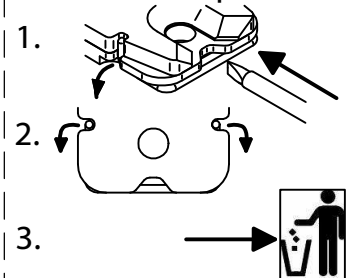

Diese Zeichnung ist Eigentum der Knapp GmbH.

© Knapp GmbH. Alle Maße in mm - Irrtümer, Druckfehler und Änderungen vorbehalten. VERSION 06.11.2013

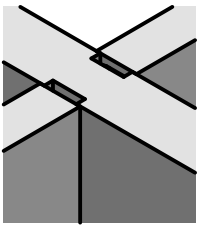

Montageanleitung/Construction Manual RICON® 120/40 DA

Art. Nr. K163/48;
K163/58; K163/78

Doppelanschluss
double connection

Haupt-Nebenträger Verbindung
main girder - joist connection

Bohrbild im Hauptträger /
drilling template for main girder

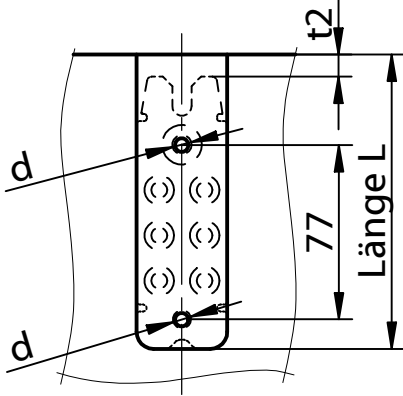

d...Ø 10mm, Durchgangsloch
d...Ø 10mm, throughhole

Bohrbild im Nebenträger /
drilling template for joist

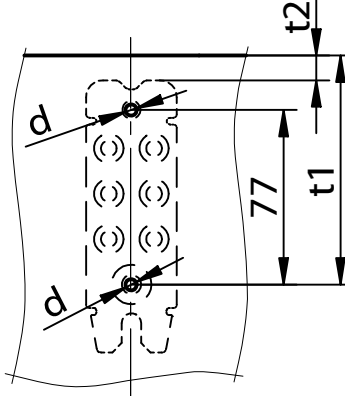

d...Ø 5mm, 30mm tief vorbohren
d...Ø 5mm, 30mm deep predrilling

Einbohrmaße t1 und Abstandsmaß t2 in
Abhängigkeit der Nebenträgerhöhe HN/
Bore measure t1 and distance t2 for joist in
reference to the height HN of the joist

Höhe / Height HN [mm]	Abstand/ Distance t1 [mm]	Abstand/ Distance t2 [mm]
140	100	10
160	110	20
180	130	40
200	140	50
220	150	60

Schraubenbild im Hauptträger /
screw template for main girder

2x Verbundmutter
M8 x 36, 48, 53, 58, 68, 78 1x RICON® ISK M8x25

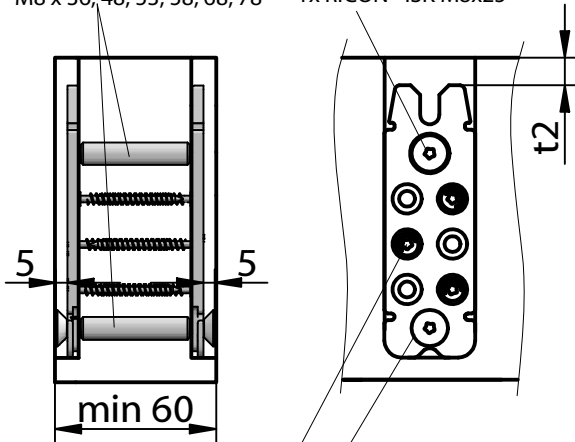

3x RICON® SK Scr 5x50
wechselseitig

1x RICON® ISK M8x25

Hauptträger- stärke [mm]	Verbund- mutterlänge [mm]
60	36
80	53

Schraubenbild im Nebenträger /
screw template for joist

2x RICON® SK Scr 8x80

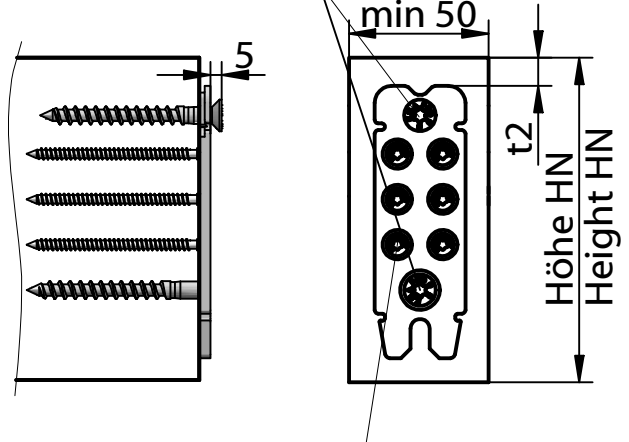

6x RICON® SK Scr 5x80

Einstellen der Schraube /
screw position adjustment

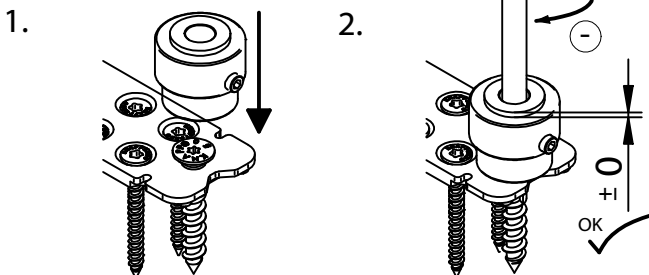

Sperrbügel einlegen /
assemble stirrup

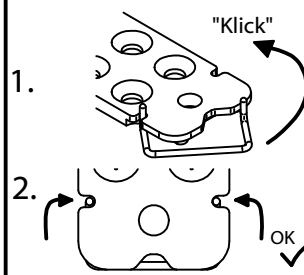

Sperrbügel lösen /
remove stirrup

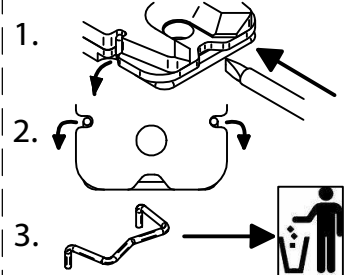

Diese Zeichnung ist Eigentum der Knapp GmbH.

© Knapp GmbH. Alle Maße in mm - Irrtümer, Druckfehler und Änderungen vorbehalten. VERSION 06.11.2013

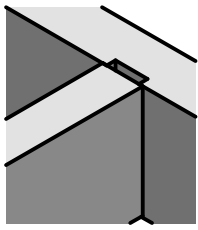

Montageanleitung/Construction Manual

RICON® 120/40 EAR

Art. Nr. K263

Einzelanschluss mit Einschraubmutter
single connection with insert screw

Haupt-Nebenträger Verbindung
main girder - joist connection

Bohrbild im Hauptträger /
 drilling template for main girder

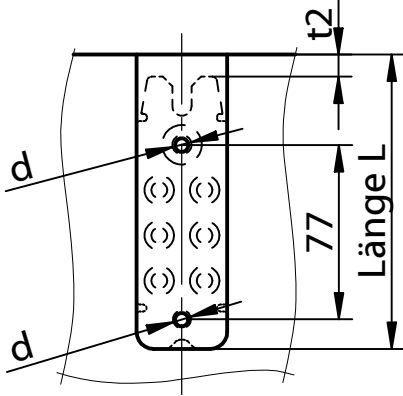

d...Ø 12 mm, 20 mm tief vorbohren
 d...Ø 12 mm, 20 mm deep predrilling

Bohrbild im Nebenträger /
 drilling template for joist

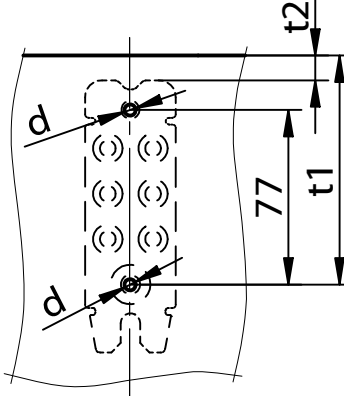

d...Ø 5mm, 30mm tief vorbohren
 d...Ø 5mm, 30mm deep predrilling

Einbohrmaße t1 und Abstandsmaß t2 in
 Abhängigkeit der Nebenträgerhöhe HN/
 Bore measure t1 and distance t2 for joist in
 reference to the height HN of the joist

Höhe / Height HN [mm]	Abstand/ Distance t1 [mm]	Abstand/ Distance t2 [mm]
140	100	10
160	110	20
180	130	40
200	140	50
220	150	60

Schraubenbild im Hauptträger /
 screw template for main girder

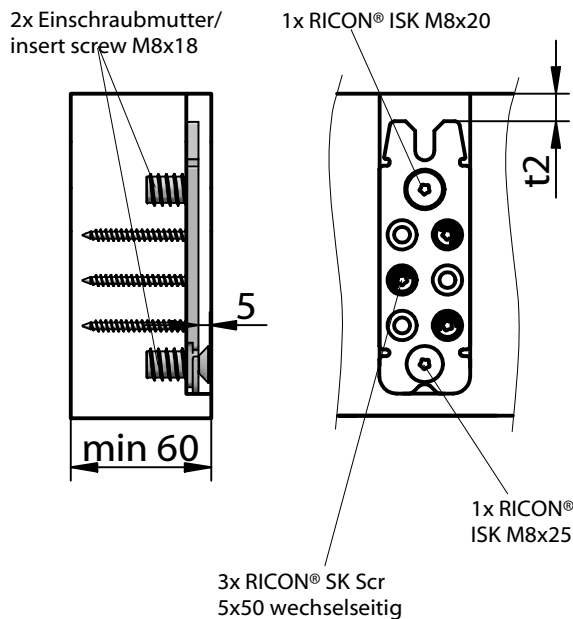

Schraubenbild im Nebenträger /
 screw template for joist

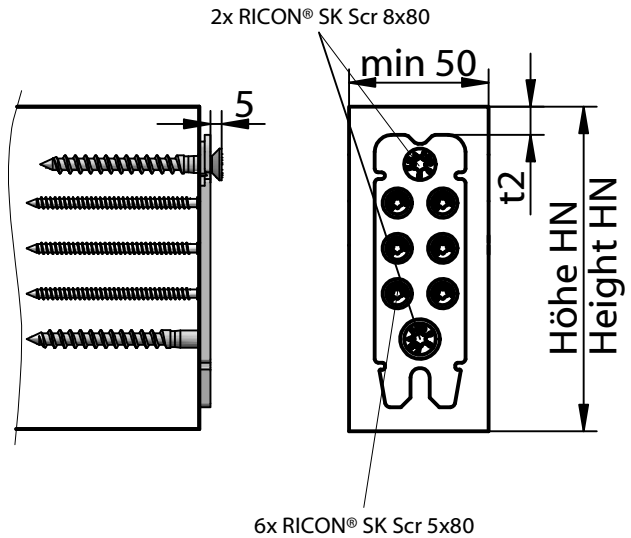

Einstellen der Schraube /
 screw position adjustment

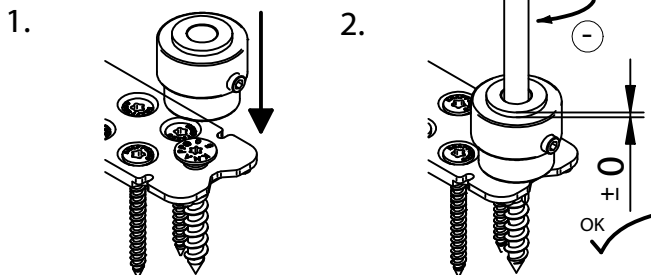

Sperrbügel einlegen /
 assemble stirrup

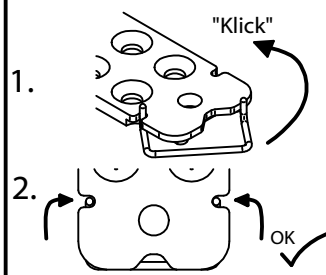

Sperrbügel lösen /
 remove stirrup

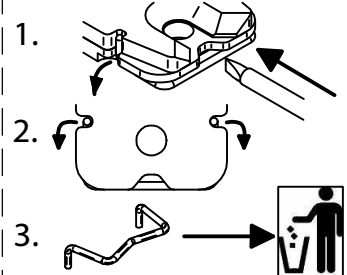

Diese Zeichnung ist Eigentum der Knapp GmbH.

© Knapp GmbH. Alle Maße in mm - Irrtümer, Druckfehler und Änderungen vorbehalten. VERSION 06.11.2013

RICON® 120/40



ETA-10/0189

Assemblage poteau - traverse

avec Avis Technique (EU + DE)

post and latch connection -

with construction supervisory approval (EU + DE)

<p>RICON® 120/40</p>	<p>Vis RICON® SK / RICON® SK Scr 8x80</p>	<p>Vis tête fraisée, empreunte 6 pans / Countersunk socket screw M8x25, M8x20</p>
	<p>Vis RICON® SK / RICON® SK Scr 8x50</p>	<p>Entretoise/ connecting nut M8x36, 48, 53, 58, 78</p>
	<p>Vis RICON® SK / RICON® SK Scr 5x80</p>	<p>Insert / insert screw M8x18</p>
	<p>Vis RICON® SK / RICON® SK Scr 5x50</p>	
	<p>Goupille de verrouillage / stirrup</p>	

Assemblage simple et doublé
Single and double connection

Assemblage poteau - traverse
Latch and post connection

Détails du fraisage traverse /
Milled edge latch

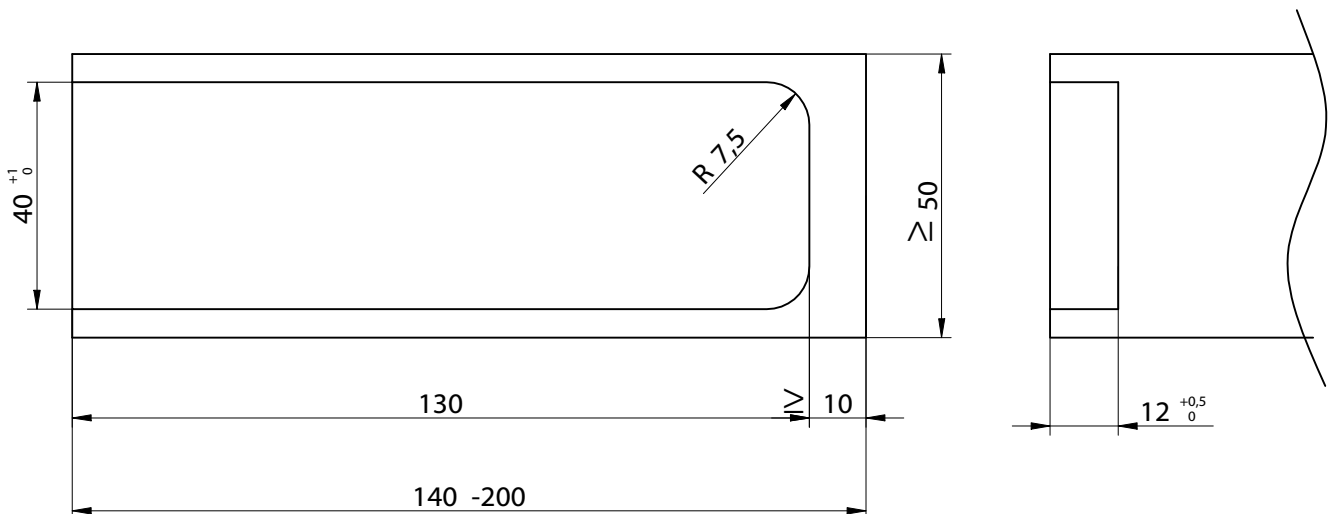

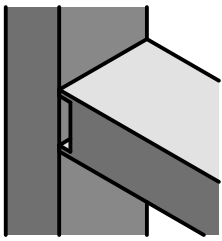

Notice de montage/Construction Manual

RICON® 120/40 EA

Assemblage simple
Single connection

Assemblage poteau - traverse
Latch and post connection

Réf. K363

Détail du perçage sur la traverse /
Drilling template for latch

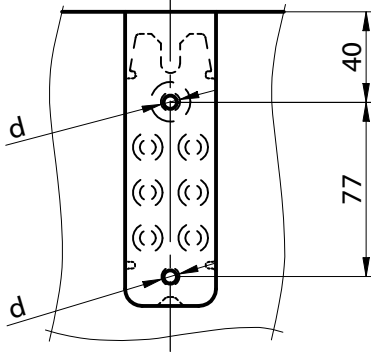

d...pré-percer Ø 5mm, prof. 30mm
d...Ø 5mm, 30mm deep predrilling

Détail du perçage sur le poteau /
Drilling template for post

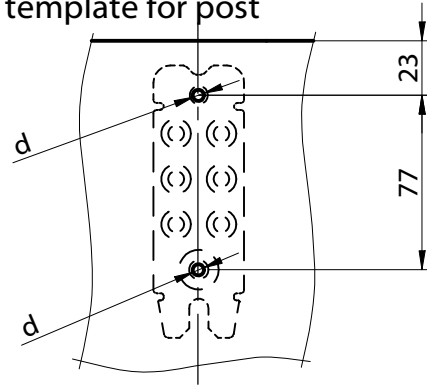

d...pré-percer Ø 5mm, prof. 30mm
d...Ø 5mm, 30mm deep predrilling

Détail du vissage sur la traverse /
screw template for latch

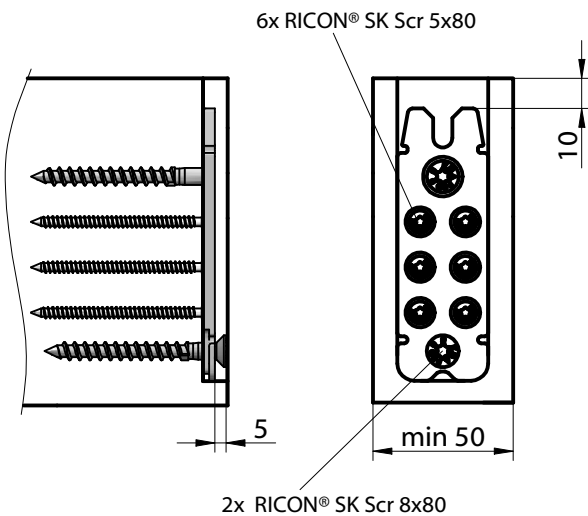

Détail du vissage sur le poteau /
Screw template for post

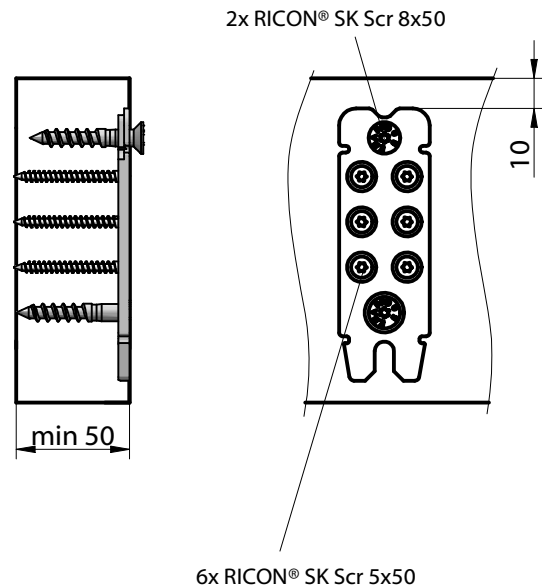

Ce dessin est la propriété de Knapp GmbH.

Régler la vis d'accroche /
Screw position adjustment

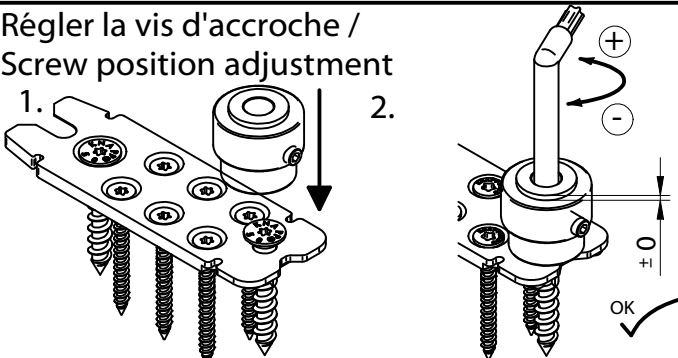

Mettre la goupille en place /
Assemble stirrup

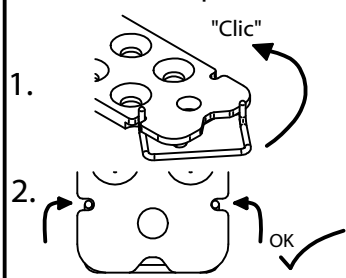

Déverrouiller la goupille /
Remove stirrup

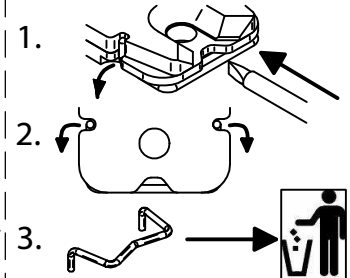

© Knapp GmbH. Toutes dimensions en mm - sauf erreurs, fautes d'impression ou modifications techniques. VERSION 06.11.2013

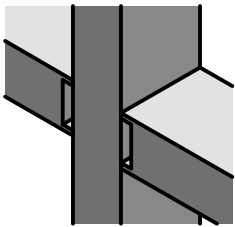

Notice de montage/Construction Manual

RICON® 120/40 DA

Réf. K163/48;
K163/58; K163/78

Assemblage doublé
Double connection

Assemblage poteau - traverse
Latch and post connection

Détail du perçage sur la traverse/
Drilling template for latch

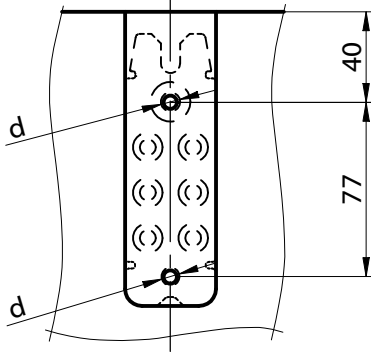

d...pré-percer Ø 5mm, prof. 30mm
d...Ø 5mm, 30mm deep predrilling

Détail du perçage sur le poteau/
Drilling template for post

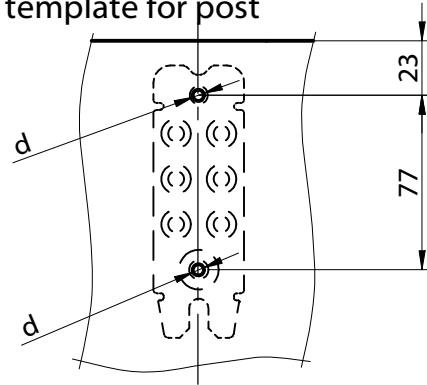

d...pré-percer en traversant Ø 10mm,
d...Ø 10mm, throughhole

Détail du vissage sur la traverse /
screw template for latch

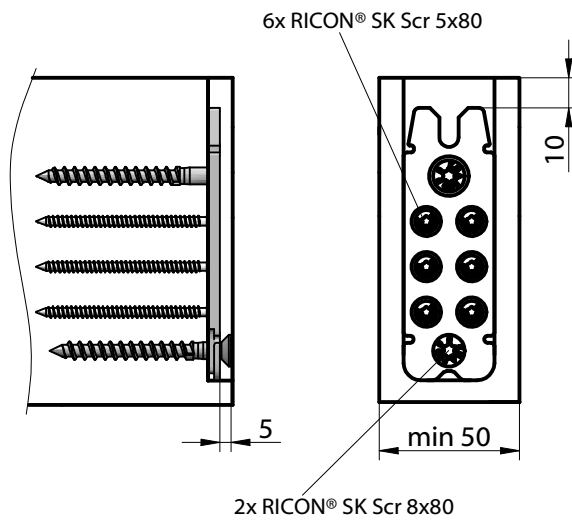

2x RICON® SK Scr 8x80

Détail du vissage sur le poteau/
Screw template for post

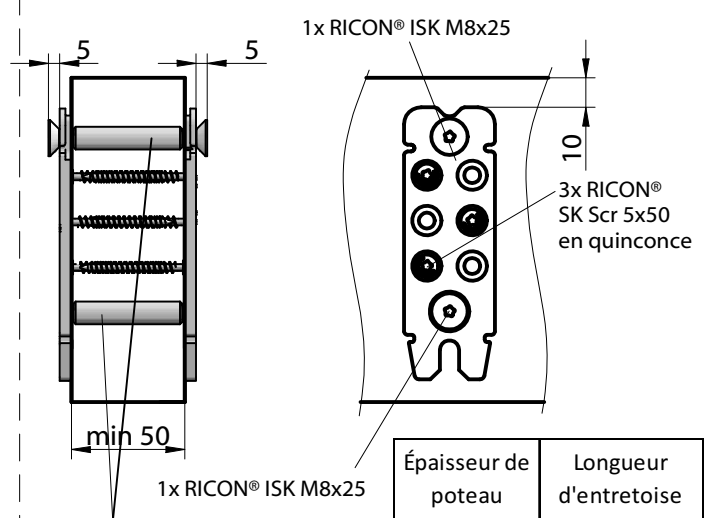

2 x Entretoises/
connecting nut
M8 x 36, 48, 53, 58
ou 78

Épaisseur de poteau [mm]	Longueur d'entretoise [mm]
50	48
56	53
60	58
80	78

Régler la vis d'accroche /
Screw position adjustment

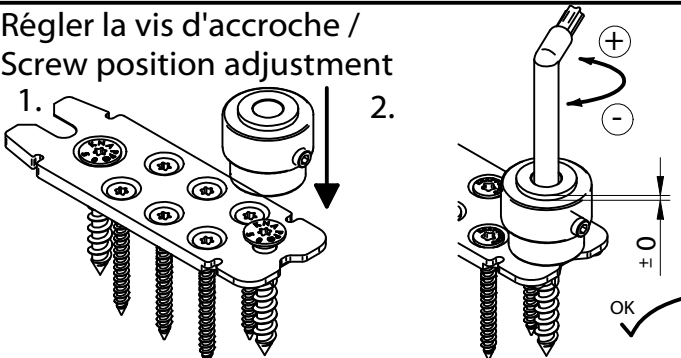

Mettre la goupille en place/
Assemble stirrup

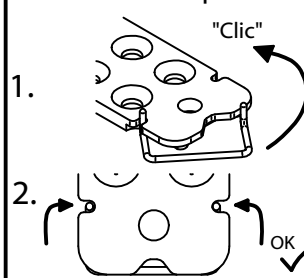

Déverrouiller la goupille /
Remove stirrup

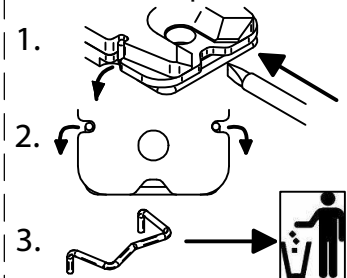

Ce dessin est la propriété de Knapp GmbH.

© Knapp GmbH. Toutes dimensions en mm - sauf erreurs, fautes d'impression ou modifications techniques. VERSION 06.11.2013

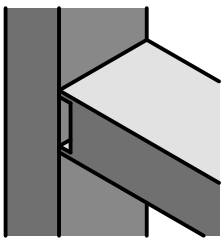

Notice de Montage/Construction Manual

RICON® 120/40 EAR

Réf. K263

Assemblage simple avec insert

Single connection with insert screw

Assemblage poteau - traverse

Latch and post connection

Détail du perçage sur la traverse /
Drilling template for latch

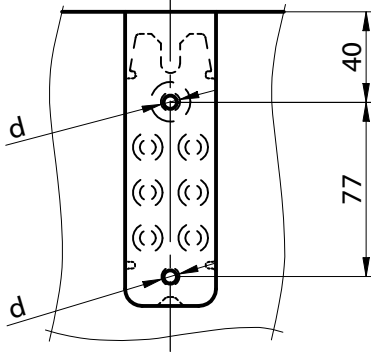

d...pré-percer Ø 5mm, prof. 30mm
d...Ø 5mm, 30mm deep predrilling

Détail du perçage sur le poteau /
Drilling template for post

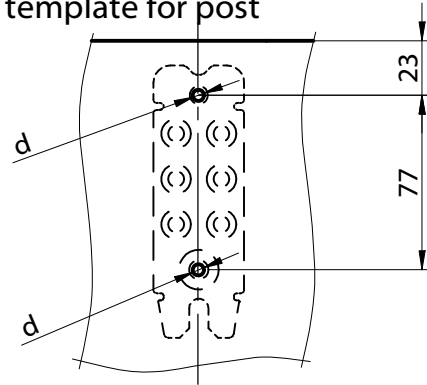

d...pré-percer Ø 12mm, prof. 20mm
d...Ø 12mm, 20mm deep predrilling

Détail du vissage sur la traverse /
screw template for latch

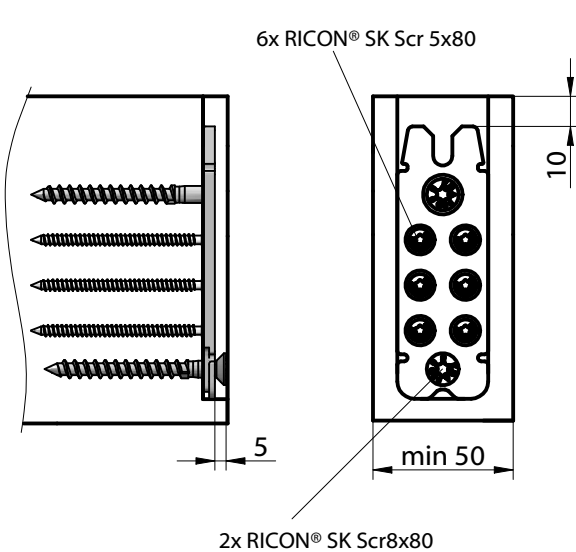

2x RICON® SK Scr 8x80

Détail du vissage sur le poteau /
Screw template for post

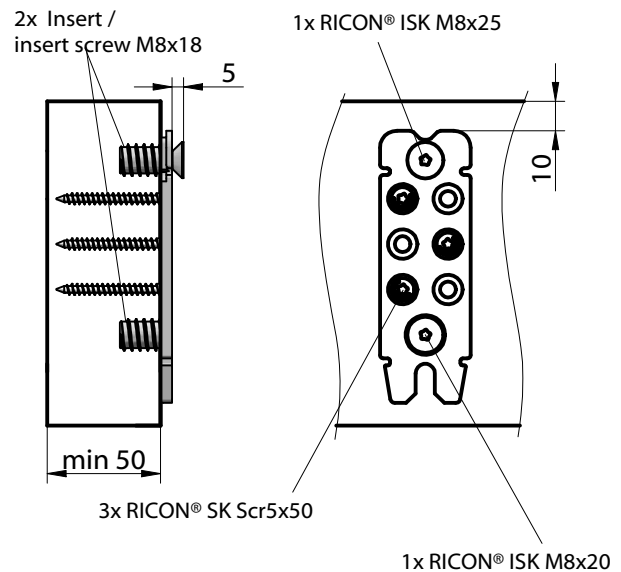

1x RICON® ISK M8x20

Ce dessin est la propriété de Knapp GmbH.

Régler la vis d'accroche /
Screw position adjustment

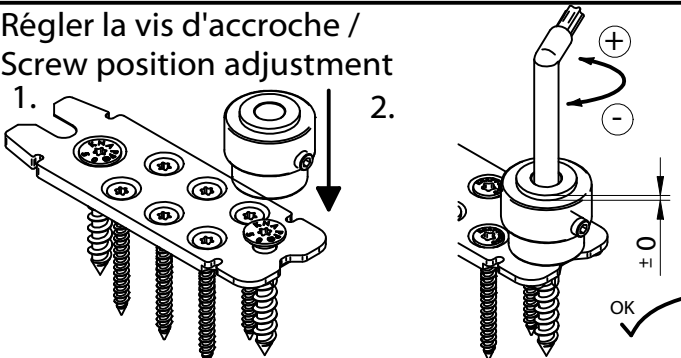

Mettre la goupille en place /
Assemble stirrup

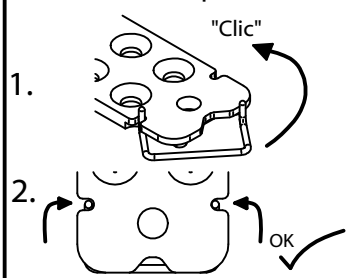

Déverrouiller la goupille /
Remove stirrup

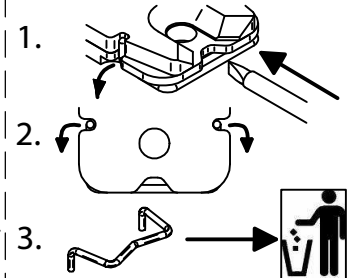

© Knapp GmbH. Toutes dimensions en mm - sauf erreurs, fautes d'impression ou modifications techniques. VERSION 06.11.2013

RICON® 120/40

Assemblage de poutre secondaire sur principale

- avec Avis Technique (EU + DE)

Main girder- joist connection

- with construction supervisory approval (EU + DE)



ETA-10/0189

RICON® 120/40

Vis RICON® SK /
RICON® SK Scr 8x80

Vis RICON® SK /
RICON® SK Scr 8x50

Vis RICON® SK /
RICON® SK Scr 5x80

Vis RICON® SK /
RICON® SK Scr 5x50

Goupille de verrouillage /
stirrup

Vis tête fraisée, emprunte 6 pans /
Countersunk socket screw
M8x25, M8x20

Entretoise/ connecting nut
M8x36, 48, 53, 58, 78

Insert / insert screw M8x18

Assemblage simple et doublé
Single and double connection

Poutre secondaire sur principale
Main girder - joist connection

Détails du fraisage poutre principale/ Milled edge main girder

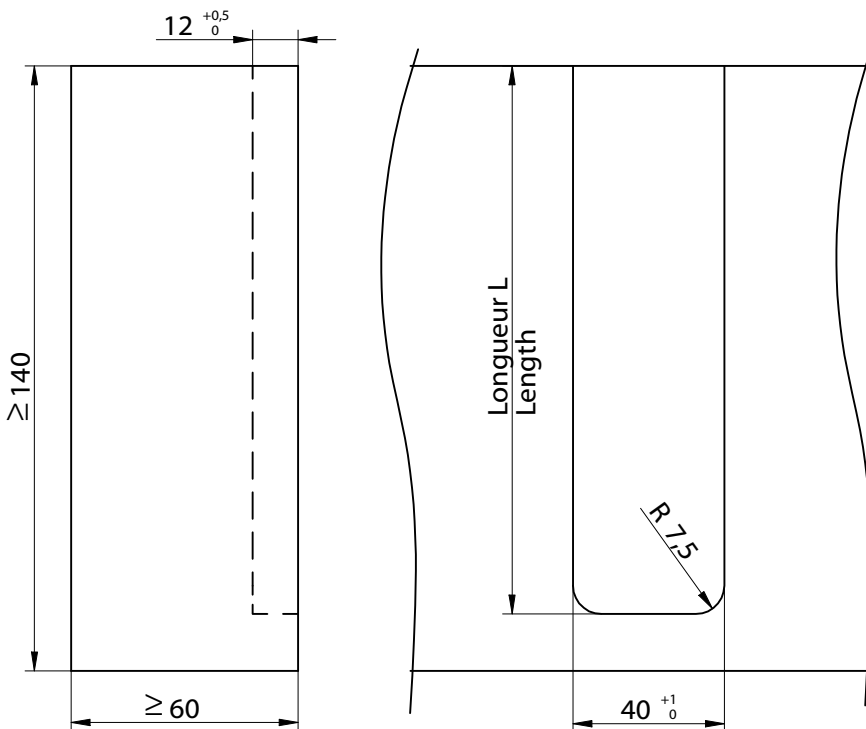

Long. de fraisage L sur pièce principale, en relation avec Ht. pièce secondaire HN /
Rebate length for main girder in reference of the height HN of the joist:

Hauteur / Height HN [mm]	Long. / Length L [mm]
140	130
160	140
180	160
200	170
220	180

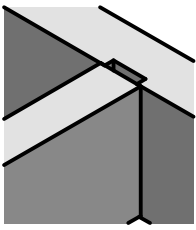

Notice de montage/Construction Manual RICON® 120/40 EA

Assemblage simple
Single connection

Poutre secondaire sur principale
Main girder - joist connection

Réf. K363

Détail du perçage sur la poutre principale / Drilling template for main girder

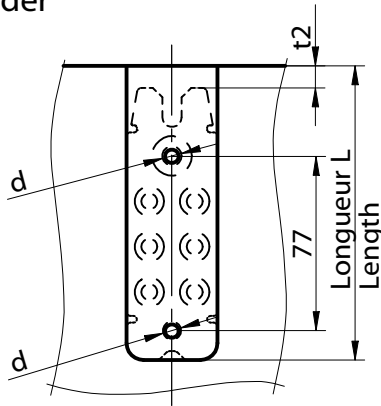

d...pré-percer Ø 5mm, prof. 30mm
d...Ø 5mm, 30mm deep predrilling

Détail du perçage sur la poutre secondaire / Drilling template for joist

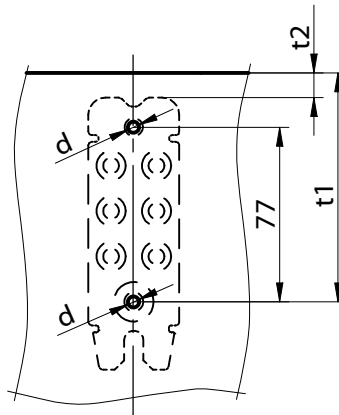

d...pré-percer Ø 5mm, prof. 30mm
d...Ø 5mm, 30mm deep predrilling

Distance de perçage t1 et t2, en relation avec la hauteur de la pièce secondaire HN / Bore measure t1 and distance t2 for joist in reference to the height HN of the joist

Hauteur / Height HN [mm]	Distance t1 [mm]	Distance t2 [mm]
140	100	10
160	110	20
180	130	40
200	140	50
220	150	60

Détail du vissage sur la poutre principale / Screw template for main girder

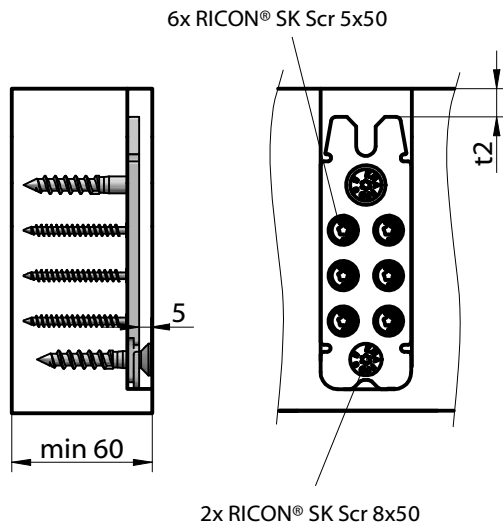

Détail du vissage sur la poutre secondaire / Screw template for joist

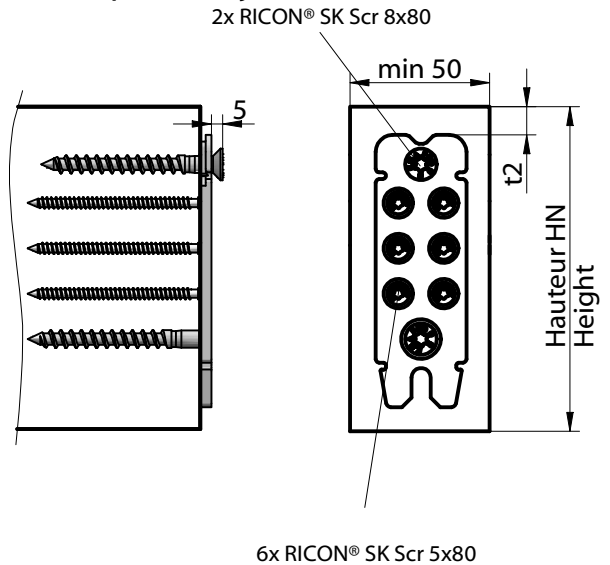

Ce dessin est la propriété de Knapp GmbH.

Régler la vis d'accroche / Screw position adjustment

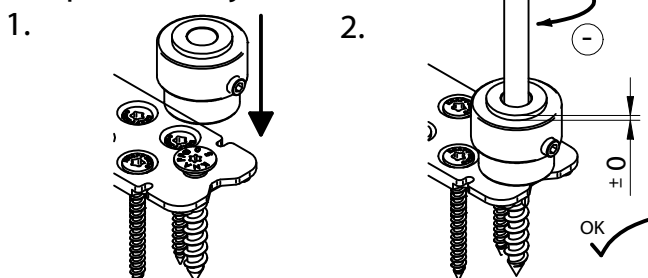

Mettre la goupille en place / Assemble stirrup

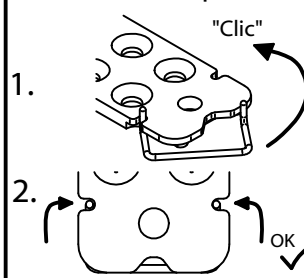

Déverrouiller la goupille / Remove stirrup

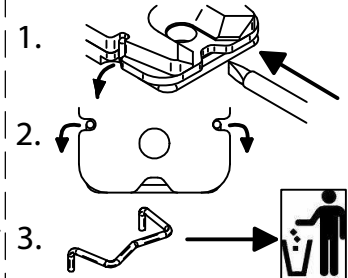

© Knapp GmbH. Toutes dimensions en mm - sauf erreurs, fautes d'impression ou modifications techniques. VERSION 06.11.2013

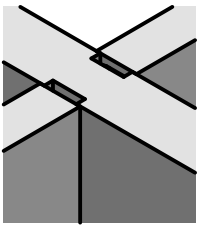

Notice de Montage/Construction Manual RICON® 120/40 DA

Réf. K163/48;
K163/58; K163/78

Assemblage doublé
Double connection

Poutre secondaire sur principale
Main girder - joist connection

Détail du perçage sur la poutre principale / Drilling template for main girder

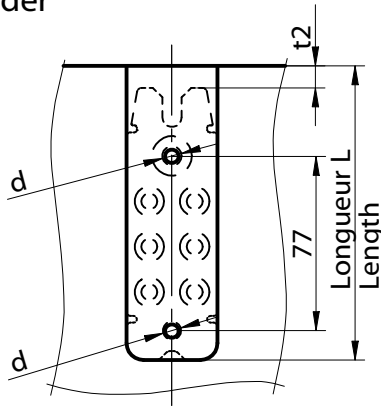

Détail du perçage sur la poutre secondaire / Drilling template for joist

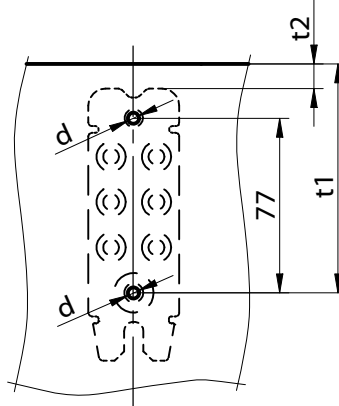

Distance de perçage t1 et t2, en relation avec la hauteur de la pièce secondaire HN / Bore measure t1 and distance t2 for joist in reference to the height HN of the joist

Hauteur / Height HN [mm]	Distance t1 [mm]	Distance t2 [mm]
140	100	10
160	110	20
180	130	40
200	140	50
220	150	60

d...pré-percer en traversant Ø 10mm, d...Ø 10mm, throughhole

d...pré-percer Ø 5mm, prof. 30mm d...Ø 5mm, 30mm deep predrilling

Détail du vissage sur la poutre principale / Screw template for main girder

2x entretoises / connecting nut M8 x 36, 48, 53, 58 ou 78

1x RICON® ISK M8x25

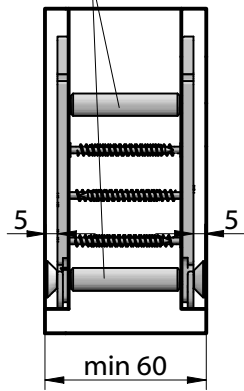

3x RICON SK Scr 5x50 en quinconce

Ép. de pièce principale [mm]	Longueur d'entretoise [mm]
60	36
80	53

Détail du vissage sur la poutre secondaire / Screw template for joist

2x RICON® SK Scr 8x80

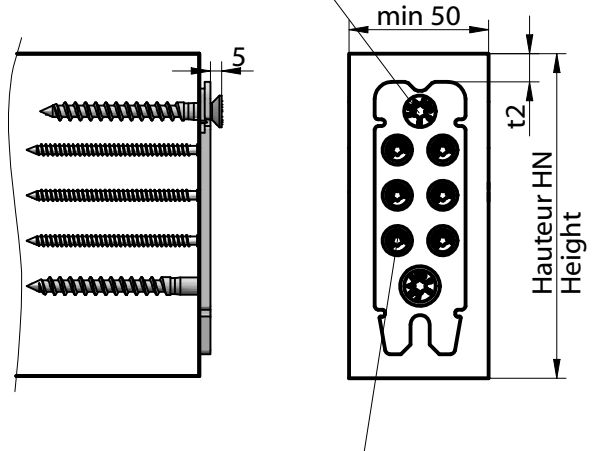

6x RICON® SK Scr 5x80

Ce dessin est la propriété de Knapp GmbH.

Régler la vis d'accroche / Screw position adjustment

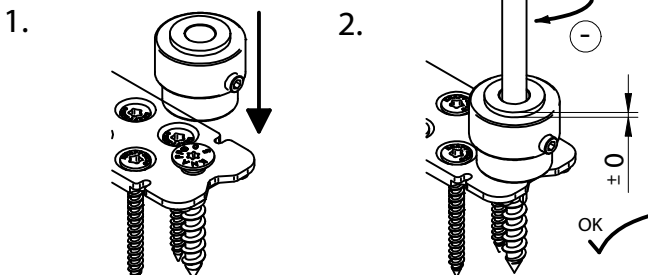

Mettre la goupille en place / Assemble stirrup

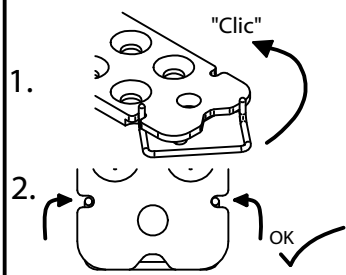

Déverrouiller la goupille / Remove stirrup

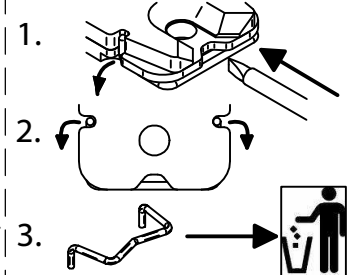

© Knapp GmbH. Toutes dimensions en mm - sauf erreurs, fautes d'impression ou modifications techniques. VERSION 06.11.2013

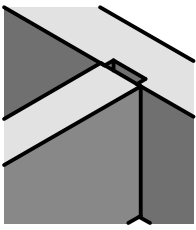

Notice de Montage/Construction Manual RICON® 120/40 EAR

Assemblage simple avec insert Poutre secondaire sur principale
Single connection with insert screw Main girder - joist connection

Réf. K263

Détail du perçage sur la poutre principale / Drilling template for main girder

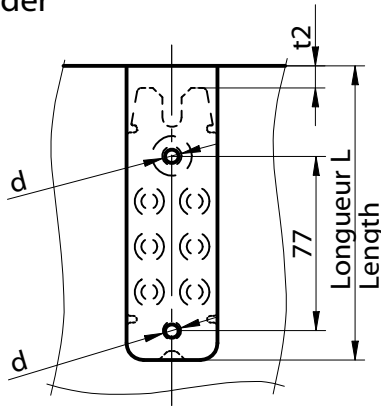

d...pré-percer Ø 12mm, prof. 20 mm
d...Ø 12mm, 20 mm deep predrilling

Détail du perçage sur la poutre secondaire / Drilling template for joist

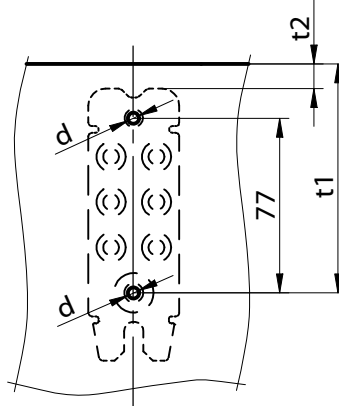

d...pré-percer Ø 5mm, prof. 30mm
d...Ø 5mm, 30mm deep predrilling

Distance de perçage t1 et t2, en relation avec la hauteur de la pièce secondaire HN / Bore measure t1 and distance t2 for joist in reference to the height HN of the joist

Hauteur / Height HN [mm]	Distance t1 [mm]	Distance t2 [mm]
140	100	10
160	110	20
180	130	40
200	140	50
220	150	60

Détail du vissage sur la poutre principale / Screw template for main girder

2x Insert / insert screw M8x18

1x RICON® ISK M8x20

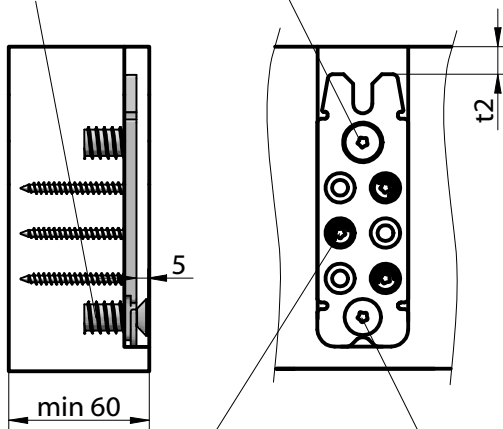

3x RICON® SK Scr 5x50 en quinconce

1x RICON® ISK M8x25

Détail du vissage sur la poutre secondaire / Screw template for joist

2x RICON® SK Scr 8x80

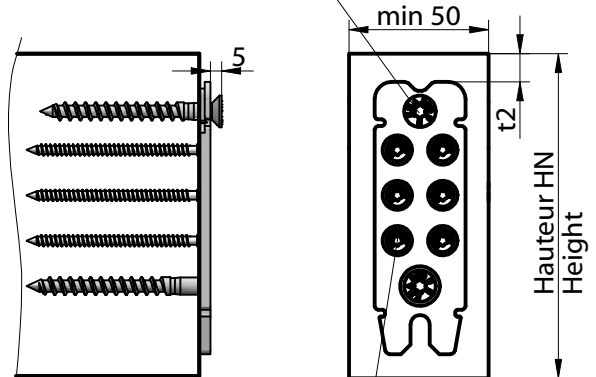

6x RICON® SK Scr 5x80

Régler la vis d'accroche / Screw position adjustment

1. 2.

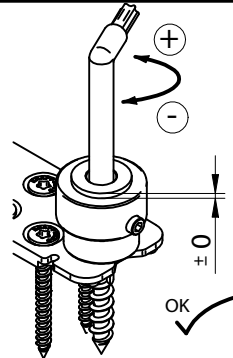
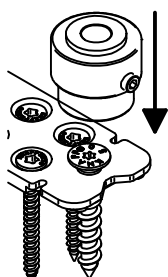

Mettre la goupille en place / Assemble stirrup

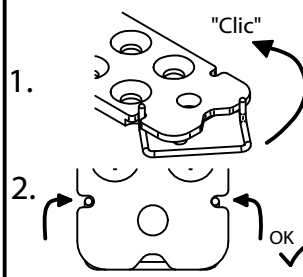

Déverrouiller la goupille / Remove stirrup

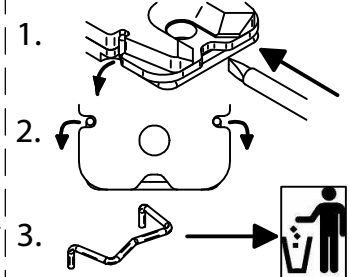

Ce dessin est la propriété de Knapp GmbH.

© Knapp GmbH. Toutes dimensions en mm - sauf erreurs, fautes d'impression ou modifications techniques. VERSION 06.11.2013